



Traffic Study

Weston Town Center
Weston, Connecticut
October 10, 2019

Prepared for:
Mr. Jonathan Luiz
Weston Town Administrator
Town of Weston
56 Norfield Road
Weston, Connecticut 06883

MMI #1811-16-01

Prepared by:
MILONE & MACBROOM, INC.
195 Church Street, 7th Floor
New Haven, Connecticut 06510
(203) 344-7887
www.mminc.com



MILONE & MACBROOM

ENGINEERING | PLANNING | LANDSCAPE ARCHITECTURE | ENVIRONMENTAL SCIENCE

TABLE OF CONTENTS

PROJECT UNDERSTANDING.....1

EXISTING CONDITIONS.....1

 Crash History.....2

 TABLE 1 Crash Summary.....2

 Peak Hour Traffic Volumes2

 Existing Traffic Flow Operations.....3

 TABLE 2 Capacity Analysis Summary Existing Conditions.....3

PREFERRED CONCEPT TRAFFIC4

 Trip Generation.....4

 Trip Distribution4

 TABLE 3 Trip Generation Estimate5

HORIZON YEAR (2049) CONDITIONS6

 Peak Hour Traffic Volumes6

 Traffic Flow Operations.....6

 TABLE 4 Capacity Analysis Summary Horizon Year (2049) Plus Preferred Project Conditions.....7

ADDITIONAL INTERSECTION IMPROVEMENTS8

 TABLE 5 Capacity Analysis Summary – Additional Intersection Improvements8

SUMMARY AND CONCLUSIONS.....9

ATTACHMENTS AND APPENDICIES 10

October 10, 2019

Mr. Jonathan Luiz
Weston Town Administrator
Town of Weston
56 Norfield Road
Weston, CT 06883

**RE: Traffic Evaluation
Town Center Master Plan
Town of Weston
MMI #1811-16-01**

Dear Mr. Luiz:

At your request, we have undertaken this assignment to assess the traffic implications of the Weston Town Center Master Plan along Weston Road (CT-57) between School Road and Norfield Road (CT-53).

PROJECT UNDERSTANDING

The Weston Town Center Master Plan was completed in July 2019. It is a road map that the Town of Weston can follow to achieve the community's collective vision for a Town Center.

The plan includes a Preferred Concept for enhancing the Town Center. The Weston Town Center Preferred Concept is considered the project for this traffic evaluation ("Preferred Concept"). **Figure 1** displays the Preferred Concept as presented in the Weston Town Center Master Plan (June 24, 2019). As shown in the Figure, the Preferred Concept includes expanded community services and commercial developments as well as additional green spaces and improved pedestrian facilities. The Preferred Concept is aspirational in nature and depicts the overall vision for the Weston Town Center. It is important to keep in mind that actual development will not look exactly like what is depicted in the Master Plan and development will happen over a long period of time.

To fully assess the traffic implications of the Weston Town Center Preferred Concept, a 30-year horizon (Year 2049) was evaluated. It is assumed that all Weston Town Center Master Plan recommendations will be in place under the Horizon Year scenario. The evaluation will provide an estimate of the traffic operations of a fully-built Weston Town Center and will be used to assess the adequacy of the Local Transportation Capital Improvement Program (LOTICIP) Project at the intersection of Norfield Road (CT-57) at School Road and to recommend additional intersection improvements.

EXISTING CONDITIONS

The existing information involving the crash history, vehicle volumes, and pedestrian volumes was collected to determine the existing conditions of Weston Road (CT-57).

Crash History

Information on traffic crash statistics for Weston Road (CT-57) was obtained from the University of Connecticut's Connecticut Crash Data Repository for the period of January 1, 2016, to October 2, 2019. The crash data collected for this period is shown in **Table 1**, summarized by location and collision type.

TABLE 1
Crash Summary

LOCATION:	CRASH SEVERITY			TYPE OF COLLISION								
	INJURY	PROPERTY DAMAGE ONLY	TOTAL	ANGLE	BACKING	FIXED-OBJECT	HEAD-ON	REAR-END	SIDESWIPE, OPPOSITE DIRECTION	SIDESWIPE, SAME DIRECTION	UNKNOWN	TOTAL
Intersection 1 – Weston Road (CT-57) at Norfield Road (CT-53)	7	18	25	5	1	1	1	14	1	1	1	25
Intersection 2 – Weston Road (CT-57) at School Road	3	8	11	0	0	3	0	7	1	0	0	11
Weston Road (CT-57) between Norfield Road (CT-53) and School Road	2	10	12	2	1	0	0	3	1	3	2	12
Norfield Road (CT-53) west of Weston Road (CT-57)	0	0	0	0	0	0	0	0	0	0	0	0
Norfield Road (CT-53) east of Weston Road (CT-57)	1	1	2	0	0	0	0	2	0	0	0	2
Total	13	37	50	7	2	4	1	26	3	4	3	50

Source: University of Connecticut's Connecticut Crash Data Repository from January 1, 2016, to October 2, 2019

A total of 50 crashes were reported for the nearly 3-year period on Weston Road (CT-57) between School Road and Norfield Road (CT-53), 37 of which were property damage only and 13 were possible injuries. Most crashes were rear-end collisions that occurred at the intersection Weston Road (CT-57) and Norfield Road (CT-53). The intersection of Weston Road (CT-57) and School Road had seven reported rear-end collisions, 11 collisions in total.

Peak Hour Traffic Volumes

Manual turning movement counts for pedestrians and vehicles were performed at the intersections of Weston Road (CT-57) at Norfield Road (CT-53) and Weston Road (CT-57) at School Road. The counts were performed on Thursday, September 5, 2019, from 7:00 a.m. to 9:00 a.m. and 4:00 p.m. to 6:00 p.m. during

typical peak periods. The existing baseline peak-hour traffic volumes were determined from the turning movement counts and are shown in **Figure 2**. Count data is included in the Appendix.

Existing Traffic Flow Operations

The study intersections were evaluated by means of capacity analysis techniques using *Synchro* traffic analysis software package. Using *Synchro 10* (Trafficware), the Levels of Service (LOS) were determined. LOS is used to provide a qualitative evaluation of the efficiency of operations of an intersection in terms of delay and inconvenience based on certain quantitative calculations. A description of the various LOS designations, A through F, is given in the Appendix. LOS A describes operations with very low average control delay per vehicle while LOS F describes operations with long average delays.

Table 2 summarizes the findings of the Existing Conditions LOS analysis results for the study intersections. The *Synchro* analysis worksheets are included in the Appendix. In general, all movements currently operate at acceptable conditions (LOS A to LOS D) with the exception of the eastbound approach at the intersection of Weston Road (CT-57) and Norfield Road (CT-53).

The eastbound approach LOS can be improved with timing changes to the traffic signal. A separate analysis was conducted with signal timing changes for the evening peak hour. The improved LOS is shown in Table 2 in parenthesis "()". However, the capacity and LOS during the evening peak hour is of concern under Existing Conditions.

**TABLE 2
 Capacity Analysis Summary
 Existing Conditions**

Intersection	Level of Service (LOS)	
	Morning Peak Hour	Evening Peak Hour
Signalized		
1. Weston Road (CT-57) at Norfield Road (CT-53)		
Eastbound Left/Through/Right	C	F (D)
Westbound Left/Through	D	C (C)
Westbound Right	A	A (A)
Northbound Left/Through/Right	D	D (D)
Southbound Left/Through/Right	B	B (C)
2. Weston Road (CT-57) at School Road		
Westbound Left	D	D
Westbound Right	B	B
Northbound Through/Right	B	C
Southbound Left/Through	A	A

Notes:
Bold values indicate intersections operating at LOS E-F (unacceptable conditions).
 "()" is the LOS with improved signal timing changes
 LOS calculations are based on the methodology outlined in the *Highway Capacity Manual*, 6th Edition and performed using *Synchro 10*.

PREFERRED CONCEPT TRAFFIC

As stated previously, the Weston Town Center Preferred Concept is considered the project for this traffic evaluation. **Figure 3** displays the components of the project based on the Weston Town Center Master Plan Preferred Concept. For the purpose of this analysis, the Town Center was divided into 6 sections (Development Areas A-F) based on the proposed access points. Three new intersections (Intersections 3 – 5) are assumed to be constructed with the development of the Preferred Concept to provide access to the development sites.

Trip Generation

It is assumed that all development proposed in the Preferred Concept will be completed in 30 years (Horizon Year). The Preferred Concept traffic was estimated based on review of statistical data published by the Institute of Transportation Engineers (ITE)¹.

It is important to note, the Preferred Concept depicts the overall vision for the Weston Town Center, but is not very specific in detail. Assumptions regarding the breakdown of square footages and land-use designations were made. A net trip generation was established for each development area. The resulting site trip generation is displayed in **Table 3**.

The total net trip generation represent the total number of new trips that will be coming to Weston Town Center. For Development Area B (Weston Center), the existing land uses were subtracted from the proposed land uses to determine the net trip generation. At the time of this analysis, the disposition of the bus depot is unknown, and the existing land uses in Development Areas C, D, E, and F are minor traffic generators. Existing traffic from those uses were therefore not deducted from the analysis. In addition, no credit for pass by, nor credit for potential trips replaced by walking, nor credit for internal capture was taken in this analysis. Given these factors, the analysis of potential traffic impacts described below should be noted to be conservative.

As shown in Table 3, once completed, the Preferred Concept is expected to generate approximately 163 total new vehicle trips (96 vehicles entering and 67 vehicles exiting) during the morning peak hour and 272 total vehicle trips (43 vehicles entering and 46 vehicles exiting) during the afternoon peak hour.

Trip Distribution

The estimated directional distribution for the site traffic was based on review of area travel patterns. It is estimated that approximately 30 percent of the traffic will be coming from the north and 30 percent from the south along Weston Road (CT-57). Approximately 20 percent of the traffic will be coming from the east and 20 percent from the west along Norfield Road (CT-53). **Figure 4** illustrates the general distribution for the newly generated Weston Town Center Preferred Concept traffic. **Figure 5** illustrates the assignment of the anticipated traffic volumes based on the distribution during the weekday morning and afternoon peak hours. The individual distributions and traffic volumes for each development area is included in the Appendix.

¹ *Trip Generation*, 10th Edition, Institute of Transportation Engineers

TABLE 3
Trip Generation Estimate

Land Use	Units	Morning Peak Hour			Evening Peak Hour				
		Trip Rate	In	Out	Total	Trip Rate	In	Out	Total
Development Area A									
<i>Proposed</i>									
495 – Recreational Community Center	5 ksf	1.76/ksf	6	3	9	2.31/ksf	5	7	12
Net Trip Generation			6	3	9		5	7	12
Development Area B									
<i>Proposed</i>									
820 – Shopping Center	23 ksf	0.94/ksf	13	9	22	3.81/ksf	42	46	88
932 – High-Turnover (Sit-Down) Restaurant	3 ksf	9.94/ksf	16	14	30	9.77/ksf	18	11	29
712 – Small Office Building	12.5 ksf	1.92/ksf	20	4	24	2.45/ksf	10	21	31
220 – Multi-family Housing (Low-Rise)	9 ksf	0.46/ksf	1	3	4	0.56/ksf	3	2	5
Proposed Total			50	30	80		73	80	153
<i>Existing</i>									
820 – Shopping Center	24.9 ksf	0.94/ksf	15	8	23	3.81/ksf	46	49	95
Existing Total			15	8	23		46	49	95
Net Trip Generation			35	22	57		27	31	58
Development Area C									
<i>Proposed</i>									
820 – Shopping Center	2 ksf	0.94/ksf	1	1	2	3.81/ksf	4	4	8
931 – Quality Restaurant	3 ksf	0.73/ksf	1	1	2	7.8/ksf	16	7	23
712 – Small Office Building	1.5 ksf	1.92/ksf	2	1	3	2.45/ksf	1	3	4
220 – Multi-family Housing (Low-Rise)	3 ksf	0.46/ksf	0	1	1	0.56/ksf	1	1	2
Net Trip Generation			4	4	8		22	15	37
Development Area D									
<i>Proposed</i>									
820 – Shopping Center	3	0.94/ksf	2	1	3	3.81/ksf	5	6	11
932 – High-Turnover (Sit-Down) Restaurant	3	9.94/ksf	16	14	30	9.77/ksf	18	11	29
712 – Small Office Building	1.3	1.92/ksf	2	0	2	2.45/ksf	1	2	3
220 – Multi-family Housing (Low-Rise)	3	0.46/ksf	0	1	1	0.56/ksf	1	1	2
Net Trip Generation			20	16	36		25	20	45
Development Area E									
<i>Proposed</i>									
820 – Shopping Center	11 ksf	0.94/ksf	6	4	10	3.81/ksf	20	22	42
931 – Quality Restaurant	3 ksf	0.73/ksf	1	1	2	7.8/ksf	16	7	23
Net Trip Generation			7	5	12		36	29	65
Development Area F									
<i>Proposed</i>									
820 – Shopping Center	4.5 ksf	0.94/ksf	3	1	4	3.81/ksf	8	9	17
932 – High-Turnover (Sit-Down) Restaurant	3 ksf	9.94/ksf	16	14	30	9.77/ksf	18	11	29
712 – Small Office Building	3 ksf	1.92/ksf	5	1	6	2.45/ksf	2	5	7
220 – Multi-family Housing (Low-Rise)	3 ksf	0.46/ksf	0	1	1	0.56/ksf	1	1	2
Net Trip Generation			24	17	41		29	26	55
TOTAL NET TRIP GENERATION			96	67	163		144	128	272

Notes:

1. Ksf = Thousand square feet
2. Trip Generation, 10th Edition, Institute of Transportation Engineers

HORIZON YEAR (2049) CONDITIONS

Horizon Year (2049) Conditions were evaluated to assess the traffic operations of a fully built Weston Town Center. It is assumed that new driveways will be constructed with the development of the Preferred Concept (Intersections 3 through 5). It is also assumed that crosswalks will be constructed at all approaches at the intersections of Weston Road (CT-57) at Norfield Road (CT-53) and Weston Road (CT-57) at School Road.

Additionally, Weston was awarded grant funding from the Local Transportation Capital Improvement Program (LOTICIP). The grant funding includes intersection and safety improvements at the intersection of Weston Road (CT-57) and School Road. It includes the construction of the northbound right-turn lane and a southbound left-turn lane. It is assumed that these improvements will be constructed before Horizon Year (2049). The proposed improvements are included in the Appendix.

Figure 6 displays the assumed intersection geometry under Horizon Year (2049) Conditions.

Peak Hour Traffic Volumes

Peak-hour intersection turning movement volumes under Horizon Year (2049) Conditions without the addition of the Weston Town Center Preferred Concept (no build) were received from the Connecticut Department of Transportation Bureau of Policy and Planning. These volumes are included in the Appendix.

Peak-hour intersection turning movement volumes under Horizon Year (2049) Conditions with the addition of the Weston Town Center Preferred Concept were determined by adding the estimated new traffic to the Horizon Year (2049) no-build peak-hour traffic volumes. These volumes are shown in **Figure 7**.

Traffic Flow Operations

The study intersections were evaluated under Horizon Year (2049) Conditions by means of capacity analysis techniques. **Table 4** summarizes the findings of the LOS analysis results for the study intersections with the estimated new traffic generated by the Weston Town Center Preferred Concept. The *Synchro* analysis worksheets are included in the Appendix.

The intersection of Weston Road (CT-57) and Norfield Road (CT-53) is expected to operate at unacceptable conditions (LOS E and LOS F) under Horizon Year (2049) Plus Preferred Concept Conditions. The intersection operates at a LOS F in the eastbound approach under Existing Conditions and is expected to get worse in the future.

The intersection of Weston Road (CT-57) and School Road is expected to operate at acceptable conditions (LOS A to LOS C) with the funded transportation projects under Horizon Year (2049) Plus Preferred Concept Conditions. All development area driveways are expected to operate at acceptable conditions under Horizon Year (2049) Plus Preferred Concept Conditions.

TABLE 4
Capacity Analysis Summary
Horizon Year (2049) Plus Preferred Concept Conditions

Intersection	Level of Service (LOS)	
	Morning Peak Hour	Evening Peak Hour
Signalized		
1. Weston Road (CT-57) at Norfield Road (CT-53)		
Eastbound Left/Through/Right	F	F
Westbound Left/Through	F	D
Westbound Right	C	A
Northbound Left/Through/Right	F	F
Southbound Left/Through/Right	C	F
2. Weston Road (CT-57) at School Road		
Westbound Left	C	C
Westbound Right	A	A
Northbound Through	B	C
Northbound Right	A	A
Southbound Left	A	A
Southbound Through	A	A
Unsignalized		
3. Weston Road (CT-57) at Weston Center (Development Areas B and D)		
Eastbound Left/Through/Right	D	D
Westbound Left/Through/Right	D	D
4. Norfield Road (CT-53) at Development Areas C and E		
Northbound Left/Through/Right	B	C
Southbound Left/Through/Right	C	C
5. Norfield Road (CT-53) at Development Areas D and F		
Northbound Left/Through/Right	C	C
Southbound Left/Through/Right	B	B

Notes:

Bold values indicate intersections operating at LOS E-F (unacceptable conditions).
 LOS calculations are based on the methodology outlined in the *Highway Capacity Manual*, 6th Edition and performed using *Synchro 10*.

ADDITIONAL INTERSECTION IMPROVEMENTS

To return all movements at the intersection of Weston Road (CT-57) and Norfield Road (CT-53) to operate at acceptable conditions under Horizon Year (2049) Conditions, it is recommended to provide one left-turn lane and one right/through lane at each approach. The westbound, northbound, and southbound approaches are all currently over 36 feet wide and would most likely only require restriping to provide the recommended improvements. The eastbound approach would most likely require widening to provide the left-turn lane and right/through lane. **Figure 8** displays the recommended intersection improvements at Weston Road (CT-57) and Norfield Road (CT-53).

The intersection was evaluated with the recommended improvements under Horizon Year (2049) Plus Preferred Concept Conditions by means of capacity analysis techniques. A separate analysis was also completed including the restriping of the westbound, northbound, and southbound approaches but not including the widening of the eastbound approach (the eastbound approach would remain as is). **Table 5** summarizes the findings of the LOS analysis results. The *Synchro* analysis worksheets are included in the Appendix.

TABLE 5
Capacity Analysis Summary – Additional Intersection Improvements
Horizon Year (2049) Plus Preferred Concept Conditions

LOS					
Restripe the Westbound, Northbound, and Southbound Approaches			Restripe the Westbound, Northbound, and Southbound Approaches AND Widen the Eastbound Approach		
Intersection Movement	Morning Peak Hour	Evening Peak Hour	Intersection Movement	Morning Peak Hour	Evening Peak Hour
1. Weston Road (CT-57) at Norfield Road (CT-53)					
Eastbound Left/Through/Right	C	E	Eastbound Left	D	B
Westbound Left	B	A	Eastbound Through/Right	A	C
Westbound Through/Right	C	A	Westbound Left	B	B
Northbound Left	D	C	Westbound Through/Right	C	A
Northbound Through/Right	B	D	Northbound Left	D	B
Southbound Left	B	E	Northbound Through/Right	B	B
Southbound Through/Right	C	C	Southbound Left	A	C
			Southbound Through/Right	C	B

Notes:

Bold values indicate intersections operating at LOS E-F (unacceptable conditions).

LOS calculations are based on the methodology outlined in the *Highway Capacity Manual*, 6th Edition and performed using *Synchro 10*.

As shown in the table, all movements are expected to operate at a LOS D or better with the recommended intersection improvements. Restriping the westbound, northbound, and southbound approaches but leaving the eastbound approach as is would improve operations, however, the eastbound approach and the southbound left-turn movement are expected to operate at a LOS E during the evening peak hour. It is important to note that these additional intersection improvements are based on Horizon Year (2049) analysis.

SUMMARY AND CONCLUSIONS

An evaluation of the proposed traffic conditions for the Weston Town Center Preferred Concept was undertaken through a detailed field reconnaissance and data assembly effort. Based on our analysis, once completed, the Preferred Concept is not expected to have a significant traffic impact on the surrounding roadway system within the next 30 years except for the intersection of Weston Road (CT-57) and Norfield Road (CT-53).

This intersection operates at a LOS F at the eastbound approach during the evening peak hour under Existing Conditions and is expected to get worse during both peak hours under Horizon Year (2049) Plus Preferred Concept Conditions. To return all movements at the intersection to operate at acceptable conditions (LOS A to LOS D), it is recommended to provide one left-turn lane and one right/through lane at each approach. These improvements will likely only require widening at the eastbound approach. All other approaches are likely wide enough to provide the recommended improvements with restriping. With this recommendation, all movements are expected to operate at a LOS D or better under Horizon Year (2049) Plus Preferred Concept Conditions.

Additionally, all movements at the intersection of Weston Road (CT-57) and School Road are expected to operate at a LOS C or better with the funded transportation projects under Horizon Year (2049) Plus Preferred Concept Conditions.

We hope this assessment is useful to you in evaluating the traffic impacts from the Weston Town Center Preferred Concept. If you have any questions or need any further information, please do not hesitate to contact us.

Very truly yours,

MILONE & MACBROOM, INC.



David G. Sullivan, PE, Associate
Manager of Traffic & Transportation Planning



Emily A. Foster, PE
Project Engineer, Transportation

Attachments

1811-16-01-o919-rpt

Attachments:

- Figure 1 – Weston Town Center Master Plan Preferred Concept
- Figure 2 – Existing Peak Hour Volumes
- Figure 3 – Weston Town Center Preferred Concept Land Use Assumptions
- Figure 4 – Weston Town Center Preferred Concept Distribution
- Figure 5 - Weston Town Center Preferred Concept Peak Hour Volumes
- Figure 6 – Horizon Year (2049) Intersection Geometrics (Includes Funded Improvements)
- Figure 7 - Horizon Year (2049) Plus Preferred Concept Peak Hour Volumes
- Figure 8 – Additional Intersection Improvements at Weston Road and Norfield Road

Appendices:

- Existing Count Data
- LOS Descriptions
- Existing Conditions *Synchro* Worksheets
- Development Areas Trip Distribution
- Horizon Year (2049) No Build Conditions Peak Hour Volumes
- Funded Transportation Projects at Weston Road (CT-57) and School Road
- Horizon Year (2049) Plus Preferred Concept Conditions *Synchro* Worksheets
- Horizon Year (2049) Plus Preferred Concept Conditions with Additional Intersection Improvements *Synchro* Worksheets

Weston Town Center Traffic Evaluation

- 1 RECONFIGURATION OF TOWN SHOPPING CENTER TO INCLUDE (5) TWO-STORY BUILDINGS WITH APPROX. 26,150 SF OF COMMERCIAL SPACE. 2ND STORY CAN ACCOMMODATE RESIDENTIAL OR OFFICE. INTERIOR SIDEWALKS CONNECT OUTDOOR PLAZAS TO THE SCULPTURE PARK ACROSS WESTON ROAD
- 2 MAINTAIN THE EXISTING CROSSING AND INCLUDE DESTINATION PLAZAS. PROVIDE PAINTED "SHARROWS" ALONG WESTON ROAD AND CONSTRUCT NEW SIDEWALKS AND INSTALL STREET TREES AND LIGHTING
- 3 DECORATIVE CROSSWALKS AND INTERSECTION STREET PRINT
- 4 CONVERT EXISTING COLONIAL HOME INTO COMMERCIAL SPACE AND CONSTRUCT (3) NEW SMALL COMMERCIAL BUILDINGS OF APPROX. 14,000 SF
- 5 REMOVE EXISTING HOME AND CONSTRUCT A SERIES OF (3) INTERCONNECTED BUILDINGS OF APPROX. 11,000 SF
- 6 MAINTAIN OVERFLOW PARKING ON CHURCH SITE AND CONSTRUCT NEW SIDEWALKS ALONG NORFIELD ROAD THAT CONNECT TO TOWN AMENITIES
- 7 CONVERT EXISTING COLONIAL HOME INTO COMMERCIAL SPACE AND ADD (3) NEW BUILDINGS OF APPROX. 7,500 SF. CONSIDER OFFICE OR RESIDENTIAL ON 2ND FLOOR AND PROVIDE DEDICATED PARKING
- 8 POTENTIAL LOCATION FOR RELOCATED ONION BARN AS A GATEWAY STATEMENT
- 9 CONVERT EXISTING COLONIAL HOME INTO COMMERCIAL SPACE WITH DEDICATED PARKING
- 10 RELOCATE ONION BARN AND CONSTRUCT (2) TWO-STORY MUNICIPAL OR COMMERCIAL BUILDINGS (10,300 SF) AND ADD DEDICATED PARKING
- 11 EXPAND EXISTING TOWN HALL PARKING LOT
- 12 FUTURE MEMORIAL WALK/ TOWN GREEN PROJECT
- 13 OPEN LAWN, LINEAR SCULPTURE PARK LINKS THE SCHOOLS AND SENIOR CENTER TO THE TOWN CENTER CORE. INSTALL 4' HT. MASONRY WALL OR FENCE, A VEGETATIVE BUFFER, SCULPTURES AND LANDSCAPING ALONG PATHWAYS
- 14 CONVERT BUS DEPOT BUILDING INTO A COMMUNITY/ ART CENTER WITH ASSOCIATED PARKING AND OUTDOOR EVENT SPACE AND RELOCATE BUS DEPOT FACILITY
- 15 DEDICATED PICK-UP/ DROP OFF AREA - DOUBLES AS FOOD TRUCK PARKING AREA



Figure 1
Weston Town Center Master Plan Preferred Concept

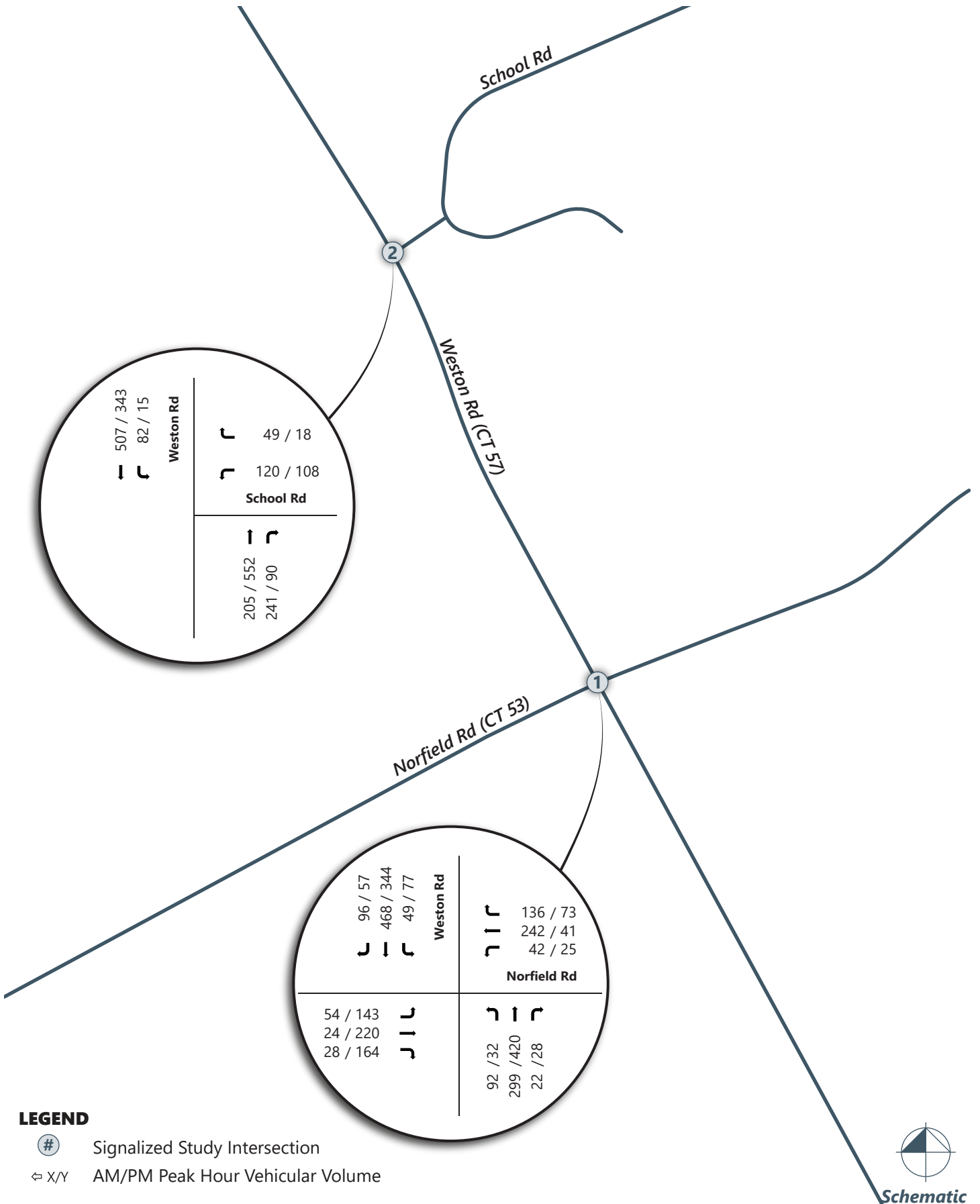

Schematic

Figure 2
Existing Peak Hour Volumes

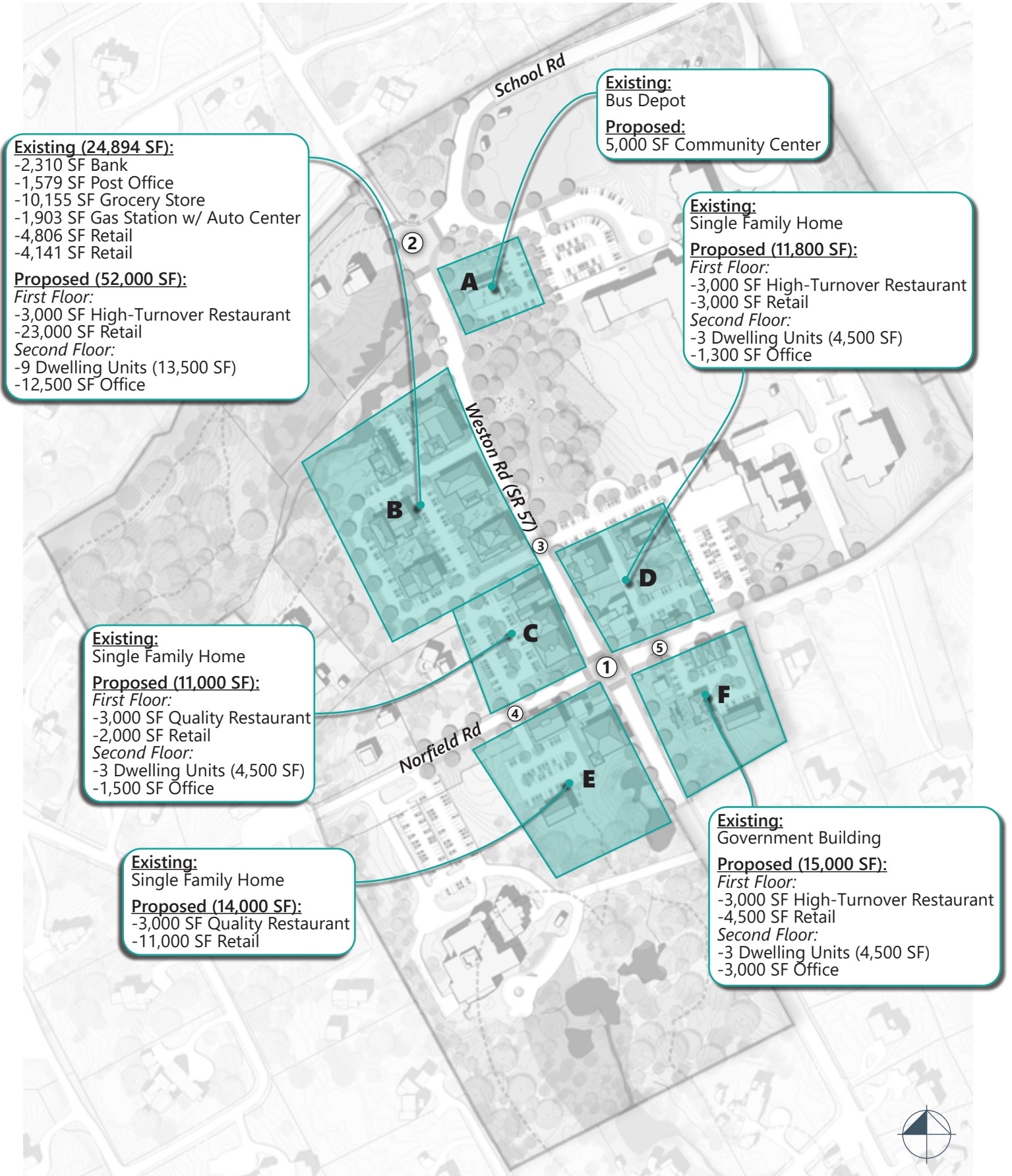

Figure 3
 Weston Town Center Preferred Concept Land Use Assumptions

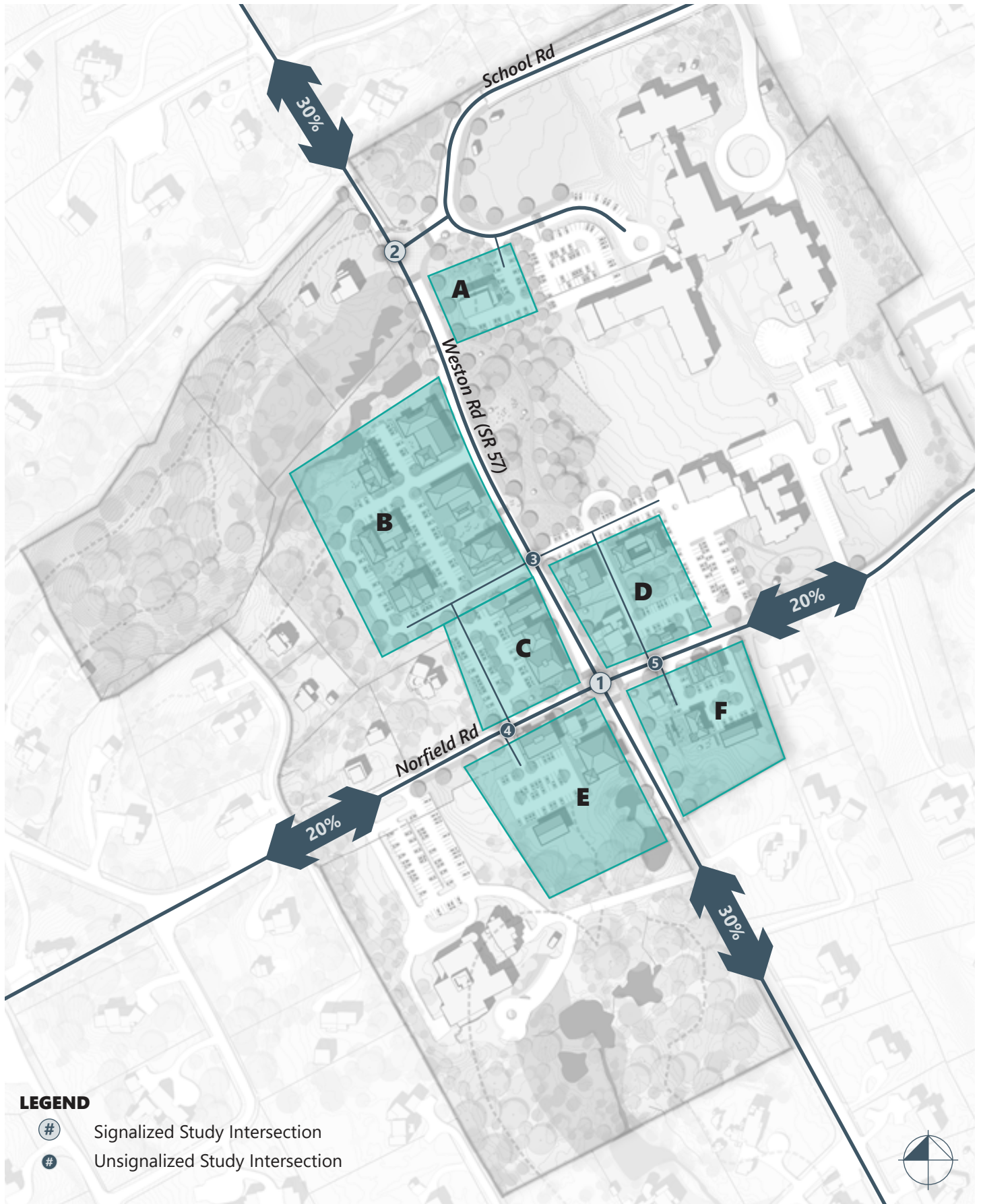

Figure 4
Weston Town Center Preferred Concept Distribution

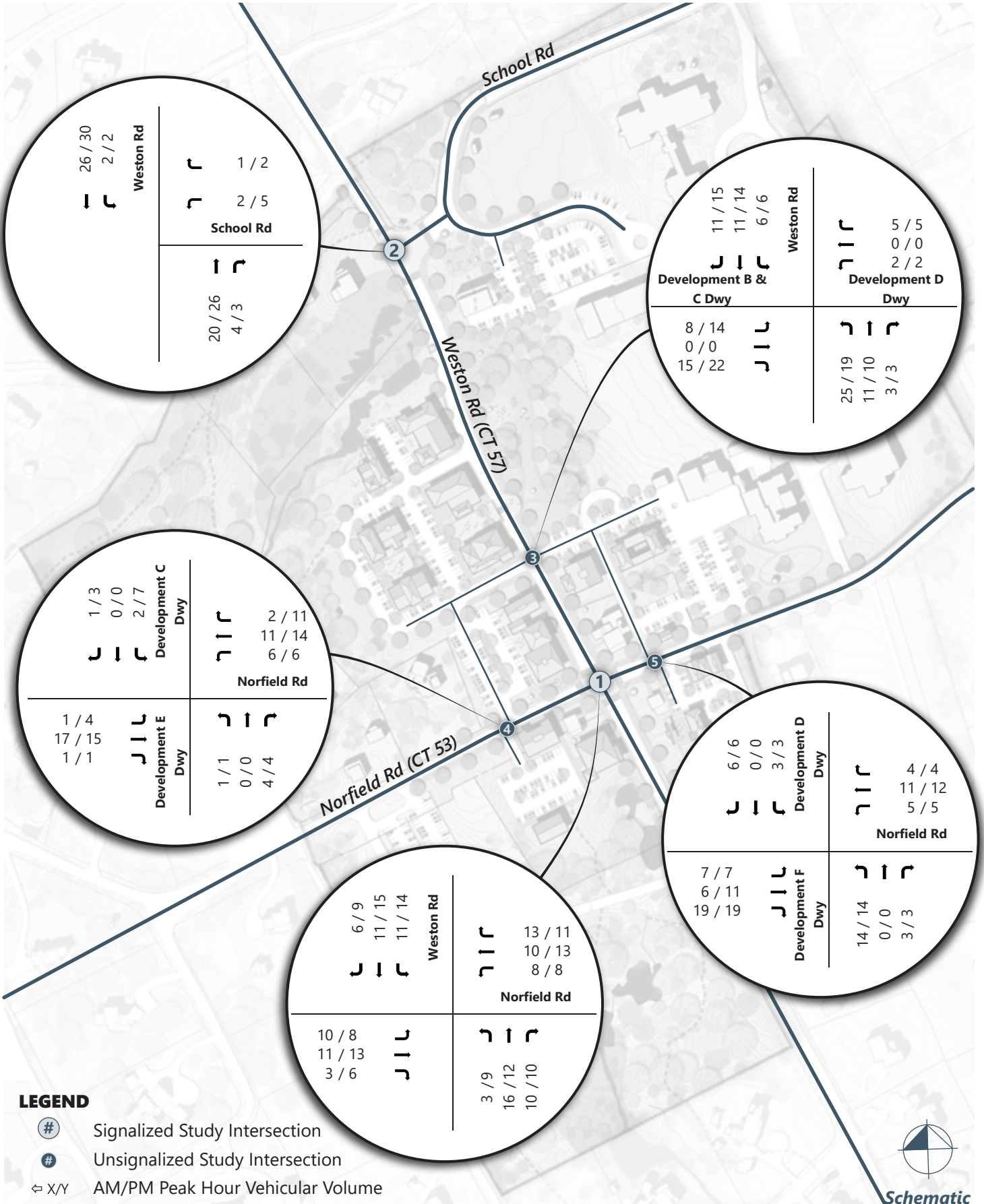

Figure 5 Weston Town Center Preferred Concept Peak Hour Volumes

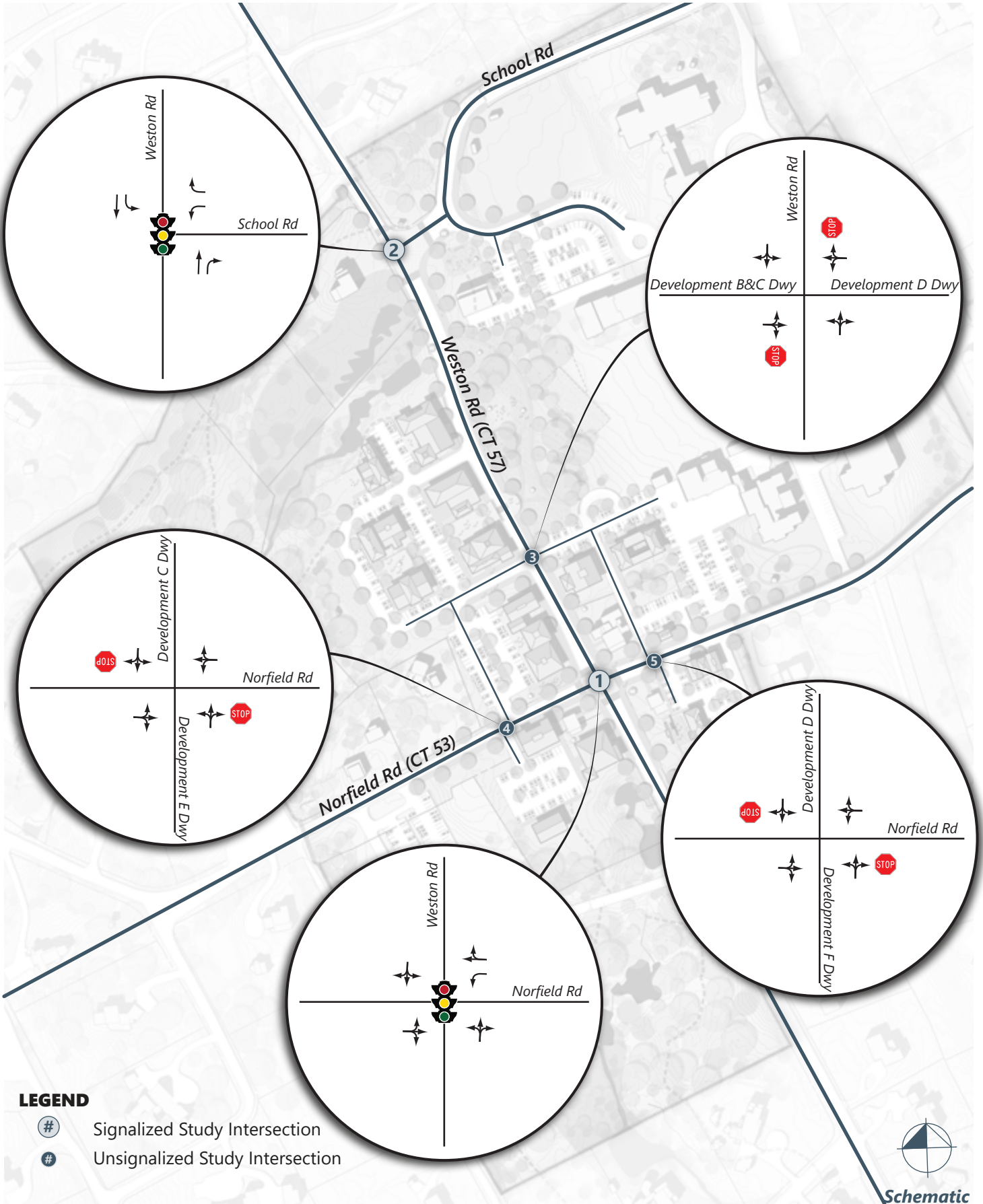

Figure 6
 Horizon Year (2049) Intersection Geometrics (Includes Funded Improvements)

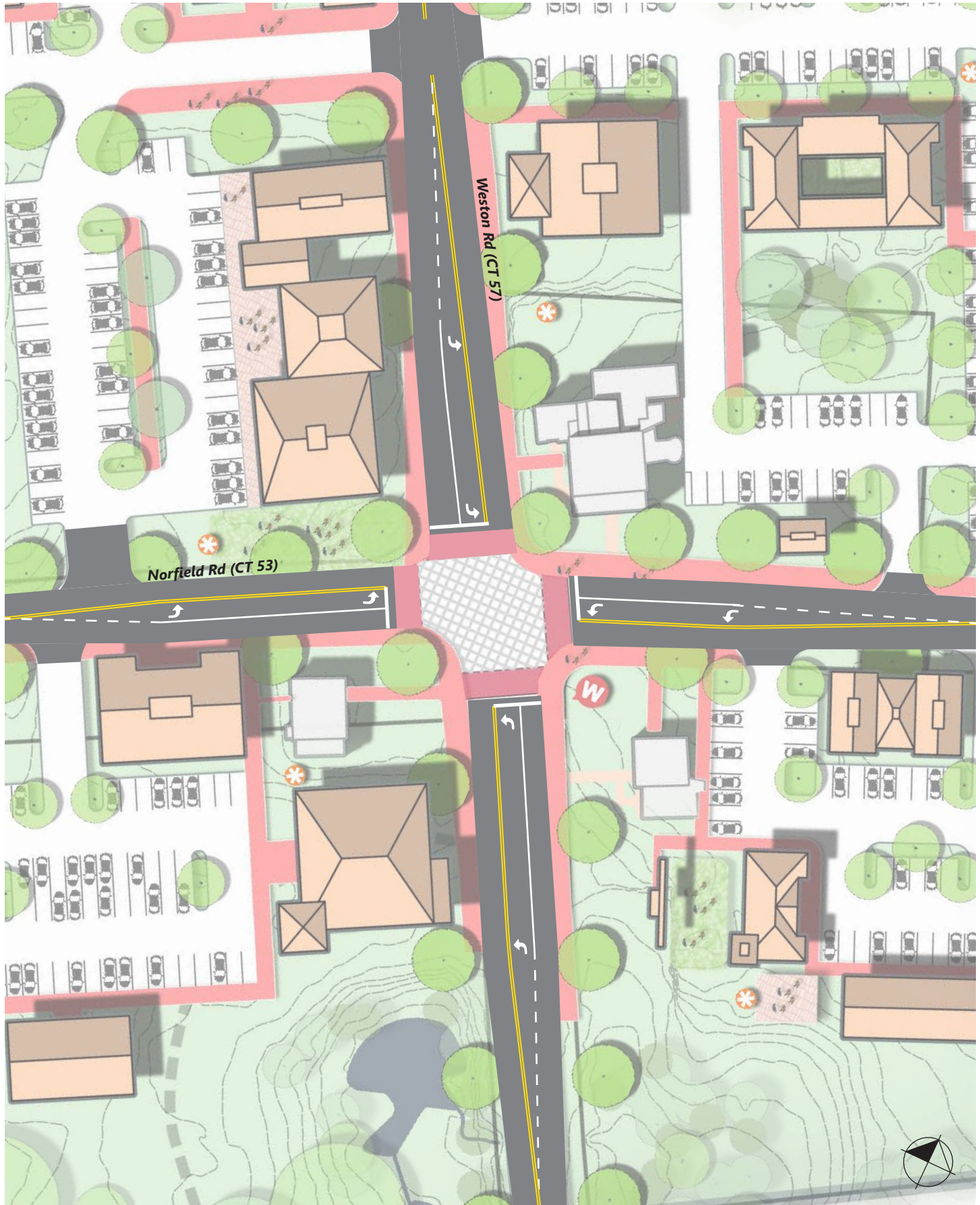

Figure 8
Proposed Intersection Mitigations at Weston Road and Norfield Road

APPENDIX

**A.M. TRAFFIC COUNTS (7:00 to 9:00 a.m.)
Locations 1 and 2
Thursday September 5, 2019
Weston, CT**



Reliable Traffic Counts, LLC
Vehicle/Data Collection Service

11 Branham Dr. East Haven, CT 06512 Tel: 203-530-2042 Fax: 203-469-0215 rtcfdc@aol.com

Weston Rd. at Norfield Rd.
A.M. TRAFFIC VOLUMES (7:00 to 9:00 A.M.)
Weston, CT
 prepared by Reliable Traffic Counts, LLC
 Weather Clear

ALL VEHICLES
 PEAK HOUR
 7:30 TO 8:30 A.M.

File Name : 1216-1TH
 Site Code : 00000002
 Start Date : 9/5/2019
 Page No : 1

Groups Printed- CARS - TRUCKS - BUSES

Start Time	RTE. 57 SOUTHBOUND					NORFIELD RD. WESTBOUND					WESTON RD. NORTHBOUND					NORFIELD RD. EASTBOUND					Int. Total
	Right	Thru	Left	Peds	App. Total	Right	Thru	Left	Peds	App. Total	Right	Thru	Left	Peds	App. Total	Right	Thru	Left	Peds	App. Total	
07:00 AM	15	89	11	0	115	16	45	4	0	65	0	60	14	0	74	2	5	14	0	21	275
07:15 AM	17	98	9	0	124	54	49	13	0	116	1	99	15	0	115	3	3	18	0	24	379
07:30 AM	21	135	12	0	168	43	67	18	0	128	3	65	27	0	95	6	4	16	0	26	417
07:45 AM	24	121	12	0	157	28	62	12	0	102	7	60	17	0	84	8	9	13	0	30	373
Total	77	443	44	0	564	141	223	47	0	411	11	284	73	0	368	19	21	61	0	101	1444
08:00 AM	19	89	8	0	116	32	47	7	0	86	4	87	24	0	115	8	7	13	0	28	345
08:15 AM	32	123	17	0	172	33	66	5	0	104	8	87	24	0	119	6	4	12	0	22	417
08:30 AM	20	157	13	0	190	14	45	10	0	69	2	54	18	0	74	12	6	4	0	22	355
08:45 AM	22	97	12	0	131	8	46	7	0	61	5	44	33	0	82	9	3	11	0	23	297
Total	93	466	50	0	609	87	204	29	0	320	19	272	99	0	390	35	20	40	0	95	1414
Grand Total	170	909	94	0	1173	228	427	76	0	731	30	556	172	0	758	54	41	101	0	196	2858
Apprch %	14.5	77.5	8	0		31.2	58.4	10.4	0		4	73.4	22.7	0		27.6	20.9	51.5	0		
Total %	5.9	31.8	3.3	0	41	8	14.9	2.7	0	25.6	1	19.5	6	0	26.5	1.9	1.4	3.5	0	6.9	
CARS	168	899	92	0	1159	219	426	74	0	719	30	541	171	0	742	54	39	97	0	190	2810
% CARS	98.8	98.9	97.9	0	98.8	96.1	99.8	97.4	0	98.4	100	97.3	99.4	0	97.9	100	95.1	96	0	96.9	98.3
TRUCKS	0	0	0	0	0	0	0	0	0	0	0	2	1	0	3	0	0	1	0	1	4
% TRUCKS	0	0	0	0	0	0	0	0	0	0	0	0.4	0.6	0	0.4	0	0	1	0	0.5	0.1
BUSES	2	10	2	0	14	9	1	2	0	12	0	13	0	0	13	0	2	3	0	5	44
% BUSES	1.2	1.1	2.1	0	1.2	3.9	0.2	2.6	0	1.6	0	2.3	0	0	1.7	0	4.9	3	0	2.6	1.5

Weston Rd. at Norfield Rd.
A.M. TRAFFIC VOLUMES (7:00 to 9:00 A.M.)
Weston, CT
prepared by Reliable Traffic Counts, LLC
Weather Clear

ALL VEHICLES
PEAK HOUR
7:30 TO 8:30 A.M.

File Name : 1216-1TH
Site Code : 00000002
Start Date : 9/5/2019
Page No : 2

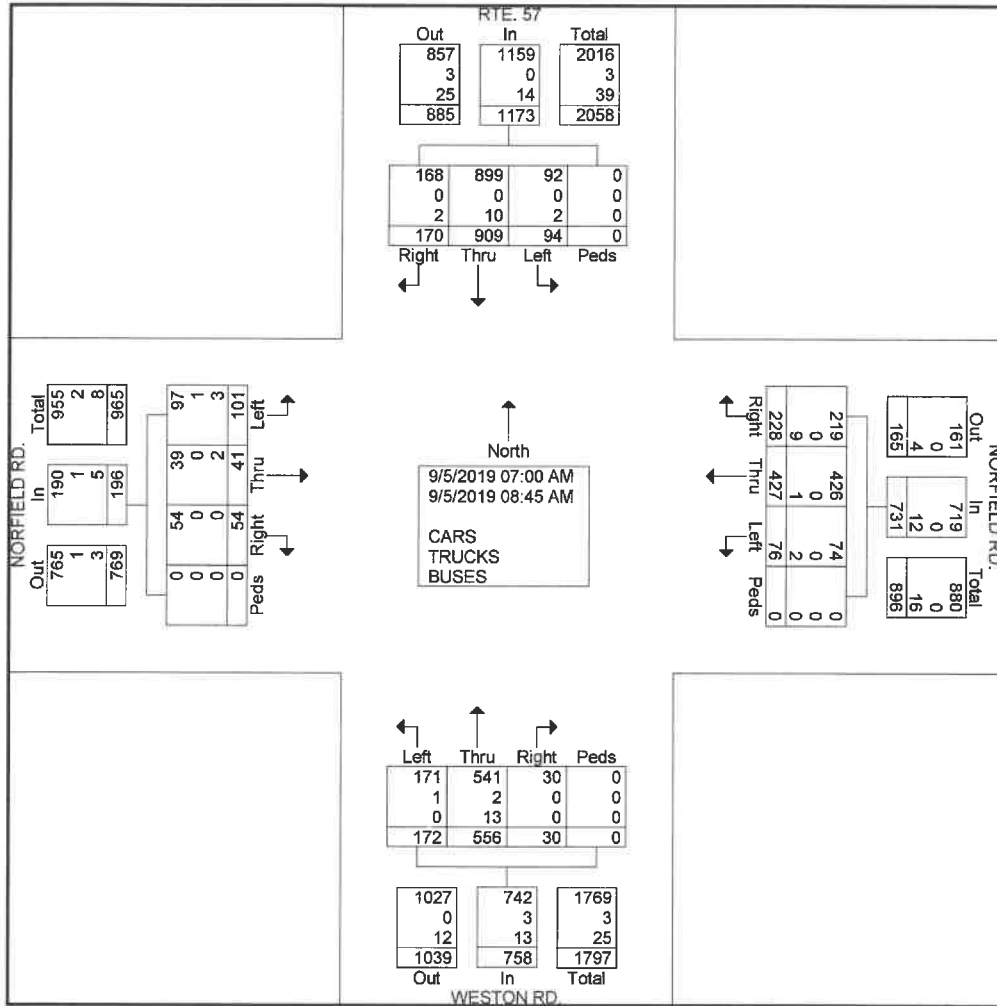

Weston Rd. at Norfield Rd.
A.M. TRAFFIC VOLUMES (7:00 to 9:00 A.M.)
 Weston, CT
 prepared by Reliable Traffic Counts, LLC
 Weather Clear

ALL VEHICLES
 PEAK HOUR
 7:30 TO 8:30 A.M.

File Name : 1216-1TH
 Site Code : 00000002
 Start Date : 9/5/2019
 Page No : 3

Start Time	RTE. 57 SOUTHBOUND					NORFIELD RD. WESTBOUND					WESTON RD. NORTHBOUND					NORFIELD RD. EASTBOUND					Int. Total
	Right	Thru	Left	Peds	App. Total	Right	Thru	Left	Peds	App. Total	Right	Thru	Left	Peds	App. Total	Right	Thru	Left	Peds	App. Total	
Peak Hour Analysis From 07:30 AM to 08:15 AM - Peak 1 of 1																					
Peak Hour for Entire Intersection Begins at 07:30 AM																					
07:30 AM	21	135	12	0	168	43	67	18	0	128	3	65	27	0	95	6	4	16	0	26	417
07:45 AM	24	121	12	0	157	28	62	12	0	102	7	60	17	0	84	8	9	13	0	30	373
08:00 AM	19	89	8	0	116	32	47	7	0	86	4	87	24	0	115	8	7	13	0	28	345
08:15 AM	32	123	17	0	172	33	66	5	0	104	8	87	24	0	119	6	4	12	0	22	417
Total Volume	96	468	49	0	613	136	242	42	0	420	22	299	92	0	413	28	24	54	0	106	1552
% App. Total	15.7	76.3	8	0		32.4	57.6	10	0		5.3	72.4	22.3	0		26.4	22.6	50.9	0		
PHF	.750	.867	.721	.000	.891	.791	.903	.583	.000	.820	.688	.859	.852	.000	.868	.875	.667	.844	.000	.883	.930

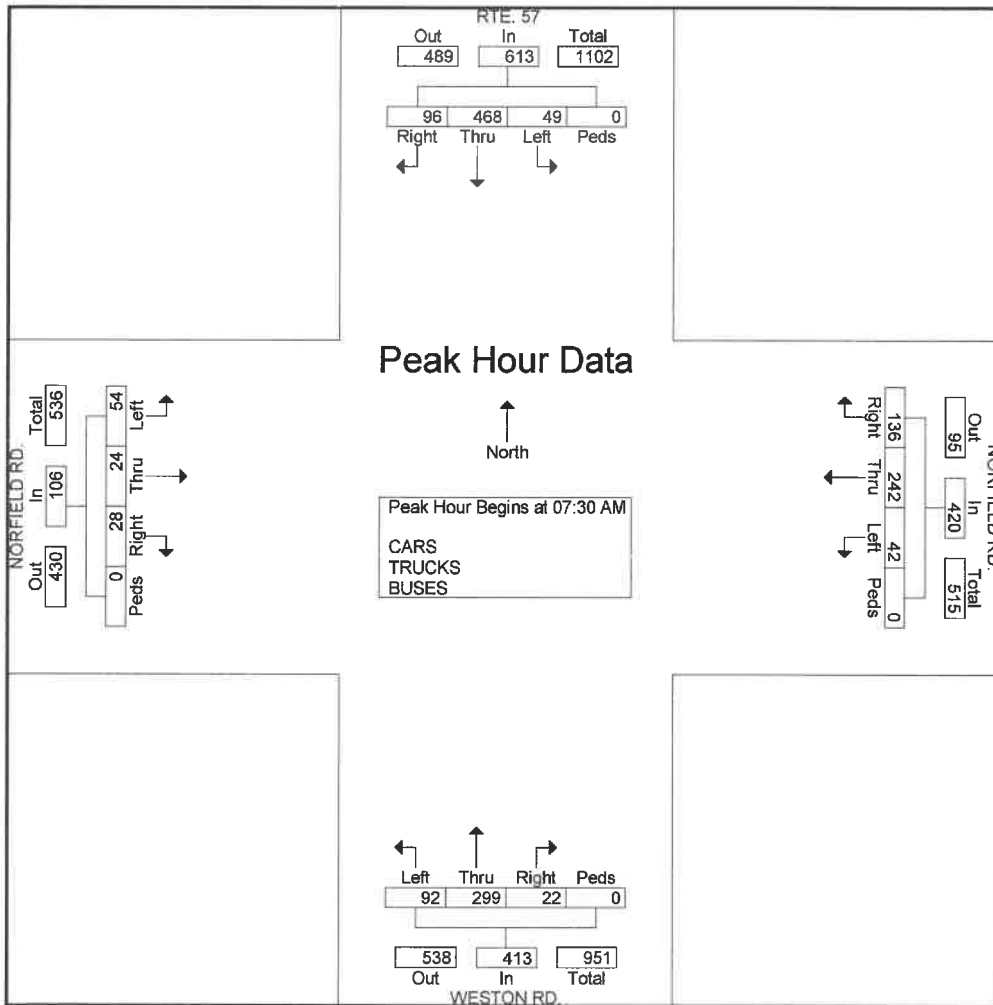

Weston Rd. at Norfield Rd.
A.M. TRAFFIC VOLUMES (7:00 to 9:00 A.M.)
Weston, CT
prepared by Reliable Traffic Counts, LLC
Weather Clear

CARS
PEAK HOUR
7:30 TO 8:30 A.M.

File Name : 1216-1TH
Site Code : 00000002
Start Date : 9/5/2019
Page No : 4

Groups Printed- CARS

Start Time	RTE. 57 SOUTHBOUND					NORFIELD RD. WESTBOUND					WESTON RD. NORTHBOUND					NORFIELD RD. EASTBOUND					Int. Total
	Right	Thru	Left	Peds	App. Total	Right	Thru	Left	Peds	App. Total	Right	Thru	Left	Peds	App. Total	Right	Thru	Left	Peds	App. Total	
07:00 AM	14	87	11	0	112	16	45	4	0	65	0	58	14	0	72	2	4	13	0	19	268
07:15 AM	17	97	9	0	123	50	49	13	0	112	1	93	15	0	109	3	3	17	0	23	367
07:30 AM	20	129	11	0	160	43	67	18	0	128	3	65	27	0	95	6	4	16	0	26	409
07:45 AM	24	121	12	0	157	28	62	10	0	100	7	59	17	0	83	8	8	13	0	29	369
Total	75	434	43	0	552	137	223	45	0	405	11	275	73	0	359	19	19	59	0	97	1413
08:00 AM	19	89	8	0	116	29	47	7	0	83	4	85	24	0	113	8	7	13	0	28	340
08:15 AM	32	122	17	0	171	31	66	5	0	102	8	83	23	0	114	6	4	11	0	21	408
08:30 AM	20	157	13	0	190	14	45	10	0	69	2	54	18	0	74	12	6	4	0	22	355
08:45 AM	22	97	11	0	130	8	45	7	0	60	5	44	33	0	82	9	3	10	0	22	294
Total	93	465	49	0	607	82	203	29	0	314	19	266	98	0	383	35	20	38	0	93	1397
Grand Total	168	899	92	0	1159	219	426	74	0	719	30	541	171	0	742	54	39	97	0	190	2810
Apprch %	14.5	77.6	7.9	0		30.5	59.2	10.3	0		4	72.9	23	0		28.4	20.5	51.1	0		
Total %	6	32	3.3	0	41.2	7.8	15.2	2.6	0	25.6	1.1	19.3	6.1	0	26.4	1.9	1.4	3.5	0	6.8	

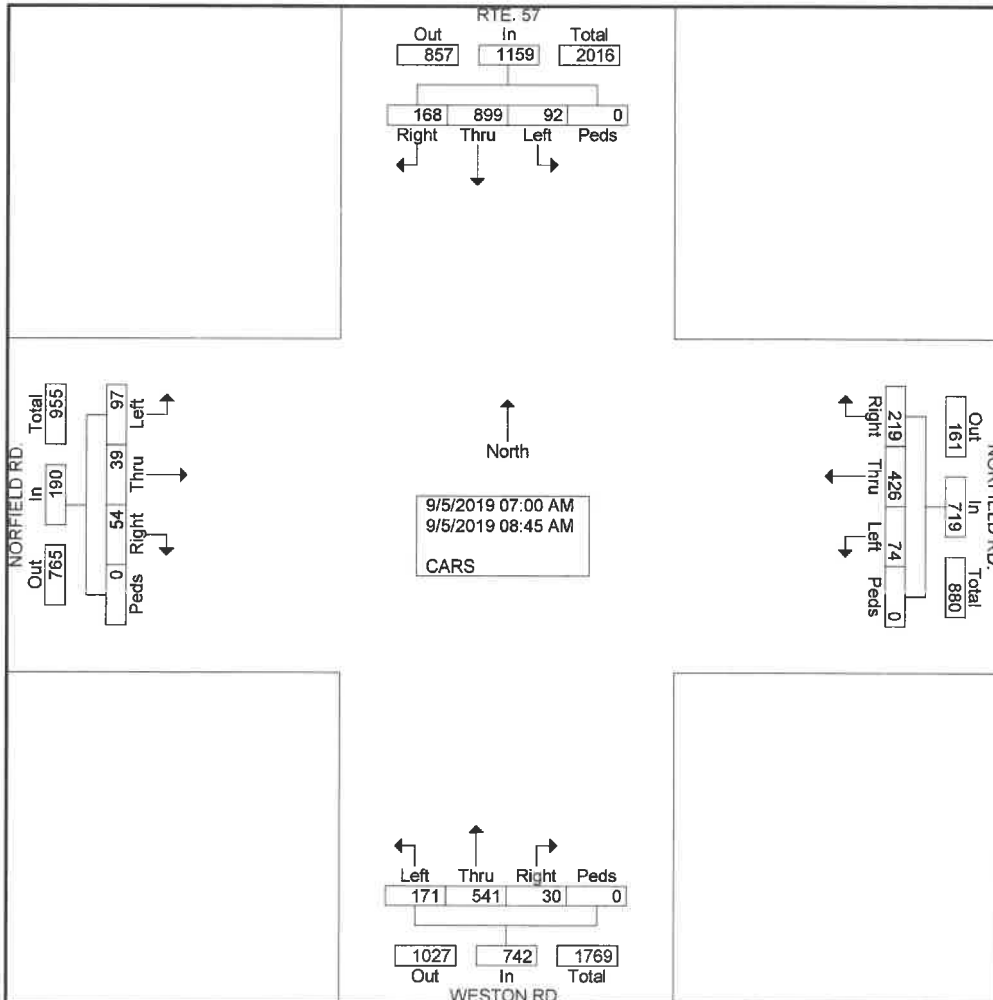

Weston Rd. at Norfield Rd.
A.M. TRAFFIC VOLUMES (7:00 to 9:00 A.M.)
Weston, CT
prepared by Reliable Traffic Counts, LLC
Weather Clear

TRUCKS
PEAK HOUR
7:30 TO 8:30 A.M.

File Name : 1216-1TH
Site Code : 00000002
Start Date : 9/5/2019
Page No : 5

Groups Printed- TRUCKS

Start Time	RTE. 57 SOUTHBOUND					NORFIELD RD. WESTBOUND					WESTON RD. NORTHBOUND					NORFIELD RD. EASTBOUND					Int. Total		
	Right	Thru	Left	Peds	App. Total	Right	Thru	Left	Peds	App. Total	Right	Thru	Left	Peds	App. Total	Right	Thru	Left	Peds	App. Total			
07:00 AM	0	0	0	0	0	0	0	0	0	0	0	1	0	0	1	0	0	0	0	0	0	0	1
07:15 AM	0	0	0	0	0	0	0	0	0	0	0	0	0	0	0	0	0	0	0	0	0	0	0
07:30 AM	0	0	0	0	0	0	0	0	0	0	0	0	0	0	0	0	0	0	0	0	0	0	0
07:45 AM	0	0	0	0	0	0	0	0	0	0	0	1	0	0	1	0	0	0	0	0	0	0	1
Total	0	0	0	0	0	0	0	0	0	0	0	2	0	0	2	0	0	0	0	0	0	0	2
08:00 AM	0	0	0	0	0	0	0	0	0	0	0	0	0	0	0	0	0	0	0	0	0	0	0
08:15 AM	0	0	0	0	0	0	0	0	0	0	0	0	1	0	1	0	0	0	0	0	0	0	1
08:30 AM	0	0	0	0	0	0	0	0	0	0	0	0	0	0	0	0	0	0	0	0	0	0	0
08:45 AM	0	0	0	0	0	0	0	0	0	0	0	0	0	0	0	0	0	1	0	1	0	1	1
Total	0	0	0	0	0	0	0	0	0	0	0	0	1	0	1	0	0	1	0	1	0	1	2
Grand Total	0	0	0	0	0	0	0	0	0	0	0	2	1	0	3	0	0	1	0	1	0	1	4
Apprch %	0	0	0	0	0	0	0	0	0	0	0	66.7	33.3	0	75	0	0	100	0	25	0	25	
Total %	0	0	0	0	0	0	0	0	0	0	0	50	25	0	75	0	0	25	0	25	0	25	

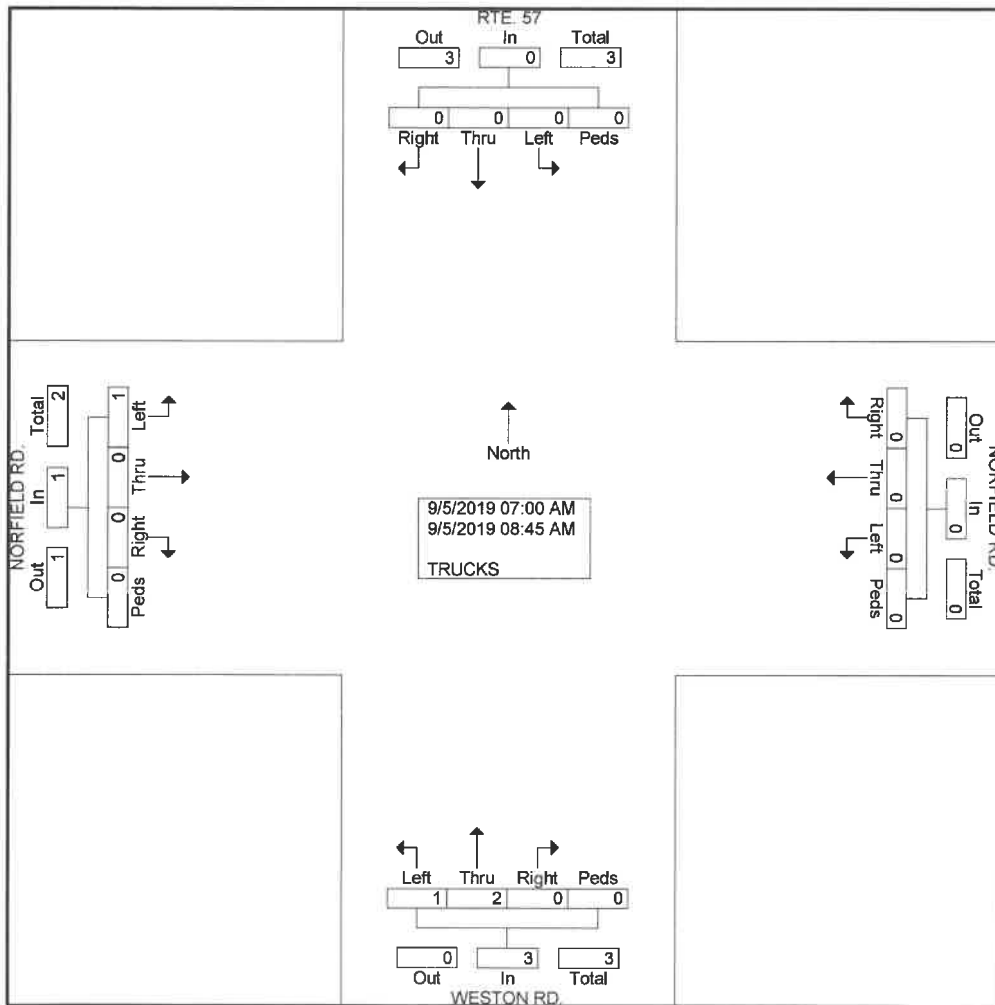

Weston Rd. at Norfield Rd.
A.M. TRAFFIC VOLUMES (7:00 to 9:00 A.M.)
Weston, CT
prepared by Reliable Traffic Counts, LLC
Weather Clear

BUSES
PEAK HOUR
7:30 TO 8:30 A.M.

File Name : 1216-1TH
Site Code : 00000002
Start Date : 9/5/2019
Page No : 6

Groups Printed- BUSES

Start Time	RTE. 57 SOUTHBOUND					NORFIELD RD. WESTBOUND					WESTON RD. NORTHBOUND					NORFIELD RD. EASTBOUND					Int. Total
	Right	Thru	Left	Peds	App. Total	Right	Thru	Left	Peds	App. Total	Right	Thru	Left	Peds	App. Total	Right	Thru	Left	Peds	App. Total	
07:00 AM	1	2	0	0	3	0	0	0	0	0	0	1	0	0	1	0	1	1	0	2	6
07:15 AM	0	1	0	0	1	4	0	0	0	4	0	6	0	0	6	0	0	1	0	1	12
07:30 AM	1	6	1	0	8	0	0	0	0	0	0	0	0	0	0	0	0	0	0	0	8
07:45 AM	0	0	0	0	0	0	0	2	0	2	0	0	0	0	0	0	1	0	0	1	3
Total	2	9	1	0	12	4	0	2	0	6	0	7	0	0	7	0	2	2	0	4	29
08:00 AM	0	0	0	0	0	3	0	0	0	3	0	2	0	0	2	0	0	0	0	0	5
08:15 AM	0	1	0	0	1	2	0	0	0	2	0	4	0	0	4	0	0	1	0	1	8
08:30 AM	0	0	0	0	0	0	0	0	0	0	0	0	0	0	0	0	0	0	0	0	0
08:45 AM	0	0	1	0	1	0	1	0	0	1	0	0	0	0	0	0	0	0	0	0	2
Total	0	1	1	0	2	5	1	0	0	6	0	6	0	0	6	0	0	1	0	1	15
Grand Total	2	10	2	0	14	9	1	2	0	12	0	13	0	0	13	0	2	3	0	5	44
Apprch %	14.3	71.4	14.3	0		75	8.3	16.7	0		0	100	0	0		0	40	60	0		
Total %	4.5	22.7	4.5	0	31.8	20.5	2.3	4.5	0	27.3	0	29.5	0	0	29.5	0	4.5	6.8	0	11.4	

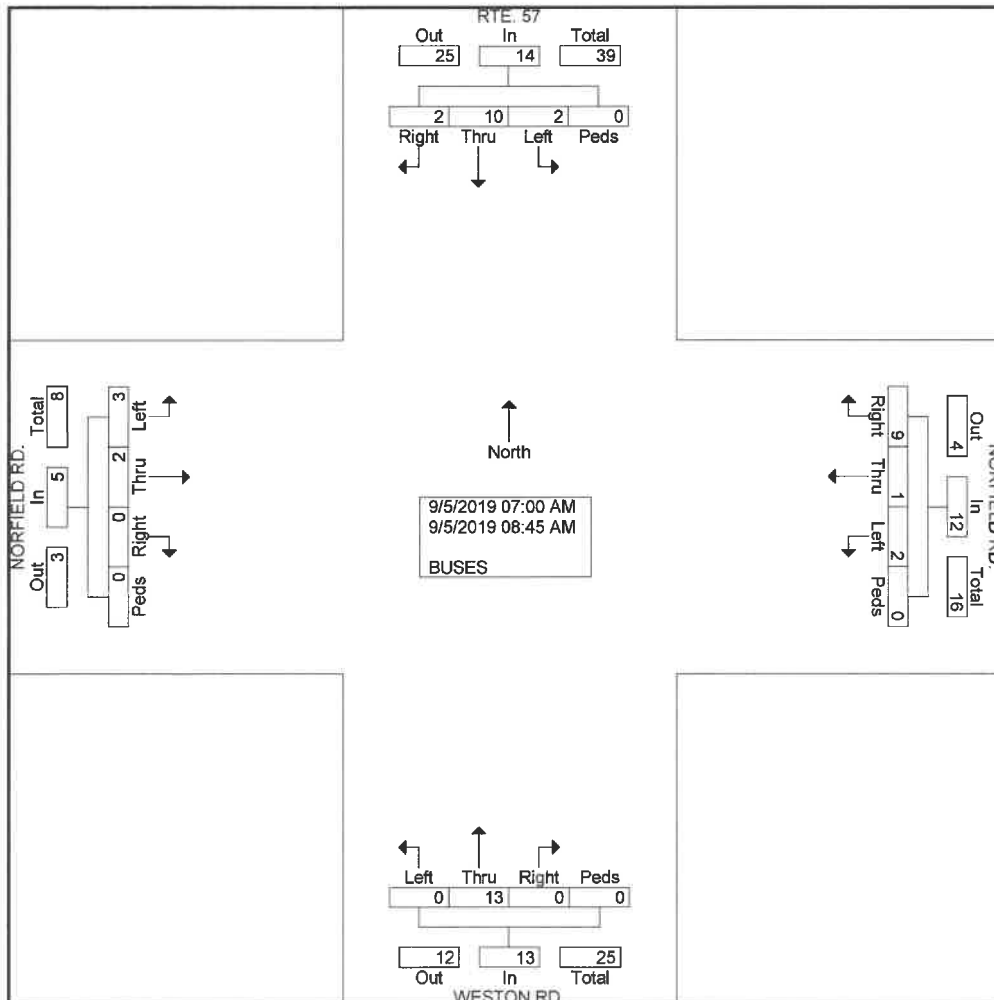

Weston Rd. at School Rd.
A.M. TRAFFIC VOLUMES (7:00 to 9:00 A.M.)
Weston, CT
prepared by Reliable Traffic Counts, LLC
Weather Clear

ALL VEHICLES
PEAK HOUR
7:45 TO 8:45 A.M.

File Name : 1216-2TH
Site Code : 00000002
Start Date : 9/5/2019
Page No : 1

Groups Printed- CARS - TRUCKS - BUSES

Start Time	WESTON RD. SOUTHBOUND				SCHOOL RD. WESTBOUND				WESTON RD. NORTHBOUND				EASTBOUND		Int. Total
	Thru	Left	Peds	App. Total	Right	Left	Peds	App. Total	Right	Thru	Peds	App. Total	Peds	App. Total	
07:00 AM	42	6	0	48	1	8	0	9	24	22	0	46	0	0	103
07:15 AM	115	28	0	143	3	19	0	22	115	43	0	158	0	0	323
07:30 AM	155	27	0	182	18	23	0	41	83	36	0	119	0	0	342
07:45 AM	133	16	0	149	2	8	0	10	34	54	0	88	0	0	247
Total	445	77	0	522	24	58	0	82	256	155	0	411	0	0	1015
08:00 AM	108	23	0	131	1	1	0	2	61	58	0	119	0	0	252
08:15 AM	111	16	0	127	28	88	0	116	63	57	0	120	0	0	363
08:30 AM	156	8	0	164	6	35	0	41	16	52	0	68	0	0	273
08:45 AM	103	6	0	109	2	14	0	16	7	48	0	55	0	0	180
Total	478	53	0	531	37	138	0	175	147	215	0	362	0	0	1068
Grand Total	923	130	0	1053	61	196	0	257	403	370	0	773	0	0	2083
Apprch %	87.7	12.3	0		23.7	76.3	0		52.1	47.9	0		0		
Total %	44.3	6.2	0	50.6	2.9	9.4	0	12.3	19.3	17.8	0	37.1	0	0	
CARS	922	125	0	1047	59	191	0	250	379	362	0	741	0	0	2038
% CARS	99.9	96.2	0	99.4	96.7	97.4	0	97.3	94	97.8	0	95.9	0	0	97.8
TRUCKS	0	0	0	0	0	0	0	0	0	2	0	2	0	0	2
% TRUCKS	0	0	0	0	0	0	0	0	0	0.5	0	0.3	0	0	0.1
BUSES	1	5	0	6	2	5	0	7	24	6	0	30	0	0	43
% BUSES	0.1	3.8	0	0.6	3.3	2.6	0	2.7	6	1.6	0	3.9	0	0	2.1

Weston Rd. at School Rd.
A.M. TRAFFIC VOLUMES (7:00 to 9:00 A.M.)
Weston, CT
prepared by Reliable Traffic Counts, LLC
Weather Clear

ALL VEHICLES
PEAK HOUR
7:45 TO 8:45 A.M.

File Name : 1216-2TH
Site Code : 00000002
Start Date : 9/5/2019
Page No : 2

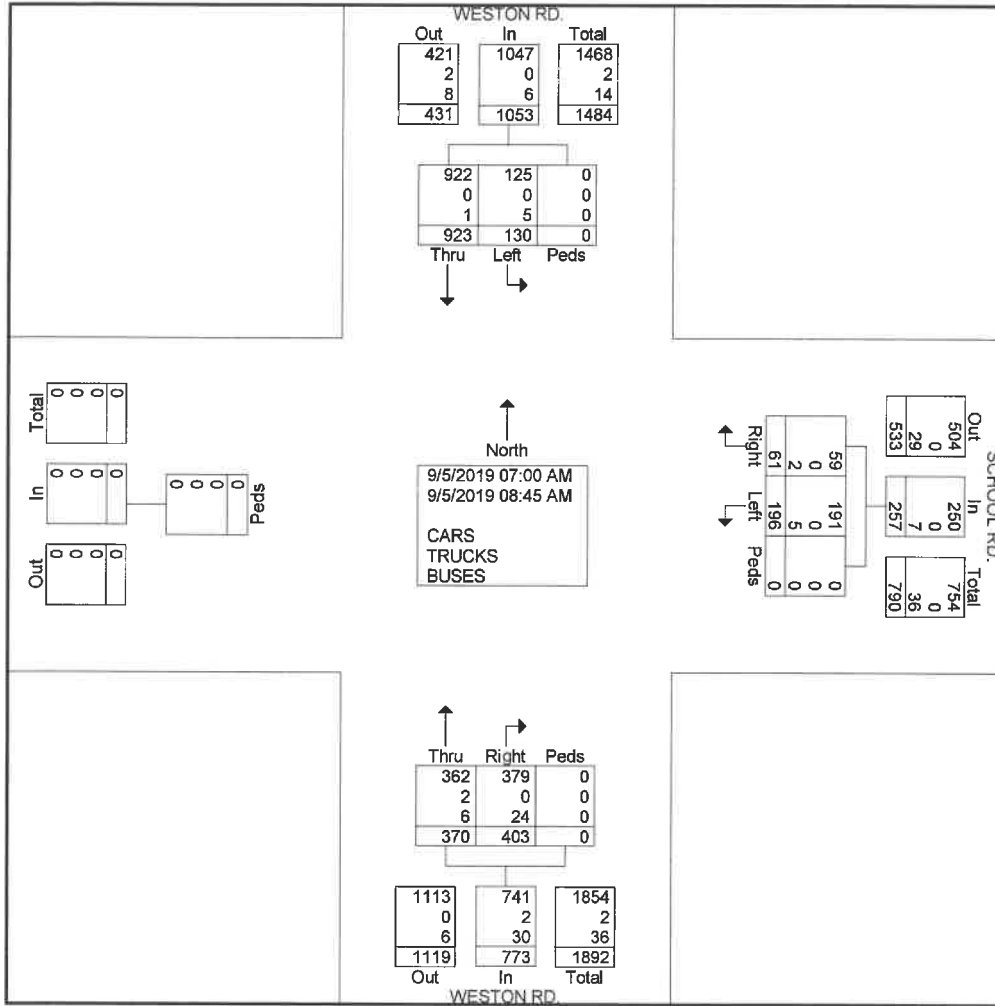

Weston Rd. at School Rd.
A.M. TRAFFIC VOLUMES (7:00 to 9:00 A.M.)
Weston, CT
prepared by Reliable Traffic Counts, LLC
Weather Clear

ALL VEHICLES
PEAK HOUR
7:45 TO 8:45 A.M.

File Name : 1216-2TH
Site Code : 00000002
Start Date : 9/5/2019
Page No : 3

Start Time	WESTON RD. SOUTHBOUND				SCHOOL RD. WESTBOUND				WESTON RD. NORTHBOUND				EASTBOUND		Int. Total	
	Thru	Left	Peds	App. Total	Right	Left	Peds	App. Total	Right	Thru	Peds	App. Total	Peds	App. Total		
Peak Hour Analysis From 07:45 AM to 08:30 AM - Peak 1 of 1																
Peak Hour for Entire Intersection Begins at 07:45 AM																
07:45 AM	133	16	0	149	2	8	0	10	34	54	0	88	0	0	247	
08:00 AM	108	23	0	131	1	1	0	2	61	58	0	119	0	0	252	
08:15 AM	111	16	0	127	28	88	0	116	63	57	0	120	0	0	363	
08:30 AM	156	8	0	164	6	35	0	41	16	52	0	68	0	0	273	
Total Volume	508	63	0	571	37	132	0	169	174	221	0	395	0	0	1135	
% App. Total	89	11	0		21.9	78.1	0		44.1	55.9	0		0			
PHF	.814	.685	.000	.870	.330	.375	.000	.364	.690	.953	.000	.823	.000	.000	.782	

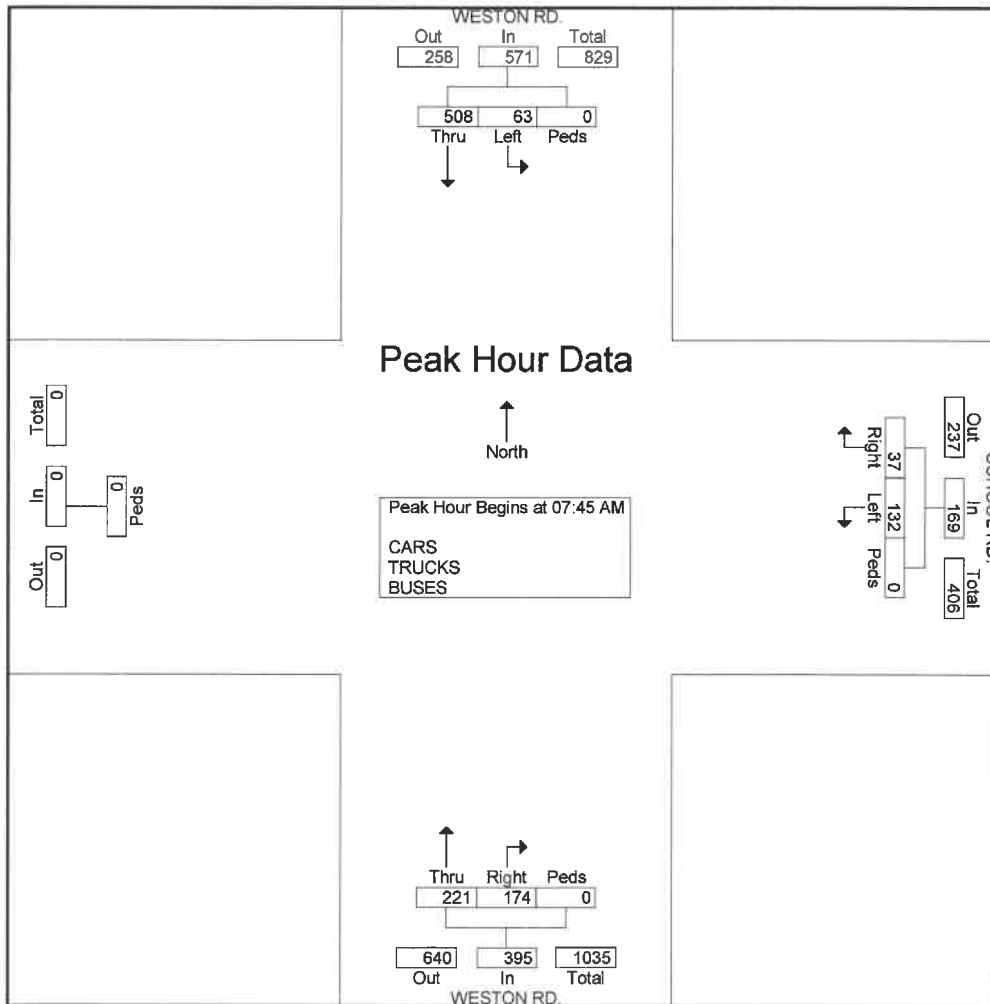

Weston Rd. at School Rd.
A.M. TRAFFIC VOLUMES (7:00 to 9:00 A.M.)
Weston, CT
prepared by Reliable Traffic Counts, LLC
Weather Clear

CARS
PEAK HOUR
7:45 TO 8:45 A.M.

File Name : 1216-2TH
Site Code : 00000002
Start Date : 9/5/2019
Page No : 4

Groups Printed- CARS

Start Time	WESTON RD. SOUTHBOUND				SCHOOL RD. WESTBOUND				WESTON RD. NORTHBOUND				EASTBOUND		Int. Total
	Thru	Left	Peds	App. Total	Right	Left	Peds	App. Total	Right	Thru	Peds	App. Total	Peds	App. Total	
07:00 AM	42	6	0	48	1	8	0	9	23	20	0	43	0	0	100
07:15 AM	115	26	0	141	3	19	0	22	106	42	0	148	0	0	311
07:30 AM	154	27	0	181	16	20	0	36	82	34	0	116	0	0	333
07:45 AM	133	15	0	148	2	7	0	9	34	52	0	86	0	0	243
Total	444	74	0	518	22	54	0	76	245	148	0	393	0	0	987
08:00 AM	108	22	0	130	1	1	0	2	59	57	0	116	0	0	248
08:15 AM	111	15	0	126	28	87	0	115	53	57	0	110	0	0	351
08:30 AM	156	8	0	164	6	35	0	41	16	52	0	68	0	0	273
08:45 AM	103	6	0	109	2	14	0	16	6	48	0	54	0	0	179
Total	478	51	0	529	37	137	0	174	134	214	0	348	0	0	1051
Grand Total	922	125	0	1047	59	191	0	250	379	362	0	741	0	0	2038
Apprch %	88.1	11.9	0		23.6	76.4	0		51.1	48.9	0		0		
Total %	45.2	6.1	0	51.4	2.9	9.4	0	12.3	18.6	17.8	0	36.4	0	0	

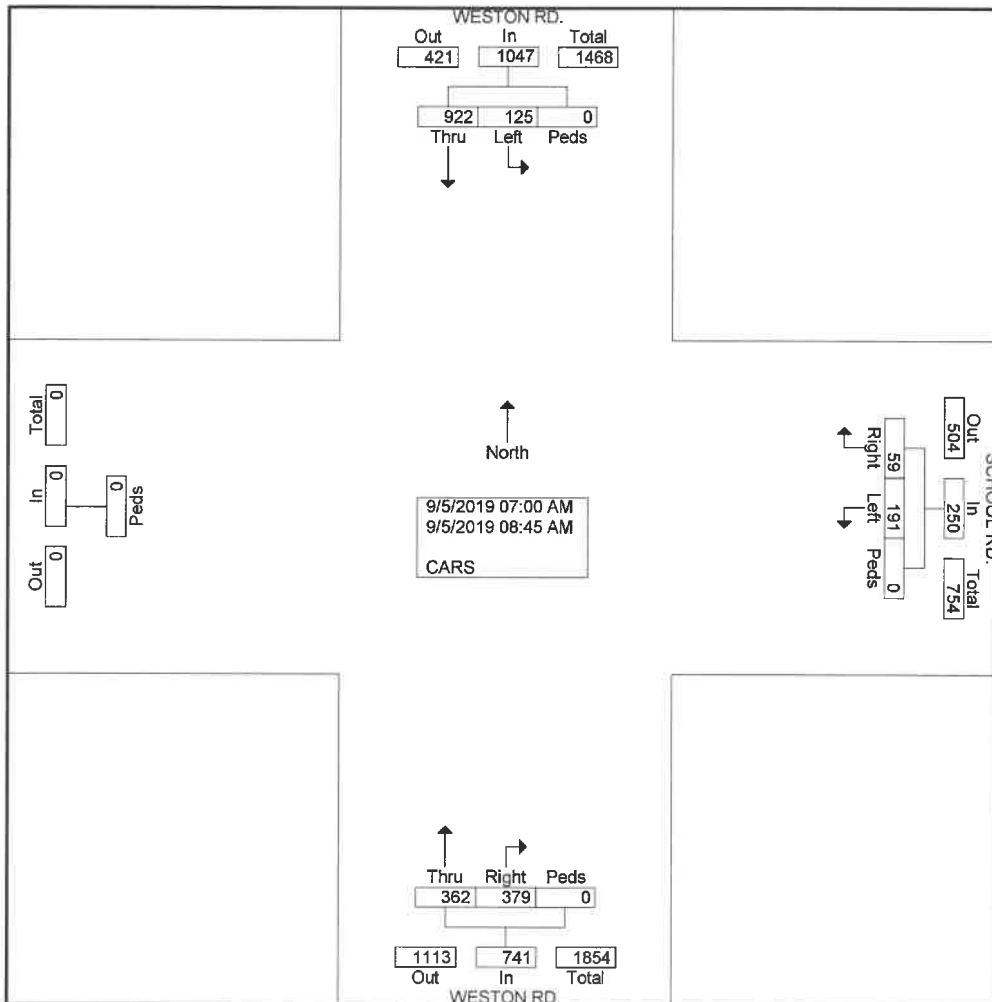

Weston Rd. at School Rd.
A.M. TRAFFIC VOLUMES (7:00 to 9:00 A.M.)
Weston, CT
prepared by Reliable Traffic Counts, LLC
Weather Clear

TRUCKS
PEAK HOUR
7:45 TO 8:45 A.M.

File Name : 1216-2TH
Site Code : 00000002
Start Date : 9/5/2019
Page No : 5

Groups Printed- TRUCKS

Start Time	WESTON RD. SOUTHBOUND				SCHOOL RD. WESTBOUND				WESTON RD. NORTHBOUND				EASTBOUND		
	Thru	Left	Peds	App. Total	Right	Left	Peds	App. Total	Right	Thru	Peds	App. Total	Peds	App. Total	Int. Total
07:00 AM	0	0	0	0	0	0	0	0	0	1	0	1	0	0	1
07:15 AM	0	0	0	0	0	0	0	0	0	0	0	0	0	0	0
07:30 AM	0	0	0	0	0	0	0	0	0	0	0	0	0	0	0
07:45 AM	0	0	0	0	0	0	0	0	0	1	0	1	0	0	1
Total	0	0	0	0	0	0	0	0	0	2	0	2	0	0	2
08:00 AM	0	0	0	0	0	0	0	0	0	0	0	0	0	0	0
08:15 AM	0	0	0	0	0	0	0	0	0	0	0	0	0	0	0
08:30 AM	0	0	0	0	0	0	0	0	0	0	0	0	0	0	0
08:45 AM	0	0	0	0	0	0	0	0	0	0	0	0	0	0	0
Total	0	0	0	0	0	0	0	0	0	0	0	0	0	0	0
Grand Total	0	0	0	0	0	0	0	0	0	2	0	2	0	0	2
Apprch %	0	0	0	0	0	0	0	0	0	100	0	100	0	0	0
Total %	0	0	0	0	0	0	0	0	0	100	0	100	0	0	0

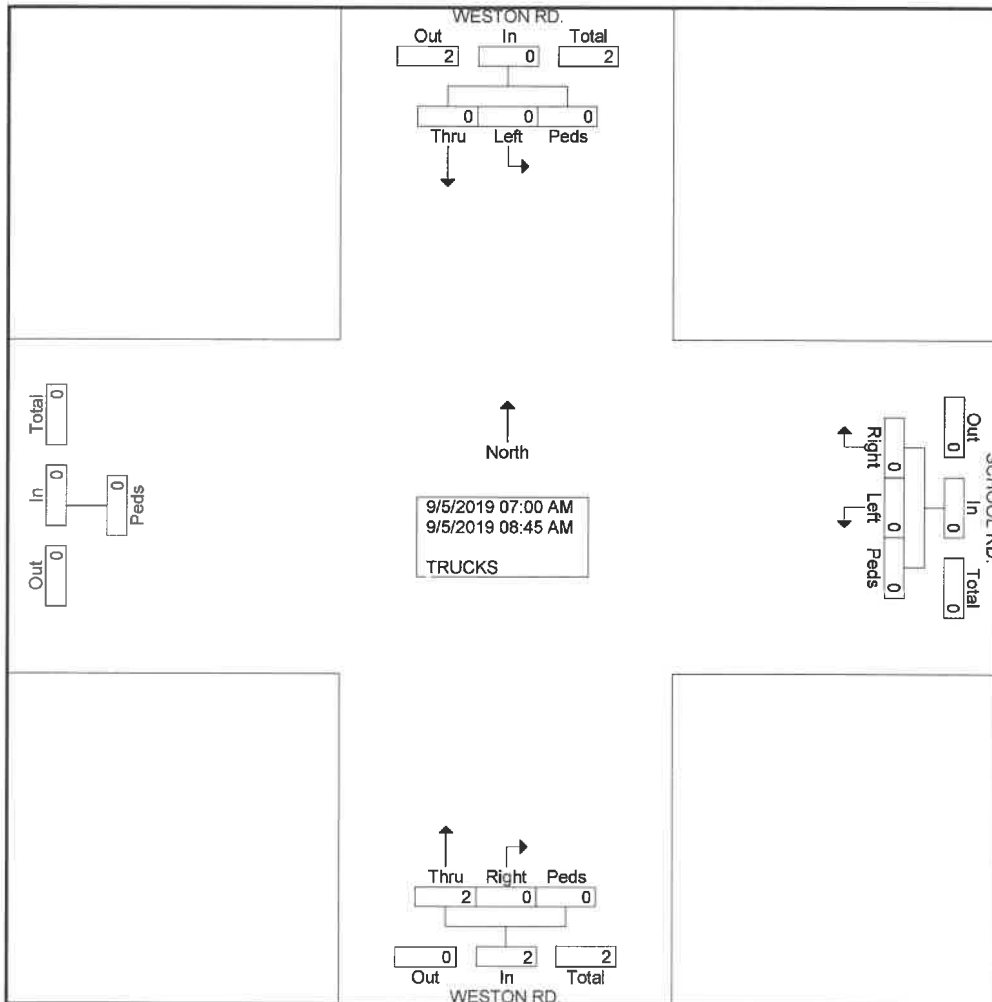

Weston Rd. at School Rd.
A.M. TRAFFIC VOLUMES (7:00 to 9:00 A.M.)
Weston, CT
prepared by Reliable Traffic Counts, LLC
Weather Clear

BUSES
PEAK HOUR
7:45 TO 8:45 A.M.

File Name : 1216-2TH
Site Code : 00000002
Start Date : 9/5/2019
Page No : 6

Groups Printed- BUSES

Start Time	WESTON RD. SOUTHBOUND				SCHOOL RD. WESTBOUND				WESTON RD. NORTHBOUND				EASTBOUND		Int. Total
	Thru	Left	Peds	App. Total	Right	Left	Peds	App. Total	Right	Thru	Peds	App. Total	Peds	App. Total	
07:00 AM	0	0	0	0	0	0	0	0	1	1	0	2	0	0	2
07:15 AM	0	2	0	2	0	0	0	0	9	1	0	10	0	0	12
07:30 AM	1	0	0	1	2	3	0	5	1	2	0	3	0	0	9
07:45 AM	0	1	0	1	0	1	0	1	0	1	0	1	0	0	3
Total	1	3	0	4	2	4	0	6	11	5	0	16	0	0	26
08:00 AM	0	1	0	1	0	0	0	0	2	1	0	3	0	0	4
08:15 AM	0	1	0	1	0	1	0	1	10	0	0	10	0	0	12
08:30 AM	0	0	0	0	0	0	0	0	0	0	0	0	0	0	0
08:45 AM	0	0	0	0	0	0	0	0	1	0	0	1	0	0	1
Total	0	2	0	2	0	1	0	1	13	1	0	14	0	0	17
Grand Total	1	5	0	6	2	5	0	7	24	6	0	30	0	0	43
Apprch %	16.7	83.3	0		28.6	71.4	0		80	20	0		0	0	
Total %	2.3	11.6	0	14	4.7	11.6	0	16.3	55.8	14	0	69.8	0	0	

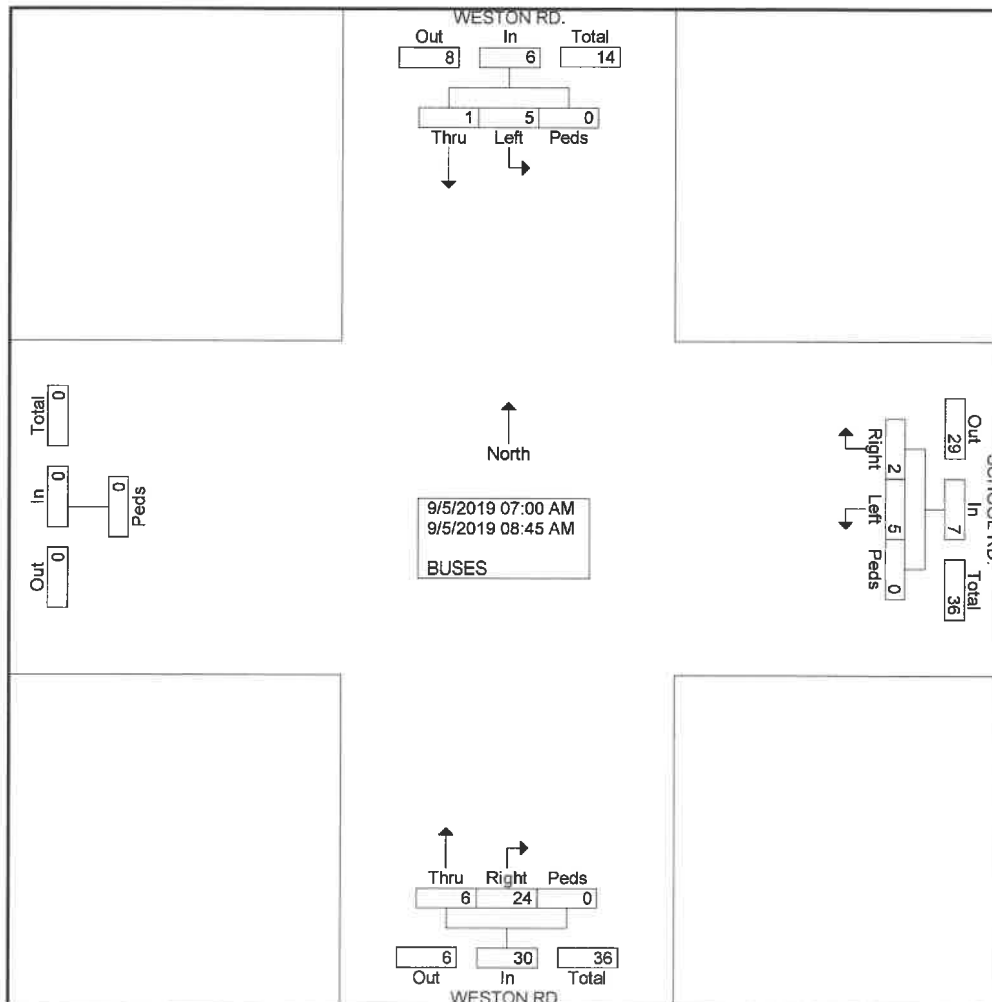

***P.M. TRAFFIC COUNTS (2:00 to 6:00 p.m.)
Locations 1 and 2
Thursday September 5, 2019
Weston, CT***



Reliable Traffic Counts, LLC
Vehicle/Data Collection Service

11 Branhaven Dr. East Haven, CT 06512 Tel. 203-530-2042 Fax: 203-469-0215 rtcvc@rol.com

Weston Rd. at Norfield Rd.
A.M. TRAFFIC VOLUMES (7:00 to 9:00 A.M.)
 Weston, CT
 prepared by Reliable Traffic Counts, LLC
 Weather Clear

ALL VEHICLES
 PEAK HOUR
 5:00 TO 6:00 P.M.

File Name : 1216-1TH
 Site Code : 00000002
 Start Date : 9/5/2019
 Page No : 1

Groups Printed- CARS - TRUCKS - BUSES

Start Time	RTE. 57 SOUTHBOUND					NORFIELD RD. WESTBOUND					WESTON RD. NORTHBOUND					NORFIELD RD. EASTBOUND					Int. Total
	Right	Thru	Left	Peds	App. Total	Right	Thru	Left	Peds	App. Total	Right	Thru	Left	Peds	App. Total	Right	Thru	Left	Peds	App. Total	
02:00 PM	13	71	16	0	100	22	12	3	0	37	8	85	10	0	103	9	12	19	0	40	280
02:15 PM	13	84	14	0	111	22	9	12	0	43	10	90	12	0	112	12	12	20	0	44	310
02:30 PM	13	131	23	0	167	18	7	4	0	29	4	87	8	0	99	8	5	13	0	26	321
02:45 PM	7	97	21	1	126	27	6	5	0	38	11	84	10	0	105	15	14	20	0	49	318
Total	46	383	74	1	504	89	34	24	0	147	33	346	40	0	419	44	43	72	0	159	1229
03:00 PM	11	88	14	0	113	24	7	10	0	41	5	96	4	0	105	21	17	28	0	66	325
03:15 PM	18	76	24	0	118	13	6	9	0	28	5	115	14	0	134	26	30	13	2	71	351
03:30 PM	13	100	22	0	135	17	14	12	0	43	9	78	9	0	96	33	36	23	0	92	366
03:45 PM	21	67	16	0	104	11	14	8	3	36	10	108	4	0	122	32	49	32	0	113	375
Total	63	331	76	0	470	65	41	39	3	148	29	397	31	0	457	112	132	96	2	342	1417
04:00 PM	18	82	18	1	119	13	5	6	0	24	3	108	6	0	117	42	63	25	0	130	390
04:15 PM	9	84	26	1	120	25	8	7	0	40	10	108	7	0	125	29	69	38	0	136	421
04:30 PM	16	96	22	0	134	28	7	7	0	42	4	106	4	0	114	30	46	43	0	119	409
04:45 PM	15	92	20	0	127	25	10	7	0	42	5	100	4	0	109	32	45	40	0	117	395
Total	58	354	86	2	500	91	30	27	0	148	22	422	21	0	465	133	223	146	0	502	1615
05:00 PM	13	91	17	0	121	18	14	6	0	38	8	98	10	0	116	37	59	29	0	125	400
05:15 PM	8	75	19	0	102	16	9	8	0	33	5	122	4	0	131	47	61	36	0	144	410
05:30 PM	21	86	21	0	128	14	8	4	0	26	10	100	14	0	124	48	55	38	0	141	419
05:45 PM	9	88	19	0	116	16	10	4	0	30	10	114	6	0	130	38	55	39	0	132	408
Total	51	340	76	0	467	64	41	22	0	127	33	434	34	0	501	170	230	142	0	542	1637
Grand Total	218	1408	312	3	1941	309	146	112	3	570	117	1599	126	0	1842	459	628	456	2	1545	5898
Apprch %	11.2	72.5	16.1	0.2		54.2	25.6	19.6	0.5		6.4	86.8	6.8	0		29.7	40.6	29.5	0.1		
Total %	3.7	23.9	5.3	0.1	32.9	5.2	2.5	1.9	0.1	9.7	2	27.1	2.1	0	31.2	7.8	10.6	7.7	0	26.2	
CARS	216	1382	307	3	1908	298	144	111	3	556	117	1578	123	0	1818	457	625	451	2	1535	5817
% CARS	99.1	98.2	98.4	100	98.3	96.4	98.6	99.1	100	97.5	100	98.7	97.6	0	98.7	99.6	99.5	98.9	100	99.4	98.6
TRUCKS	1	5	0	0	6	0	1	0	0	1	0	4	3	0	7	2	1	3	0	6	20
% TRUCKS	0.5	0.4	0	0	0.3	0	0.7	0	0	0.2	0	0.3	2.4	0	0.4	0.4	0.2	0.7	0	0.4	0.3
BUSES	1	21	5	0	27	11	1	1	0	13	0	17	0	0	17	0	2	2	0	4	61
% BUSES	0.5	1.5	1.6	0	1.4	3.6	0.7	0.9	0	2.3	0	1.1	0	0	0.9	0	0.3	0.4	0	0.3	1

Weston Rd. at Norfield Rd.
A.M. TRAFFIC VOLUMES (7:00 to 9:00 A.M.)
Weston, CT
prepared by Reliable Traffic Counts, LLC
Weather Clear

ALL VEHICLES
PEAK HOUR
5:00 TO 6:00 P.M.

File Name : 1216-1TH
Site Code : 00000002
Start Date : 9/5/2019
Page No : 2

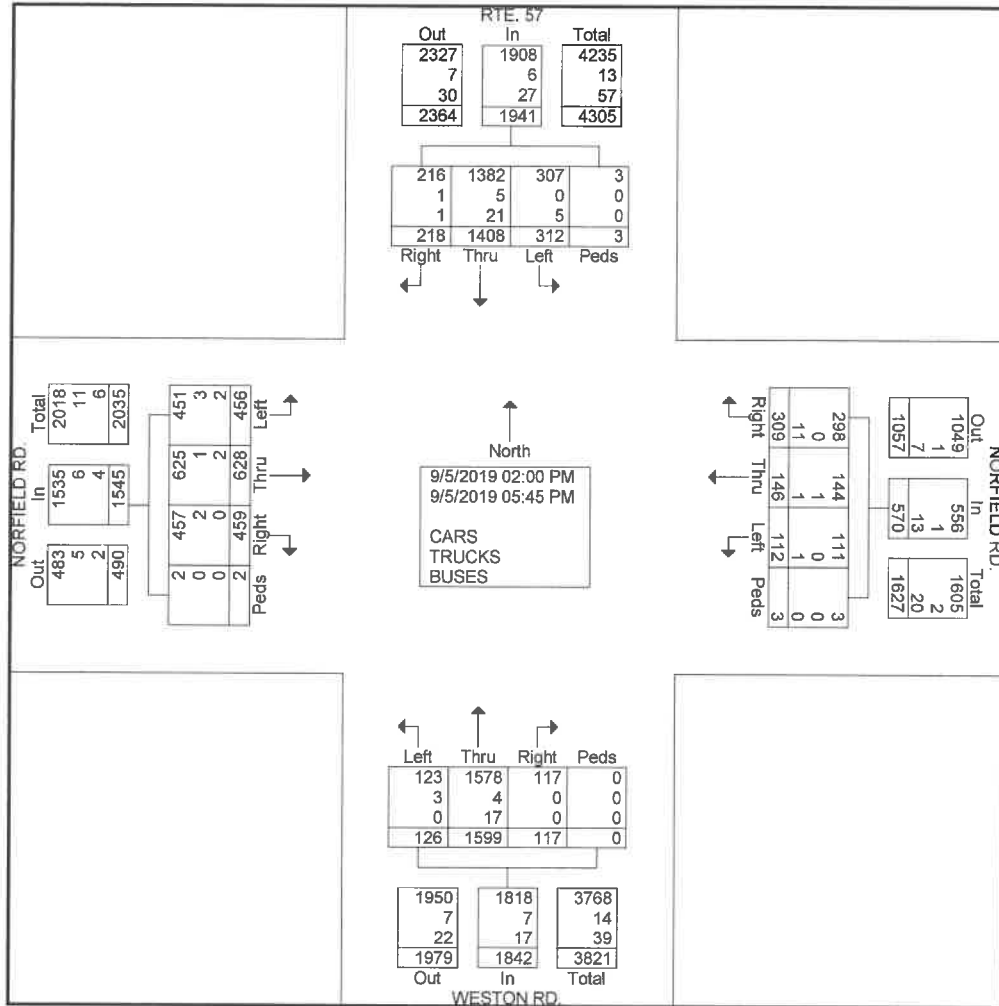

Weston Rd. at Norfield Rd.
A.M. TRAFFIC VOLUMES (7:00 to 9:00 A.M.)
 Weston, CT
 prepared by Reliable Traffic Counts, LLC
 Weather Clear

ALL VEHICLES
 PEAK HOUR
 5:00 TO 6:00 P.M.

File Name : 1216-1TH
 Site Code : 00000002
 Start Date : 9/5/2019
 Page No : 3

Start Time	RTE. 57 SOUTHBOUND					NORFIELD RD. WESTBOUND					WESTON RD. NORTHBOUND					NORFIELD RD. EASTBOUND					Int. Total
	Right	Thru	Left	Peds	App. Total	Right	Thru	Left	Peds	App. Total	Right	Thru	Left	Peds	App. Total	Right	Thru	Left	Peds	App. Total	
Peak Hour Analysis From 05:00 PM to 05:45 PM - Peak 1 of 1																					
Peak Hour for Entire Intersection Begins at 05:00 PM																					
05:00 PM	13	91	17	0	121	18	14	6	0	38	8	98	10	0	116	37	59	29	0	125	400
05:15 PM	8	75	19	0	102	16	9	8	0	33	5	122	4	0	131	47	61	36	0	144	410
05:30 PM	21	86	21	0	128	14	8	4	0	26	10	100	14	0	124	48	55	38	0	141	419
05:45 PM	9	88	19	0	116	16	10	4	0	30	10	114	6	0	130	38	55	39	0	132	408
Total Volume	51	340	76	0	467	64	41	22	0	127	33	434	34	0	501	170	230	142	0	542	1637
% App. Total	10.9	72.8	16.3	0		50.4	32.3	17.3	0		6.6	86.6	6.8	0		31.4	42.4	26.2	0		
PHF	.607	.934	.905	.000	.912	.889	.732	.688	.000	.836	.825	.889	.607	.000	.956	.885	.943	.910	.000	.941	.977

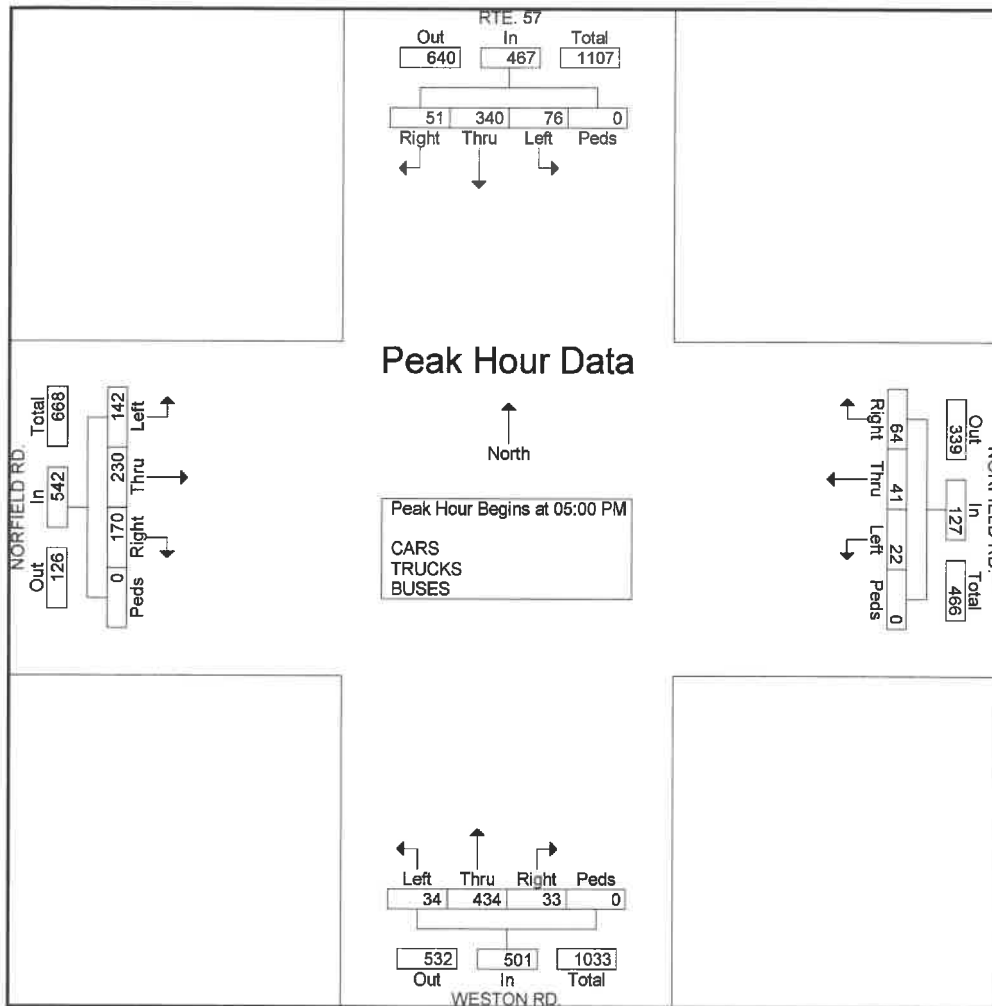

Weston Rd. at Norfield Rd.
A.M. TRAFFIC VOLUMES (7:00 to 9:00 A.M.)
Weston, CT
 prepared by Reliable Traffic Counts, LLC
 Weather Clear

CARS
 PEAK HOUR
 5:00 TO 6:00 P.M.

File Name : 1216-1TH
 Site Code : 00000002
 Start Date : 9/5/2019
 Page No : 4

Groups Printed- CARS

Start Time	RTE. 57 SOUTHBOUND					NORFIELD RD. WESTBOUND					WESTON RD. NORTHBOUND					NORFIELD RD. EASTBOUND					Int. Total
	Right	Thru	Left	Peds	App. Total	Right	Thru	Left	Peds	App. Total	Right	Thru	Left	Peds	App. Total	Right	Thru	Left	Peds	App. Total	
02:00 PM	12	71	16	0	99	21	12	3	0	36	8	83	9	0	100	9	12	18	0	39	274
02:15 PM	13	83	14	0	110	21	9	12	0	42	10	89	11	0	110	12	12	20	0	44	306
02:30 PM	12	122	23	0	157	18	7	4	0	29	4	87	8	0	99	8	5	13	0	26	311
02:45 PM	7	95	21	1	124	27	6	5	0	38	11	82	9	0	102	14	12	20	0	46	310
Total	44	371	74	1	490	87	34	24	0	145	33	341	37	0	411	43	41	71	0	155	1201
03:00 PM	11	86	14	0	111	21	6	10	0	37	5	90	4	0	99	21	17	28	0	66	313
03:15 PM	18	74	24	0	116	13	6	9	0	28	5	114	14	0	133	26	30	13	2	71	348
03:30 PM	13	94	18	0	125	17	13	12	0	42	9	77	9	0	95	32	36	23	0	91	353
03:45 PM	21	67	16	0	104	10	14	7	3	34	10	107	4	0	121	32	48	32	0	112	371
Total	63	321	72	0	456	61	39	38	3	141	29	388	31	0	448	111	131	96	2	340	1385
04:00 PM	18	80	17	1	116	11	5	6	0	22	3	104	6	0	113	42	63	24	0	129	380
04:15 PM	9	84	26	1	120	22	8	7	0	37	10	107	7	0	124	29	69	37	0	135	416
04:30 PM	16	95	22	0	133	28	7	7	0	42	4	105	4	0	113	30	46	41	0	117	405
04:45 PM	15	92	20	0	127	25	10	7	0	42	5	100	4	0	109	32	45	40	0	117	395
Total	58	351	85	2	496	86	30	27	0	143	22	416	21	0	459	133	223	142	0	498	1596
05:00 PM	13	91	17	0	121	18	14	6	0	38	8	98	10	0	116	37	59	29	0	125	400
05:15 PM	8	74	19	0	101	16	9	8	0	33	5	121	4	0	130	47	61	36	0	144	408
05:30 PM	21	86	21	0	128	14	8	4	0	26	10	100	14	0	124	48	55	38	0	141	419
05:45 PM	9	88	19	0	116	16	10	4	0	30	10	114	6	0	130	38	55	39	0	132	408
Total	51	339	76	0	466	64	41	22	0	127	33	433	34	0	500	170	230	142	0	542	1635
Grand Total	216	1382	307	3	1908	298	144	111	3	556	117	1578	123	0	1818	457	625	451	2	1535	5817
Apprch %	11.3	72.4	16.1	0.2		53.6	25.9	20	0.5		6.4	86.8	6.8	0		29.8	40.7	29.4	0.1		
Total %	3.7	23.8	5.3	0.1	32.8	5.1	2.5	1.9	0.1	9.6	2	27.1	2.1	0	31.3	7.9	10.7	7.8	0	26.4	

Weston Rd. at Norfield Rd.
A.M. TRAFFIC VOLUMES (7:00 to 9:00 A.M.)
 Weston, CT
 prepared by Reliable Traffic Counts, LLC
 Weather Clear

TRUCKS
 PEAK HOUR
 5:00 TO 6:00 P.M.

File Name : 1216-1TH
 Site Code : 00000002
 Start Date : 9/5/2019
 Page No : 5

Groups Printed- TRUCKS

Start Time	RTE. 57 SOUTHBOUND					NORFIELD RD. WESTBOUND					WESTON RD. NORTHBOUND					NORFIELD RD. EASTBOUND					Int. Total
	Right	Thru	Left	Peds	App. Total	Right	Thru	Left	Peds	App. Total	Right	Thru	Left	Peds	App. Total	Right	Thru	Left	Peds	App. Total	
02:00 PM	1	0	0	0	1	0	0	0	0	0	0	1	1	0	2	0	0	0	0	0	0
02:15 PM	0	0	0	0	0	0	0	0	0	0	0	1	1	0	2	0	0	0	0	0	0
02:30 PM	0	2	0	0	2	0	0	0	0	0	0	0	0	0	0	0	0	0	0	0	0
02:45 PM	0	1	0	0	1	0	0	0	0	0	0	0	1	0	1	1	1	0	0	2	4
Total	1	3	0	0	4	0	0	0	0	0	0	2	3	0	5	1	1	0	0	2	11
03:00 PM	0	0	0	0	0	0	1	0	0	1	0	0	0	0	0	0	0	0	0	0	1
03:15 PM	0	1	0	0	1	0	0	0	0	0	0	0	0	0	0	0	0	0	0	0	1
03:30 PM	0	0	0	0	0	0	0	0	0	0	0	1	0	0	1	1	0	0	0	1	2
03:45 PM	0	0	0	0	0	0	0	0	0	0	0	1	0	0	1	0	0	0	0	0	1
Total	0	1	0	0	1	0	1	0	0	1	0	2	0	0	2	1	0	0	0	1	5
04:00 PM	0	0	0	0	0	0	0	0	0	0	0	0	0	0	0	0	0	1	0	1	1
04:15 PM	0	0	0	0	0	0	0	0	0	0	0	0	0	0	0	0	0	0	0	0	0
04:30 PM	0	0	0	0	0	0	0	0	0	0	0	0	0	0	0	0	0	2	0	2	2
04:45 PM	0	0	0	0	0	0	0	0	0	0	0	0	0	0	0	0	0	0	0	0	0
Total	0	0	0	0	0	0	0	0	0	0	0	0	0	0	0	0	0	3	0	3	3
05:00 PM	0	0	0	0	0	0	0	0	0	0	0	0	0	0	0	0	0	0	0	0	0
05:15 PM	0	1	0	0	1	0	0	0	0	0	0	0	0	0	0	0	0	0	0	0	1
05:30 PM	0	0	0	0	0	0	0	0	0	0	0	0	0	0	0	0	0	0	0	0	0
05:45 PM	0	0	0	0	0	0	0	0	0	0	0	0	0	0	0	0	0	0	0	0	0
Total	0	1	0	0	1	0	0	0	0	0	0	0	0	0	0	0	0	0	0	0	1
Grand Total	1	5	0	0	6	0	1	0	0	1	0	4	3	0	7	2	1	3	0	6	20
Apprch %	16.7	83.3	0	0		0	100	0	0		0	57.1	42.9	0		33.3	16.7	50	0		
Total %	5	25	0	0	30	0	5	0	0	5	0	20	15	0	35	10	5	15	0	30	

Weston Rd. at Norfield Rd.
A.M. TRAFFIC VOLUMES (7:00 to 9:00 A.M.)
Weston, CT
prepared by Reliable Traffic Counts, LLC
Weather Clear

BUSES
PEAK HOUR
5:00 TO 6:00 P.M.

File Name : 1216-1TH
Site Code : 00000002
Start Date : 9/5/2019
Page No : 6

Groups Printed- BUSES

Start Time	RTE. 57 SOUTHBOUND					NORFIELD RD. WESTBOUND					WESTON RD. NORTHBOUND					NORFIELD RD. EASTBOUND					Int. Total
	Right	Thru	Left	Peds	App. Total	Right	Thru	Left	Peds	App. Total	Right	Thru	Left	Peds	App. Total	Right	Thru	Left	Peds	App. Total	
02:00 PM	0	0	0	0	0	1	0	0	0	1	0	1	0	0	1	0	0	1	0	1	3
02:15 PM	0	1	0	0	1	1	0	0	0	1	0	0	0	0	0	0	0	0	0	0	2
02:30 PM	1	7	0	0	8	0	0	0	0	0	0	0	0	0	0	0	0	0	0	0	8
02:45 PM	0	1	0	0	1	0	0	0	0	0	0	2	0	0	2	0	1	0	0	1	4
Total	1	9	0	0	10	2	0	0	0	2	0	3	0	0	3	0	1	1	0	2	17
03:00 PM	0	2	0	0	2	3	0	0	0	3	0	6	0	0	6	0	0	0	0	0	11
03:15 PM	0	1	0	0	1	0	0	0	0	0	0	1	0	0	1	0	0	0	0	0	2
03:30 PM	0	6	4	0	10	0	1	0	0	1	0	0	0	0	0	0	0	0	0	0	11
03:45 PM	0	0	0	0	0	1	0	1	0	2	0	0	0	0	0	0	1	0	0	1	3
Total	0	9	4	0	13	4	1	1	0	6	0	7	0	0	7	0	1	0	0	1	27
04:00 PM	0	2	1	0	3	2	0	0	0	2	0	4	0	0	4	0	0	0	0	0	9
04:15 PM	0	0	0	0	0	3	0	0	0	3	0	1	0	0	1	0	0	1	0	1	5
04:30 PM	0	1	0	0	1	0	0	0	0	0	0	1	0	0	1	0	0	0	0	0	2
04:45 PM	0	0	0	0	0	0	0	0	0	0	0	0	0	0	0	0	0	0	0	0	0
Total	0	3	1	0	4	5	0	0	0	5	0	6	0	0	6	0	0	1	0	1	16
05:00 PM	0	0	0	0	0	0	0	0	0	0	0	0	0	0	0	0	0	0	0	0	0
05:15 PM	0	0	0	0	0	0	0	0	0	0	0	1	0	0	1	0	0	0	0	0	1
05:30 PM	0	0	0	0	0	0	0	0	0	0	0	0	0	0	0	0	0	0	0	0	0
05:45 PM	0	0	0	0	0	0	0	0	0	0	0	0	0	0	0	0	0	0	0	0	0
Total	0	0	0	0	0	0	0	0	0	0	0	1	0	0	1	0	0	0	0	0	1
Grand Total	1	21	5	0	27	11	1	1	0	13	0	17	0	0	17	0	2	2	0	4	61
Apprch %	3.7	77.8	18.5	0		84.6	7.7	7.7	0		0	100	0	0		0	50	50	0		
Total %	1.6	34.4	8.2	0	44.3	18	1.6	1.6	0	21.3	0	27.9	0	0	27.9	0	3.3	3.3	0	6.6	

Weston Rd. at School Rd.
P.M. TRAFFIC VOLUMES (2:00 to 6:00 P.M.)
Weston, CT
prepared by Reliable Traffic Counts, LLC
Weather Clear

ALL VEHICLES
PEAK HOUR
4:15 TO 5:15 P.M.

File Name : 1216-2TH
Site Code : 00000002
Start Date : 9/5/2019
Page No : 1

Groups Printed- CARS - TRUCKS - BUSES

Start Time	WESTON RD. SOUTHBOUND				SCHOOL RD. WESTBOUND				WESTON RD. NORTHBOUND				EASTBOUND		Int. Total
	Thru	Left	Peds	App. Total	Right	Left	Peds	App. Total	Right	Thru	Peds	App. Total	Peds	App. Total	
02:00 PM	75	7	0	82	5	12	0	17	30	70	0	100	0	0	199
02:15 PM	83	5	0	88	2	14	0	16	55	79	0	134	0	0	238
02:30 PM	88	11	0	99	28	80	0	108	26	83	0	109	0	0	316
02:45 PM	64	9	1	74	11	39	0	50	26	86	0	112	0	0	236
Total	310	32	1	343	46	145	0	191	137	318	0	455	0	0	989
03:00 PM	81	19	0	100	1	30	0	31	42	101	0	143	0	0	274
03:15 PM	65	6	6	77	31	53	0	84	18	103	0	121	0	0	282
03:30 PM	74	1	0	75	27	45	0	72	8	98	0	106	0	0	253
03:45 PM	59	5	0	64	8	36	3	47	15	131	0	146	0	0	257
Total	279	31	6	316	67	164	3	234	83	433	0	516	0	0	1066
04:00 PM	73	6	0	79	6	32	0	38	23	116	0	139	0	0	256
04:15 PM	75	8	0	83	11	27	0	38	25	108	0	133	0	0	254
04:30 PM	76	5	0	81	11	40	0	51	28	130	0	158	0	0	290
04:45 PM	82	5	0	87	10	35	0	45	25	134	0	159	0	0	291
Total	306	24	0	330	38	134	0	172	101	488	0	589	0	0	1091
05:00 PM	98	2	0	100	3	24	0	27	24	134	0	158	0	0	285
05:15 PM	65	5	0	70	1	27	0	28	20	135	0	155	0	0	253
05:30 PM	98	3	0	101	4	22	0	26	21	149	0	170	0	0	297
05:45 PM	99	7	0	106	4	5	0	9	23	117	0	140	0	0	255
Total	360	17	0	377	12	78	0	90	88	535	0	623	0	0	1090
Grand Total	1255	104	7	1366	163	521	3	687	409	1774	0	2183	0	0	4236
Apprch %	91.9	7.6	0.5		23.7	75.8	0.4		18.7	81.3	0		0		
Total %	29.6	2.5	0.2	32.2	3.8	12.3	0.1	16.2	9.7	41.9	0	51.5	0	0	
CARS	1236	93	7	1336	157	504	3	664	359	1766	0	2125	0	0	4125
% CARS	98.5	89.4	100	97.8	96.3	96.7	100	96.7	87.8	99.5	0	97.3	0	0	97.4
TRUCKS	5	0	0	5	0	0	0	0	0	7	0	7	0	0	12
% TRUCKS	0.4	0	0	0.4	0	0	0	0	0	0.4	0	0.3	0	0	0.3
BUSES	14	11	0	25	6	17	0	23	50	1	0	51	0	0	99
% BUSES	1.1	10.6	0	1.8	3.7	3.3	0	3.3	12.2	0.1	0	2.3	0	0	2.3

Weston Rd. at School Rd.
P.M. TRAFFIC VOLUMES (2:00 to 6:00 P.M.)
Weston, CT
prepared by Reliable Traffic Counts, LLC
Weather Clear

ALL VEHICLES
PEAK HOUR
4:15 TO 5:15 P.M.

File Name : 1216-2TH
Site Code : 00000002
Start Date : 9/5/2019
Page No : 2

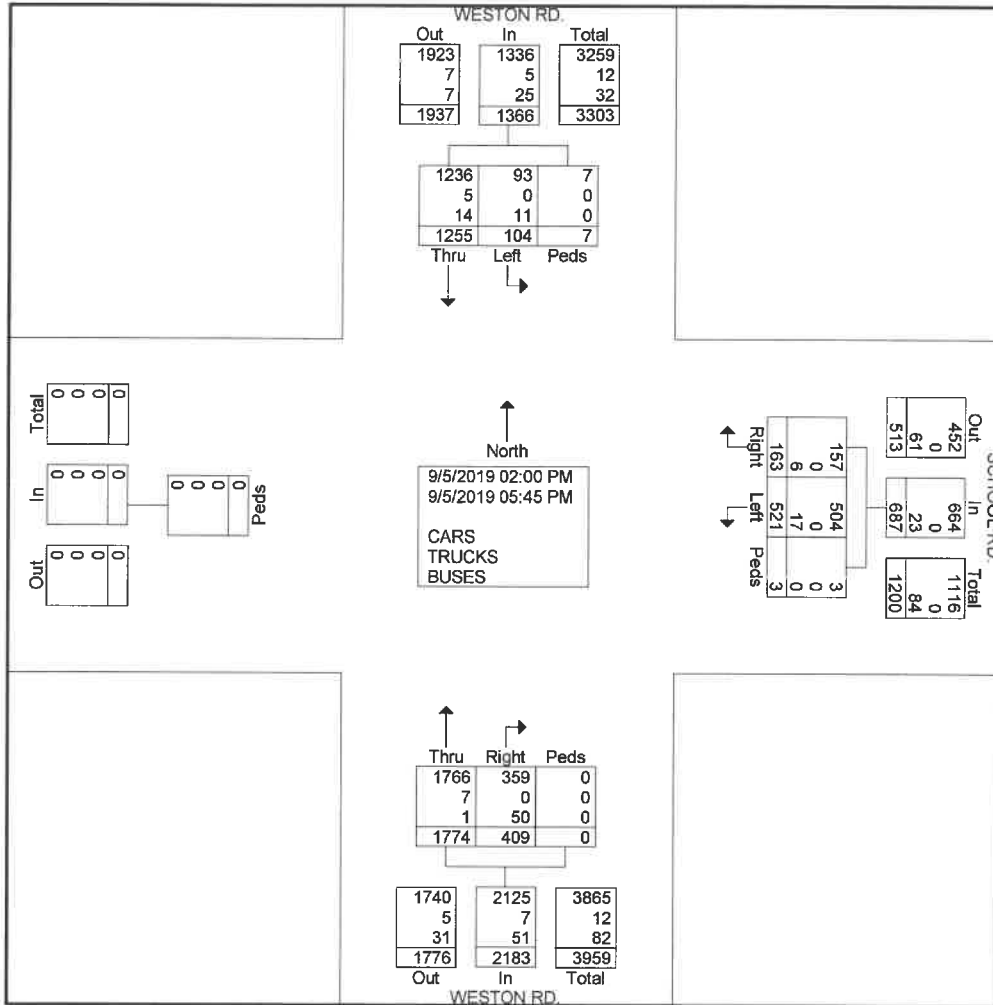

Weston Rd. at School Rd.
P.M. TRAFFIC VOLUMES (2:00 to 6:00 P.M.)
Weston, CT
prepared by Reliable Traffic Counts, LLC
Weather Clear

ALL VEHICLES
PEAK HOUR
4:15 TO 5:15 P.M.

File Name : 1216-2TH
Site Code : 00000002
Start Date : 9/5/2019
Page No : 3

Start Time	WESTON RD. SOUTHBOUND				SCHOOL RD. WESTBOUND				WESTON RD. NORTHBOUND				EASTBOUND		Int. Total
	Thru	Left	Peds	App. Total	Right	Left	Peds	App. Total	Right	Thru	Peds	App. Total	Peds	App. Total	
Peak Hour Analysis From 04:15 PM to 05:00 PM - Peak 1 of 1															
Peak Hour for Entire Intersection Begins at 04:15 PM															
04:15 PM	75	8	0	83	11	27	0	38	25	108	0	133	0	0	254
04:30 PM	76	5	0	81	11	40	0	51	28	130	0	158	0	0	290
04:45 PM	82	5	0	87	10	35	0	45	25	134	0	159	0	0	291
05:00 PM	98	2	0	100	3	24	0	27	24	134	0	158	0	0	285
Total Volume	331	20	0	351	35	126	0	161	102	506	0	608	0	0	1120
% App. Total	94.3	5.7	0		21.7	78.3	0		16.8	83.2	0		0		
PHF	.844	.625	.000	.878	.795	.788	.000	.789	.911	.944	.000	.956	.000	.000	.962

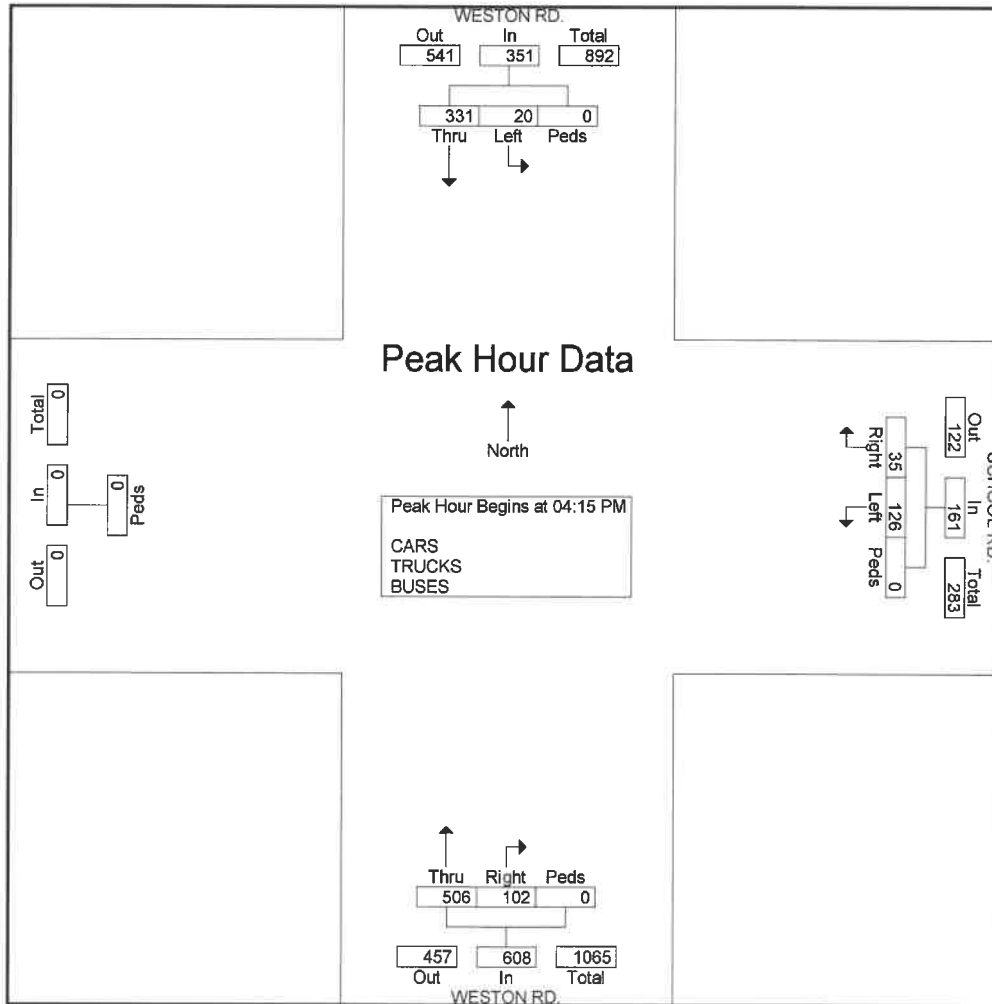

Weston Rd. at School Rd.
P.M. TRAFFIC VOLUMES (2:00 to 6:00 P.M.)
Weston, CT
prepared by Reliable Traffic Counts, LLC
Weather Clear

CARS
PEAK HOUR
4:15 TO 5:15 P.M.

File Name : 1216-2TH
Site Code : 00000002
Start Date : 9/5/2019
Page No : 4

Groups Printed- CARS

Start Time	WESTON RD. SOUTHBOUND				SCHOOL RD. WESTBOUND				WESTON RD. NORTHBOUND				EASTBOUND		
	Thru	Left	Peds	App. Total	Right	Left	Peds	App. Total	Right	Thru	Peds	App. Total	Peds	App. Total	Int. Total
02:00 PM	74	7	0	81	5	12	0	17	27	69	0	96	0	0	194
02:15 PM	83	5	0	88	2	14	0	16	38	78	0	116	0	0	220
02:30 PM	79	11	0	90	28	78	0	106	26	83	0	109	0	0	305
02:45 PM	63	9	1	73	11	39	0	50	25	86	0	111	0	0	234
Total	299	32	1	332	46	143	0	189	116	316	0	432	0	0	953
03:00 PM	77	15	0	92	1	28	0	29	34	101	0	135	0	0	256
03:15 PM	63	5	6	74	31	53	0	84	15	103	0	118	0	0	276
03:30 PM	74	1	0	75	21	34	0	55	8	98	0	106	0	0	236
03:45 PM	59	4	0	63	8	36	3	47	12	130	0	142	0	0	252
Total	273	25	6	304	61	151	3	215	69	432	0	501	0	0	1020
04:00 PM	73	2	0	75	6	30	0	36	18	115	0	133	0	0	244
04:15 PM	75	7	0	82	11	27	0	38	18	108	0	126	0	0	246
04:30 PM	74	5	0	79	11	40	0	51	25	128	0	153	0	0	283
04:45 PM	82	5	0	87	10	35	0	45	25	134	0	159	0	0	291
Total	304	19	0	323	38	132	0	170	86	485	0	571	0	0	1064
05:00 PM	98	2	0	100	3	24	0	27	24	134	0	158	0	0	285
05:15 PM	65	5	0	70	1	27	0	28	20	134	0	154	0	0	252
05:30 PM	98	3	0	101	4	22	0	26	21	148	0	169	0	0	296
05:45 PM	99	7	0	106	4	5	0	9	23	117	0	140	0	0	255
Total	360	17	0	377	12	78	0	90	88	533	0	621	0	0	1088
Grand Total	1236	93	7	1336	157	504	3	664	359	1766	0	2125	0	0	4125
Apprch %	92.5	7	0.5		23.6	75.9	0.5		16.9	83.1	0		0		
Total %	30	2.3	0.2	32.4	3.8	12.2	0.1	16.1	8.7	42.8	0	51.5	0	0	

Weston Rd. at School Rd.
P.M. TRAFFIC VOLUMES (2:00 to 6:00 P.M.)
Weston, CT
prepared by Reliable Traffic Counts, LLC
Weather Clear

TRUCKS
PEAK HOUR
4:15 TO 5:15 P.M.

File Name : 1216-2TH
Site Code : 00000002
Start Date : 9/5/2019
Page No : 5

Groups Printed- TRUCKS

Start Time	WESTON RD. SOUTHBOUND				SCHOOL RD. WESTBOUND				WESTON RD. NORTHBOUND				EASTBOUND		Int. Total
	Thru	Left	Peds	App. Total	Right	Left	Peds	App. Total	Right	Thru	Peds	App. Total	Peds	App. Total	
02:00 PM	1	0	0	1	0	0	0	0	0	1	0	1	0	0	2
02:15 PM	0	0	0	0	0	0	0	0	0	1	0	1	0	0	1
02:30 PM	2	0	0	2	0	0	0	0	0	0	0	0	0	0	2
02:45 PM	1	0	0	1	0	0	0	0	0	0	0	0	0	0	1
Total	4	0	0	4	0	0	0	0	0	2	0	2	0	0	6
03:00 PM	0	0	0	0	0	0	0	0	0	0	0	0	0	0	0
03:15 PM	1	0	0	1	0	0	0	0	0	0	0	0	0	0	1
03:30 PM	0	0	0	0	0	0	0	0	0	0	0	0	0	0	0
03:45 PM	0	0	0	0	0	0	0	0	0	1	0	1	0	0	1
Total	1	0	0	1	0	0	0	0	0	1	0	1	0	0	2
04:00 PM	0	0	0	0	0	0	0	0	0	1	0	1	0	0	1
04:15 PM	0	0	0	0	0	0	0	0	0	0	0	0	0	0	0
04:30 PM	0	0	0	0	0	0	0	0	0	2	0	2	0	0	2
04:45 PM	0	0	0	0	0	0	0	0	0	0	0	0	0	0	0
Total	0	0	0	0	0	0	0	0	0	3	0	3	0	0	3
05:00 PM	0	0	0	0	0	0	0	0	0	0	0	0	0	0	0
05:15 PM	0	0	0	0	0	0	0	0	0	0	0	0	0	0	0
05:30 PM	0	0	0	0	0	0	0	0	0	1	0	1	0	0	1
05:45 PM	0	0	0	0	0	0	0	0	0	0	0	0	0	0	0
Total	0	0	0	0	0	0	0	0	0	1	0	1	0	0	1
Grand Total	5	0	0	5	0	0	0	0	0	7	0	7	0	0	12
Apprch %	100	0	0		0	0	0		0	100	0		0		
Total %	41.7	0	0	41.7	0	0	0	0	0	58.3	0	58.3	0	0	

Weston Rd. at School Rd.
P.M. TRAFFIC VOLUMES (2:00 to 6:00 P.M.)
Weston, CT
prepared by Reliable Traffic Counts, LLC
Weather Clear

BUSES
PEAK HOUR
4:15 TO 5:15 P.M.

File Name : 1216-2TH
Site Code : 00000002
Start Date : 9/5/2019
Page No : 6

Groups Printed- BUSES

Start Time	WESTON RD. SOUTHBOUND				SCHOOL RD. WESTBOUND				WESTON RD. NORTHBOUND				EASTBOUND		Int. Total
	Thru	Left	Peds	App. Total	Right	Left	Peds	App. Total	Right	Thru	Peds	App. Total	Peds	App. Total	
02:00 PM	0	0	0	0	0	0	0	0	3	0	0	3	0	0	3
02:15 PM	0	0	0	0	0	0	0	0	17	0	0	17	0	0	17
02:30 PM	7	0	0	7	0	2	0	2	0	0	0	0	0	0	9
02:45 PM	0	0	0	0	0	0	0	0	1	0	0	1	0	0	1
Total	7	0	0	7	0	2	0	2	21	0	0	21	0	0	30
03:00 PM	4	4	0	8	0	2	0	2	8	0	0	8	0	0	18
03:15 PM	1	1	0	2	0	0	0	0	3	0	0	3	0	0	5
03:30 PM	0	0	0	0	6	11	0	17	0	0	0	0	0	0	17
03:45 PM	0	1	0	1	0	0	0	0	3	0	0	3	0	0	4
Total	5	6	0	11	6	13	0	19	14	0	0	14	0	0	44
04:00 PM	0	4	0	4	0	2	0	2	5	0	0	5	0	0	11
04:15 PM	0	1	0	1	0	0	0	0	7	0	0	7	0	0	8
04:30 PM	2	0	0	2	0	0	0	0	3	0	0	3	0	0	5
04:45 PM	0	0	0	0	0	0	0	0	0	0	0	0	0	0	0
Total	2	5	0	7	0	2	0	2	15	0	0	15	0	0	24
05:00 PM	0	0	0	0	0	0	0	0	0	0	0	0	0	0	0
05:15 PM	0	0	0	0	0	0	0	0	0	1	0	1	0	0	1
05:30 PM	0	0	0	0	0	0	0	0	0	0	0	0	0	0	0
05:45 PM	0	0	0	0	0	0	0	0	0	0	0	0	0	0	0
Total	0	0	0	0	0	0	0	0	0	1	0	1	0	0	1
Grand Total	14	11	0	25	6	17	0	23	50	1	0	51	0	0	99
Apprch %	56	44	0		26.1	73.9	0		98	2	0		0		
Total %	14.1	11.1	0	25.3	6.1	17.2	0	23.2	50.5	1	0	51.5	0	0	

LEVEL OF SERVICE FOR SIGNALIZED INTERSECTIONS (MOTORIZED VEHICLE MODE)

Level of service for signalized intersections is defined in terms of control delay, which is a measure of driver discomfort, frustration, fuel consumption, and increased travel time. The delay experienced by a motorist is made up of a number of factors that relate to control, geometrics, traffic, and incidents. Total delay is the difference between the travel time actually experienced and the reference travel time that would result during base conditions: in the absence of traffic control, geometric delay, any incidents, and any other vehicles. Specifically, LOS criteria for traffic signals are stated in terms of the average control delay per vehicle, typically for a 15-min analysis period. Delay is a complex measure and depends on a number of variables, including the quality of progression, the cycle length, the green ratio, and the v/c ratio for the lane group. The criteria are given below.

LEVEL-OF SERVICE CRITERIA FOR SIGNALIZED INTERSECTIONS MOTORIZED VEHICLE MODE		
LOS By Volume-to-Capacity Ratio¹		CONTROL DELAY (s/veh)
v/c ≤ 1.0	v/c > 1.0	
A	F	≤ 10
B	F	> 10 AND ≤ 20
C	F	> 20 AND ≤ 35
D	F	> 35 AND ≤ 55
E	F	> 55 AND ≤ 80
F	F	> 80

¹ For approach-based and intersection-wide assessments, LOS is defined solely by control delay.

Specific descriptions of each LOS for signalized intersections are provided below:

Level of Service A describes operations with a control delay of 10 s/veh and 20 s/veh and a volume-to-capacity ratio no greater than 1.0. This level is typically assigned when the volume-to-capacity ratio is low and either progression is exceptionally favorable or the cycle length is very short. If LOS A is the result of favorable progression, most vehicles arrive during the green indication and travel through the intersection without stopping.

Level of Service B describes operations with control delay between 10 and 20 s/veh and a volume-to-capacity ratio no greater than 1.0. This level is typically assigned when the volume-to-capacity ratio is low and either progression is highly favorable or the cycle length is short. More vehicles stop than with LOS A.

Level of Service C describes operations with control delay between 20 and 35 s/veh and a volume-to-capacity ratio no greater than 1.0. This level is typically assigned when progression is favorable or the cycle length is moderate. Individual *cycle failures* (i.e., one or more queued vehicles are not able to depart as a result of insufficient capacity during the cycle) may begin to appear at this level. The number of vehicles stopping is significant, although many vehicles still pass through the intersection without stopping.

Level of Service D describes operations with control delay between 35 and 55 s/veh and a volume-to-capacity ratio no greater than 1.0. This level is typically assigned when the volume-to-capacity ratio is high and either progression is ineffective or the cycle length is long. Many vehicles stop and individual cycle failures are noticeable.

Level of Service E describes operations with control delay between 55 and 80 s/veh and a volume-to-capacity ratio no greater than 1.0. This level is typically assigned when the volume-to-capacity ratio is high, progression is unfavorable, and the cycle length is long. Individual cycle failures are frequent.

Level of Service F describes operations with control delay exceeding 80 s/veh or a volume-to-capacity ratio greater than 1.0. This level is typically assigned when the volume-to-capacity ratio is very high, progression is very poor, and the cycle length is long. Most cycles fail to clear the queue.

Reference: Highway Capacity Manual 6, Transportation Research Board, 2016.

LEVEL OF SERVICE

FOR TWO-WAY

STOP SIGN CONTROLLED INTERSECTIONS

The level of service for a TWSC (two-way stop controlled) intersection is determined by the computed or measured control delay and is defined for each minor movement. Level of service is not defined for the intersection as a whole. Control delay includes initial deceleration delay, queue move-up time, stopped delay, and final acceleration delay. LOS criteria are given in the Table. LOS criteria are given below:

LEVEL-OF SERVICE CRITERIA FOR AWSC INTERSECTIONS	
LOS¹	CONTROL DELAY (s/veh)
A	≤ 10
B	$> 10 \text{ AND } \leq 15$
C	$> 15 \text{ AND } \leq 25$
D	$> 25 \text{ AND } \leq 35$
E	$> 35 \text{ AND } \leq 50$
F	> 50

Note: LOS criteria apply to each lane on a given approach and to each approach on the minor street.
 LOS is not calculated for major-street approaches or for the intersection as a whole.
 LOS F is assigned to a movement if the volume-to-capacity ratio exceeds 1.0, regardless of the control delay

Reference: Highway Capacity Manual Version 6.0, Transportation Research Board, 2016.

Weston Town Center
1: Weston Rd (Rt 57) & Norfield Rd

Existing
Timing Plan: AM Peak



Lane Group	EBL	EBT	EBR	WBL	WBT	WBR	NBL	NBT	NBR	SBL	SBT	SBR
Lane Configurations		↕			↕	↕		↕			↕	
Traffic Volume (vph)	54	24	28	42	242	136	92	299	22	49	468	96
Future Volume (vph)	54	24	28	42	242	136	92	299	22	49	468	96
Ideal Flow (vphpl)	1900	1900	1900	1900	1900	1900	1900	1900	1900	1900	1900	1900
Storage Length (ft)	0		0	0		50	0		0	0		0
Storage Lanes	0		0	0		1	0		0	0		0
Taper Length (ft)	25			25			25			25		
Lane Util. Factor	1.00	1.00	1.00	1.00	1.00	1.00	1.00	1.00	1.00	1.00	1.00	1.00
Frt		0.964				0.850		0.993			0.979	
Flt Protected		0.975			0.993			0.989			0.996	
Satd. Flow (prot)	0	1751	0	0	1850	1583	0	1829	0	0	1816	0
Flt Permitted		0.537			0.937			0.730			0.948	
Satd. Flow (perm)	0	964	0	0	1745	1583	0	1350	0	0	1729	0
Right Turn on Red			Yes			Yes			Yes			No
Satd. Flow (RTOR)		20				139		3				
Link Speed (mph)		25			25			35			35	
Link Distance (ft)		324			356			661			1123	
Travel Time (s)		8.8			9.7			12.9			21.9	
Peak Hour Factor	0.93	0.93	0.93	0.93	0.93	0.93	0.93	0.93	0.93	0.93	0.93	0.93
Adj. Flow (vph)	58	26	30	45	260	146	99	322	24	53	503	103
Shared Lane Traffic (%)												
Lane Group Flow (vph)	0	114	0	0	305	146	0	445	0	0	659	0
Number of Detectors	1	2		1	2	1	1	2		1	2	
Detector Template	Left	Thru		Left	Thru	Right	Left	Thru		Left	Thru	
Leading Detector (ft)	20	100		20	100	20	20	100		20	100	
Trailing Detector (ft)	0	0		0	0	0	0	0		0	0	
Detector 1 Position(ft)	0	0		0	0	0	0	0		0	0	
Detector 1 Size(ft)	20	6		20	6	20	20	6		20	6	
Detector 1 Type	Cl+Ex	Cl+Ex		Cl+Ex	Cl+Ex	Cl+Ex	Cl+Ex	Cl+Ex		Cl+Ex	Cl+Ex	
Detector 1 Channel												
Detector 1 Extend (s)	0.0	0.0		0.0	0.0	0.0	0.0	0.0		0.0	0.0	
Detector 1 Queue (s)	0.0	0.0		0.0	0.0	0.0	0.0	0.0		0.0	0.0	
Detector 1 Delay (s)	0.0	0.0		0.0	0.0	0.0	0.0	0.0		0.0	0.0	
Detector 2 Position(ft)		94			94			94			94	
Detector 2 Size(ft)		6			6			6			6	
Detector 2 Type		Cl+Ex			Cl+Ex			Cl+Ex			Cl+Ex	
Detector 2 Channel												
Detector 2 Extend (s)		0.0			0.0			0.0			0.0	
Turn Type	D.P+P	NA		Perm	NA	Perm	Perm	NA		D.P+P	NA	
Protected Phases	4	4 5			5			2		1	1 2	
Permitted Phases	5			5		5	2			2		
Detector Phase	4	4 5		5	5	5	2	2		1	1 2	
Switch Phase												
Minimum Initial (s)	5.0			7.0	7.0	7.0	15.0	15.0		5.0		
Minimum Split (s)	9.0			21.7	21.7	21.7	21.7	21.7		9.0		
Total Split (s)	9.0			25.2	25.2	25.2	39.7	39.7		18.0		
Total Split (%)	9.8%			27.4%	27.4%	27.4%	43.2%	43.2%		19.6%		
Maximum Green (s)	5.0			20.7	20.7	20.7	33.0	33.0		14.0		
Yellow Time (s)	3.0			3.5	3.5	3.5	4.2	4.2		3.0		

Weston Town Center
1: Weston Rd (Rt 57) & Norfield Rd

Existing
Timing Plan: AM Peak



Lane Group	EBL	EBT	EBR	WBL	WBT	WBR	NBL	NBT	NBR	SBL	SBT	SBR
All-Red Time (s)	1.0			1.0	1.0	1.0	2.5	2.5		1.0		
Lost Time Adjust (s)					0.0	0.0		0.0				
Total Lost Time (s)					4.5	4.5		6.7				
Lead/Lag							Lag	Lag		Lead		
Lead-Lag Optimize?							Yes	Yes		Yes		
Vehicle Extension (s)	3.0			3.0	3.0	3.0	2.5	2.5		2.5		
Recall Mode	None			None	None	None	Min	Min		Min		
Walk Time (s)				11.0	11.0	11.0						
Flash Dont Walk (s)				6.2	6.2	6.2						
Pedestrian Calls (#/hr)				0	0	0						
Act Effct Green (s)		22.9			18.6	18.6		31.4			48.3	
Actuated g/C Ratio		0.26			0.22	0.22		0.36			0.56	
v/c Ratio		0.36			0.81	0.32		0.91			0.67	
Control Delay		22.4			51.3	8.4		51.8			17.1	
Queue Delay		0.0			0.0	0.0		0.0			0.0	
Total Delay		22.4			51.3	8.4		51.8			17.1	
LOS		C			D	A		D			B	
Approach Delay		22.4			37.4			51.8			17.1	
Approach LOS		C			D			D			B	
Queue Length 50th (ft)		38			167	3		242			232	
Queue Length 95th (ft)		79			#294	50		#433			343	
Internal Link Dist (ft)		244			276			581			1043	
Turn Bay Length (ft)						50						
Base Capacity (vph)		342			424	490		524			1023	
Starvation Cap Reductn		0			0	0		0			0	
Spillback Cap Reductn		0			0	0		0			0	
Storage Cap Reductn		0			0	0		0			0	
Reduced v/c Ratio		0.33			0.72	0.30		0.85			0.64	

Intersection Summary

Area Type: Other
 Cycle Length: 91.9
 Actuated Cycle Length: 86.5
 Natural Cycle: 90
 Control Type: Actuated-Uncoordinated
 Maximum v/c Ratio: 0.91
 Intersection Signal Delay: 32.2
 Intersection LOS: C
 Intersection Capacity Utilization 78.0%
 ICU Level of Service D
 Analysis Period (min) 15
 # 95th percentile volume exceeds capacity, queue may be longer.
 Queue shown is maximum after two cycles.

Splits and Phases: 1: Weston Rd (Rt 57) & Norfield Rd



Weston Town Center
2: Weston Rd (Rt 57) & School Rd

Existing
Timing Plan: AM Peak



Lane Group	WBL	WBR	NBT	NBR	SBL	SBT
Lane Configurations						
Traffic Volume (vph)	120	49	205	241	82	507
Future Volume (vph)	120	49	205	241	82	507
Ideal Flow (vphpl)	1900	1900	1900	1900	1900	1900
Lane Util. Factor	1.00	1.00	1.00	1.00	1.00	1.00
Frt		0.850	0.927			
Flt Protected	0.950					0.993
Satd. Flow (prot)	1770	1583	1727	0	0	1850
Flt Permitted	0.950					0.874
Satd. Flow (perm)	1770	1583	1727	0	0	1628
Right Turn on Red		Yes		Yes		
Satd. Flow (RTOR)		59	97			
Link Speed (mph)	25		35			35
Link Distance (ft)	151		1123			305
Travel Time (s)	4.1		21.9			5.9
Peak Hour Factor	0.83	0.83	0.83	0.83	0.83	0.83
Adj. Flow (vph)	145	59	247	290	99	611
Shared Lane Traffic (%)						
Lane Group Flow (vph)	145	59	537	0	0	710
Number of Detectors	1	1	2		1	2
Detector Template	Left	Right	Thru		Left	Thru
Leading Detector (ft)	20	20	100		20	100
Trailing Detector (ft)	0	0	0		0	0
Detector 1 Position(ft)	0	0	0		0	0
Detector 1 Size(ft)	20	20	6		20	6
Detector 1 Type	Cl+Ex	Cl+Ex	Cl+Ex		Cl+Ex	Cl+Ex
Detector 1 Channel						
Detector 1 Extend (s)	0.0	0.0	0.0		0.0	0.0
Detector 1 Queue (s)	0.0	0.0	0.0		0.0	0.0
Detector 1 Delay (s)	0.0	0.0	0.0		0.0	0.0
Detector 2 Position(ft)			94			94
Detector 2 Size(ft)			6			6
Detector 2 Type			Cl+Ex			Cl+Ex
Detector 2 Channel						
Detector 2 Extend (s)			0.0			0.0
Turn Type	Prot	Perm	NA		D.P+P	NA
Protected Phases	4		2		1	1 2
Permitted Phases		4			2	
Detector Phase	4	4	2		1	1 2
Switch Phase						
Minimum Initial (s)	7.0	7.0	15.0		7.0	
Minimum Split (s)	20.0	20.0	21.7		10.1	
Total Split (s)	19.0	19.0	46.7		18.1	
Total Split (%)	22.7%	22.7%	55.7%		21.6%	
Maximum Green (s)	14.0	14.0	40.0		15.0	
Yellow Time (s)	3.0	3.0	4.2		3.0	
All-Red Time (s)	2.0	2.0	2.5		0.1	
Lost Time Adjust (s)	0.0	0.0	0.0			
Total Lost Time (s)	5.0	5.0	6.7			

Weston Town Center
 2: Weston Rd (Rt 57) & School Rd

Existing
 Timing Plan: AM Peak



Lane Group	WBL	WBR	NBT	NBR	SBL	SBT
Lead/Lag			Lag		Lead	
Lead-Lag Optimize?			Yes		Yes	
Vehicle Extension (s)	2.0	2.0	2.5		3.0	
Recall Mode	None	None	Min		Max	
Walk Time (s)	9.0	9.0				
Flash Dont Walk (s)	6.0	6.0				
Pedestrian Calls (#/hr)	0	0				
Act Effct Green (s)	10.2	10.2	26.0			45.8
Actuated g/C Ratio	0.16	0.16	0.41			0.71
v/c Ratio	0.52	0.20	0.71			0.58
Control Delay	35.8	10.6	19.1			6.5
Queue Delay	0.0	0.0	0.0			0.0
Total Delay	35.8	10.6	19.1			6.5
LOS	D	B	B			A
Approach Delay	28.5		19.1			6.5
Approach LOS	C		B			A
Queue Length 50th (ft)	55	0	143			95
Queue Length 95th (ft)	116	27	228			168
Internal Link Dist (ft)	71		1043			225
Turn Bay Length (ft)						
Base Capacity (vph)	412	414	1181			1466
Starvation Cap Reductn	0	0	0			0
Spillback Cap Reductn	0	0	0			0
Storage Cap Reductn	0	0	0			0
Reduced v/c Ratio	0.35	0.14	0.45			0.48

Intersection Summary

Area Type:	Other
Cycle Length:	83.8
Actuated Cycle Length:	64.1
Natural Cycle:	70
Control Type:	Actuated-Uncoordinated
Maximum v/c Ratio:	0.71
Intersection Signal Delay:	14.3
Intersection LOS:	B
Intersection Capacity Utilization:	76.5%
ICU Level of Service:	D
Analysis Period (min):	15

Splits and Phases: 2: Weston Rd (Rt 57) & School Rd



Weston Town Center
1: Weston Rd (Rt 57) & Norfield Rd

Existing
Timing Plan: PM Peak



Lane Group	EBL	EBT	EBR	WBL	WBT	WBR	NBL	NBT	NBR	SBL	SBT	SBR
Lane Configurations		↕			↕	↕		↕			↕	
Traffic Volume (vph)	143	220	164	25	41	73	32	420	28	77	344	57
Future Volume (vph)	143	220	164	25	41	73	32	420	28	77	344	57
Ideal Flow (vphpl)	1900	1900	1900	1900	1900	1900	1900	1900	1900	1900	1900	1900
Storage Length (ft)	0		0	0		50	0		0	0		0
Storage Lanes	0		0	0		1	0		0	0		0
Taper Length (ft)	25			25			25			25		
Lane Util. Factor	1.00	1.00	1.00	1.00	1.00	1.00	1.00	1.00	1.00	1.00	1.00	1.00
Frt		0.958				0.850		0.992			0.984	
Flt Protected		0.987			0.981			0.997			0.992	
Satd. Flow (prot)	0	1761	0	0	1827	1583	0	1842	0	0	1818	0
Flt Permitted		0.885			0.775			0.940			0.850	
Satd. Flow (perm)	0	1579	0	0	1444	1583	0	1737	0	0	1558	0
Right Turn on Red			Yes			Yes			Yes			No
Satd. Flow (RTOR)		25				139		4				
Link Speed (mph)		25			25			35			35	
Link Distance (ft)		324			356			661			1123	
Travel Time (s)		8.8			9.7			12.9			21.9	
Peak Hour Factor	0.97	0.97	0.97	0.97	0.97	0.97	0.97	0.97	0.97	0.97	0.97	0.97
Adj. Flow (vph)	147	227	169	26	42	75	33	433	29	79	355	59
Shared Lane Traffic (%)												
Lane Group Flow (vph)	0	543	0	0	68	75	0	495	0	0	493	0
Number of Detectors	1	2		1	2	1	1	2		1	2	
Detector Template	Left	Thru		Left	Thru	Right	Left	Thru		Left	Thru	
Leading Detector (ft)	20	100		20	100	20	20	100		20	100	
Trailing Detector (ft)	0	0		0	0	0	0	0		0	0	
Detector 1 Position(ft)	0	0		0	0	0	0	0		0	0	
Detector 1 Size(ft)	20	6		20	6	20	20	6		20	6	
Detector 1 Type	Cl+Ex	Cl+Ex		Cl+Ex	Cl+Ex	Cl+Ex	Cl+Ex	Cl+Ex		Cl+Ex	Cl+Ex	
Detector 1 Channel												
Detector 1 Extend (s)	0.0	0.0		0.0	0.0	0.0	0.0	0.0		0.0	0.0	
Detector 1 Queue (s)	0.0	0.0		0.0	0.0	0.0	0.0	0.0		0.0	0.0	
Detector 1 Delay (s)	0.0	0.0		0.0	0.0	0.0	0.0	0.0		0.0	0.0	
Detector 2 Position(ft)		94			94			94			94	
Detector 2 Size(ft)		6			6			6			6	
Detector 2 Type		Cl+Ex			Cl+Ex			Cl+Ex			Cl+Ex	
Detector 2 Channel												
Detector 2 Extend (s)		0.0			0.0			0.0			0.0	
Turn Type	D.P+P	NA		Perm	NA	Perm	Perm	NA		D.P+P	NA	
Protected Phases	4	4 5			5			2		1	1 2	
Permitted Phases	5			5		5	2			2		
Detector Phase	4	4 5		5	5	5	2	2		1	1 2	
Switch Phase												
Minimum Initial (s)	5.0			7.0	7.0	7.0	15.0	15.0		5.0		
Minimum Split (s)	9.0			21.7	21.7	21.7	21.7	21.7		9.0		
Total Split (s)	9.0			25.2	25.2	25.2	39.7	39.7		18.0		
Total Split (%)	9.8%			27.4%	27.4%	27.4%	43.2%	43.2%		19.6%		
Maximum Green (s)	5.0			20.7	20.7	20.7	33.0	33.0		14.0		
Yellow Time (s)	3.0			3.5	3.5	3.5	4.2	4.2		3.0		

Weston Town Center
1: Weston Rd (Rt 57) & Norfield Rd

Existing
Timing Plan: PM Peak



Lane Group	EBL	EBT	EBR	WBL	WBT	WBR	NBL	NBT	NBR	SBL	SBT	SBR
All-Red Time (s)	1.0			1.0	1.0	1.0	2.5	2.5		1.0		
Lost Time Adjust (s)					0.0	0.0		0.0				
Total Lost Time (s)					4.5	4.5		6.7				
Lead/Lag							Lag	Lag		Lead		
Lead-Lag Optimize?							Yes	Yes		Yes		
Vehicle Extension (s)	3.0			3.0	3.0	3.0	2.5	2.5		2.5		
Recall Mode	None			None	None	None	Min	Min		Min		
Walk Time (s)				11.0	11.0	11.0						
Flash Dont Walk (s)				6.2	6.2	6.2						
Pedestrian Calls (#/hr)				0	0	0						
Act Effect Green (s)		26.3			20.8	20.8		29.0			45.5	
Actuated g/C Ratio		0.30			0.24	0.24		0.33			0.52	
v/c Ratio		1.09			0.20	0.16		0.86			0.58	
Control Delay		96.1			30.6	1.1		43.4			15.1	
Queue Delay		0.0			0.0	0.0		0.0			0.0	
Total Delay		96.1			30.6	1.1		43.4			15.1	
LOS		F			C	A		D			B	
Approach Delay		96.1			15.1			43.4			15.1	
Approach LOS		F			B			D			B	
Queue Length 50th (ft)		-349			32	0		252			152	
Queue Length 95th (ft)		#565			69	4		#413			226	
Internal Link Dist (ft)		244			276			581			1043	
Turn Bay Length (ft)						50						
Base Capacity (vph)		500			341	480		657			926	
Starvation Cap Reductn		0			0	0		0			0	
Spillback Cap Reductn		0			0	0		0			0	
Storage Cap Reductn		0			0	0		0			0	
Reduced v/c Ratio		1.09			0.20	0.16		0.75			0.53	

Intersection Summary

Area Type: Other
 Cycle Length: 91.9
 Actuated Cycle Length: 87.9
 Natural Cycle: 90
 Control Type: Actuated-Uncoordinated
 Maximum v/c Ratio: 1.09
 Intersection Signal Delay: 49.7
 Intersection LOS: D
 Intersection Capacity Utilization 89.0%
 ICU Level of Service E
 Analysis Period (min) 15
 ~ Volume exceeds capacity, queue is theoretically infinite.
 Queue shown is maximum after two cycles.
 # 95th percentile volume exceeds capacity, queue may be longer.
 Queue shown is maximum after two cycles.

Splits and Phases: 1: Weston Rd (Rt 57) & Norfield Rd



Weston Town Center
2: Weston Rd (Rt 57) & School Rd

Existing
Timing Plan: PM Peak



Lane Group	WBL	WBR	NBT	NBR	SBL	SBT
Lane Configurations						
Traffic Volume (vph)	108	18	552	90	15	343
Future Volume (vph)	108	18	552	90	15	343
Ideal Flow (vphpl)	1900	1900	1900	1900	1900	1900
Lane Util. Factor	1.00	1.00	1.00	1.00	1.00	1.00
Frt		0.850	0.981			
Flt Protected	0.950					0.998
Satd. Flow (prot)	1770	1583	1827	0	0	1859
Flt Permitted	0.950					0.995
Satd. Flow (perm)	1770	1583	1827	0	0	1853
Right Turn on Red		Yes		Yes		
Satd. Flow (RTOR)		19	13			
Link Speed (mph)	25		35			35
Link Distance (ft)	151		1123			305
Travel Time (s)	4.1		21.9			5.9
Peak Hour Factor	0.95	0.95	0.95	0.95	0.95	0.95
Adj. Flow (vph)	114	19	581	95	16	361
Shared Lane Traffic (%)						
Lane Group Flow (vph)	114	19	676	0	0	377
Number of Detectors	1	1	2		1	2
Detector Template	Left	Right	Thru		Left	Thru
Leading Detector (ft)	20	20	100		20	100
Trailing Detector (ft)	0	0	0		0	0
Detector 1 Position(ft)	0	0	0		0	0
Detector 1 Size(ft)	20	20	6		20	6
Detector 1 Type	Cl+Ex	Cl+Ex	Cl+Ex		Cl+Ex	Cl+Ex
Detector 1 Channel						
Detector 1 Extend (s)	0.0	0.0	0.0		0.0	0.0
Detector 1 Queue (s)	0.0	0.0	0.0		0.0	0.0
Detector 1 Delay (s)	0.0	0.0	0.0		0.0	0.0
Detector 2 Position(ft)			94			94
Detector 2 Size(ft)			6			6
Detector 2 Type			Cl+Ex			Cl+Ex
Detector 2 Channel						
Detector 2 Extend (s)			0.0			0.0
Turn Type	Prot	Perm	NA		D.P+P	NA
Protected Phases	4		2		1	1 2
Permitted Phases		4			2	
Detector Phase	4	4	2		1	1 2
Switch Phase						
Minimum Initial (s)	7.0	7.0	15.0		7.0	
Minimum Split (s)	20.0	20.0	21.7		10.1	
Total Split (s)	19.0	19.0	46.7		18.1	
Total Split (%)	22.7%	22.7%	55.7%		21.6%	
Maximum Green (s)	14.0	14.0	40.0		15.0	
Yellow Time (s)	3.0	3.0	4.2		3.0	
All-Red Time (s)	2.0	2.0	2.5		0.1	
Lost Time Adjust (s)	0.0	0.0	0.0			
Total Lost Time (s)	5.0	5.0	6.7			

Weston Town Center
 2: Weston Rd (Rt 57) & School Rd

Existing
 Timing Plan: PM Peak



Lane Group	WBL	WBR	NBT	NBR	SBL	SBT
Lead/Lag			Lag		Lead	
Lead-Lag Optimize?			Yes		Yes	
Vehicle Extension (s)	2.0	2.0	2.5		3.0	
Recall Mode	None	None	Min		Max	
Walk Time (s)	9.0	9.0				
Flash Dont Walk (s)	6.0	6.0				
Pedestrian Calls (#/hr)	0	0				
Act Effct Green (s)	9.8	9.8	30.0			50.0
Actuated g/C Ratio	0.14	0.14	0.44			0.74
v/c Ratio	0.45	0.08	0.83			0.28
Control Delay	36.6	14.7	26.8			3.5
Queue Delay	0.0	0.0	0.0			0.0
Total Delay	36.6	14.7	26.8			3.5
LOS	D	B	C			A
Approach Delay	33.5		26.8			3.5
Approach LOS	C		C			A
Queue Length 50th (ft)	47	0	240			37
Queue Length 95th (ft)	103	18	419			82
Internal Link Dist (ft)	71		1043			225
Turn Bay Length (ft)						
Base Capacity (vph)	393	366	1163			1551
Starvation Cap Reductn	0	0	0			0
Spillback Cap Reductn	0	0	0			0
Storage Cap Reductn	0	0	0			0
Reduced v/c Ratio	0.29	0.05	0.58			0.24

Intersection Summary

Area Type:	Other
Cycle Length:	83.8
Actuated Cycle Length:	67.7
Natural Cycle:	65
Control Type:	Actuated-Uncoordinated
Maximum v/c Ratio:	0.83
Intersection Signal Delay:	20.1
Intersection LOS:	C
Intersection Capacity Utilization:	50.2%
ICU Level of Service:	A
Analysis Period (min):	15

Splits and Phases: 2: Weston Rd (Rt 57) & School Rd



Weston Town Center
1: Weston Rd (Rt 57) & Norfield Rd

Existing (Signal Changes)
Timing Plan: PM Peak



Lane Group	EBL	EBT	EBR	WBL	WBT	WBR	NBL	NBT	NBR	SBL	SBT	SBR
Lane Configurations		↕			↕	↕		↕			↕	
Traffic Volume (vph)	143	220	164	25	41	73	32	420	28	77	344	57
Future Volume (vph)	143	220	164	25	41	73	32	420	28	77	344	57
Ideal Flow (vphp)	1900	1900	1900	1900	1900	1900	1900	1900	1900	1900	1900	1900
Storage Length (ft)	0		0	0		50	0		0	0		0
Storage Lanes	0		0	0		1	0		0	0		0
Taper Length (ft)	25			25			25			25		
Lane Util. Factor	1.00	1.00	1.00	1.00	1.00	1.00	1.00	1.00	1.00	1.00	1.00	1.00
Frt		0.958				0.850		0.992			0.984	
Flt Protected		0.987			0.981			0.997			0.992	
Satd. Flow (prot)	0	1761	0	0	1827	1583	0	1842	0	0	1818	0
Flt Permitted		0.889			0.735			0.941			0.831	
Satd. Flow (perm)	0	1586	0	0	1369	1583	0	1739	0	0	1523	0
Right Turn on Red			Yes			Yes			Yes			No
Satd. Flow (RTOR)		28				142		4				
Link Speed (mph)		25			25			35			35	
Link Distance (ft)		324			356			661			1123	
Travel Time (s)		8.8			9.7			12.9			21.9	
Peak Hour Factor	0.97	0.97	0.97	0.97	0.97	0.97	0.97	0.97	0.97	0.97	0.97	0.97
Adj. Flow (vph)	147	227	169	26	42	75	33	433	29	79	355	59
Shared Lane Traffic (%)												
Lane Group Flow (vph)	0	543	0	0	68	75	0	495	0	0	493	0
Number of Detectors	1	2		1	2	1	1	2		1	2	
Detector Template	Left	Thru		Left	Thru	Right	Left	Thru		Left	Thru	
Leading Detector (ft)	20	100		20	100	20	20	100		20	100	
Trailing Detector (ft)	0	0		0	0	0	0	0		0	0	
Detector 1 Position(ft)	0	0		0	0	0	0	0		0	0	
Detector 1 Size(ft)	20	6		20	6	20	20	6		20	6	
Detector 1 Type	Cl+Ex	Cl+Ex		Cl+Ex	Cl+Ex	Cl+Ex	Cl+Ex	Cl+Ex		Cl+Ex	Cl+Ex	
Detector 1 Channel												
Detector 1 Extend (s)	0.0	0.0		0.0	0.0	0.0	0.0	0.0		0.0	0.0	
Detector 1 Queue (s)	0.0	0.0		0.0	0.0	0.0	0.0	0.0		0.0	0.0	
Detector 1 Delay (s)	0.0	0.0		0.0	0.0	0.0	0.0	0.0		0.0	0.0	
Detector 2 Position(ft)		94			94			94			94	
Detector 2 Size(ft)		6			6			6			6	
Detector 2 Type		Cl+Ex			Cl+Ex			Cl+Ex			Cl+Ex	
Detector 2 Channel												
Detector 2 Extend (s)		0.0			0.0			0.0			0.0	
Turn Type	D.P+P	NA		Perm	NA	Perm	Perm	NA		D.P+P	NA	
Protected Phases	4	4 5			5			2		1	1 2	
Permitted Phases	5			5		5	2			2		
Detector Phase	4	4 5		5	5	5	2	2		1	1 2	
Switch Phase												
Minimum Initial (s)	5.0			7.0	7.0	7.0	15.0	15.0		5.0		
Minimum Split (s)	9.0			21.7	21.7	21.7	21.7	21.7		9.0		
Total Split (s)	18.0			21.7	21.7	21.7	39.3	39.3		11.0		
Total Split (%)	20.0%			24.1%	24.1%	24.1%	43.7%	43.7%		12.2%		
Maximum Green (s)	14.0			17.2	17.2	17.2	32.6	32.6		7.0		
Yellow Time (s)	3.0			3.5	3.5	3.5	4.2	4.2		3.0		

Weston Town Center
1: Weston Rd (Rt 57) & Norfield Rd

Existing (Signal Changes)
Timing Plan: PM Peak



Lane Group	EBL	EBT	EBR	WBL	WBT	WBR	NBL	NBT	NBR	SBL	SBT	SBR
All-Red Time (s)	1.0			1.0	1.0	1.0	2.5	2.5		1.0		
Lost Time Adjust (s)					0.0	0.0		0.0				
Total Lost Time (s)					4.5	4.5		6.7				
Lead/Lag							Lag	Lag		Lead		
Lead-Lag Optimize?							Yes	Yes		Yes		
Vehicle Extension (s)	3.0			3.0	3.0	3.0	2.5	2.5		2.5		
Recall Mode	None			None	None	None	Min	Min		Min		
Walk Time (s)				11.0	11.0	11.0						
Flash Dont Walk (s)				6.2	6.2	6.2						
Pedestrian Calls (#/hr)				0	0	0						
Act Effect Green (s)		30.0			15.4	15.4		28.5				38.3
Actuated g/C Ratio		0.36			0.18	0.18		0.34				0.45
v/c Ratio		0.89			0.27	0.19		0.84				0.69
Control Delay		41.9			34.1	1.3		40.1				22.7
Queue Delay		0.0			0.0	0.0		0.0				0.0
Total Delay		41.9			34.1	1.3		40.1				22.7
LOS		D			C	A		D				C
Approach Delay		41.9			16.9			40.1				22.7
Approach LOS		D			B			D				C
Queue Length 50th (ft)		247			33	0		245				177
Queue Length 95th (ft)		#476			72	3		#402				266
Internal Link Dist (ft)		244			276			581				1043
Turn Bay Length (ft)						50						
Base Capacity (vph)		647			281	438		680				794
Starvation Cap Reductn		0			0	0		0				0
Spillback Cap Reductn		0			0	0		0				0
Storage Cap Reductn		0			0	0		0				0
Reduced v/c Ratio		0.84			0.24	0.17		0.73				0.62

Intersection Summary

Area Type: Other
 Cycle Length: 90
 Actuated Cycle Length: 84.5
 Natural Cycle: 90
 Control Type: Actuated-Uncoordinated
 Maximum v/c Ratio: 0.89
 Intersection Signal Delay: 33.6
 Intersection LOS: C
 Intersection Capacity Utilization 89.0%
 ICU Level of Service E
 Analysis Period (min) 15
 # 95th percentile volume exceeds capacity, queue may be longer.
 Queue shown is maximum after two cycles.

Splits and Phases: 1: Weston Rd (Rt 57) & Norfield Rd



Development Area A

PERCENT INBOUND

Intersection 1 Weston Rd (Rt 57) @ Norfield Rd						
		SBR	SBT	SBL		
		0%	0%	0%		
EBL	20%				20%	WBR
EBT	0%				0%	WBT
EBR	0%				0%	WBL
		0%	30%	0%		
		NBL	NBT	NBR		

Intersection 2 Weston Rd (Rt 57) @ School Rd						
		SBR	SBT	SBL		
		0%	0%	30%		
EBL	0%				0%	WBR
EBT	0%				0%	WBT
EBR	0%				0%	WBL
		0%	0%	70%		
		NBL	NBT	NBR		

Intersection 3 Weston Rd (Rt 57) @ Development B,C & D Dwys						
		SBR	SBT	SBL		
		0%	0%	0%		
EBL	0%				0%	WBR
EBT	0%				0%	WBT
EBR	0%				0%	WBL
		0%	70%	0%		
		NBL	NBT	NBR		

Intersection 4 Norfield Rd @ Development C & E Dwys						
		SBR	SBT	SBL		
		0%	0%	0%		
EBL	0%				0%	WBR
EBT	20%				0%	WBT
EBR	0%				0%	WBL
		0%	0%	0%		
		NBL	NBT	NBR		

Intersection 5 Norfield Rd @ Development D & F Dwys						
		SBR	SBT	SBL		
		0%	0%	0%		
EBL	0%				0%	WBR
EBT	0%				20%	WBT
EBR	0%				0%	WBL
		0%	0%	0%		
		NBL	NBT	NBR		

PERCENT OUTBOUND

Intersection 1 Weston Rd (Rt 57) @ Norfield Rd						
		SBR	SBT	SBL		
		20%	30%	20%		
EBL	0%				0%	WBR
EBT	0%				0%	WBT
EBR	0%				0%	WBL
		0%	0%	0%		
		NBL	NBT	NBR		

Intersection 2 Weston Rd (Rt 57) @ School Rd						
		SBR	SBT	SBL		
		0%	0%	0%		
EBL	0%				30%	WBR
EBT	0%				0%	WBT
EBR	0%				70%	WBL
		0%	0%	0%		
		NBL	NBT	NBR		

Intersection 3 Weston Rd (Rt 57) @ Development B,C & D Dwys						
		SBR	SBT	SBL		
		0%	70%	0%		
EBL	0%				0%	WBR
EBT	0%				0%	WBT
EBR	0%				0%	WBL
		0%	0%	0%		
		NBL	NBT	NBR		

Intersection 4 Norfield Rd @ Development C & E Dwys						
		SBR	SBT	SBL		
		0%	0%	0%		
EBL	0%				0%	WBR
EBT	0%				20%	WBT
EBR	0%				0%	WBL
		0%	0%	0%		
		NBL	NBT	NBR		

Intersection 5 Norfield Rd @ Development D & F Dwys						
		SBR	SBT	SBL		
		0%	0%	0%		
EBL	0%				0%	WBR
EBT	20%				0%	WBT
EBR	0%				0%	WBL
		0%	0%	0%		
		NBL	NBT	NBR		

<table border="1"> <tr> <td data-bbox="151 155 232 300"> 1 0/1 2/3 0/1 J I L Weston Rd </td> <td data-bbox="232 155 475 300"> 1/1 0/0 0/0 J I L Norfield Rd </td> <td data-bbox="232 300 475 422"> 0/0 2/1 0/0 J I L Norfield Rd </td> </tr> </table>	1 0/1 2/3 0/1 J I L Weston Rd	1/1 0/0 0/0 J I L Norfield Rd	0/0 2/1 0/0 J I L Norfield Rd	<table border="1"> <tr> <td data-bbox="475 155 557 300"> 2 0/0 2/2 I L Weston Rd </td> <td data-bbox="557 155 800 300"> 1/2 2/5 I L School Rd </td> <td data-bbox="557 300 800 422"> 0/0 4/3 I L </td> </tr> </table>	2 0/0 2/2 I L Weston Rd	1/2 2/5 I L School Rd	0/0 4/3 I L	<table border="1"> <tr> <td data-bbox="800 155 881 300"> 3 0/0 2/5 0/0 J I L Development B & C Dwy </td> <td data-bbox="881 155 1125 300"> 0/0 0/0 0/0 J I L Weston Rd </td> <td data-bbox="881 300 1125 422"> 0/0 4/3 0/0 J I L Development D Dwy </td> </tr> </table>	3 0/0 2/5 0/0 J I L Development B & C Dwy	0/0 0/0 0/0 J I L Weston Rd	0/0 4/3 0/0 J I L Development D Dwy	<table border="1"> <tr> <td data-bbox="1125 155 1206 300"> 4 0/0 0/0 0/0 J I L Development C Dwy </td> <td data-bbox="1206 155 1432 300"> 0/0 1/1 0/0 J I L Development E Dwy </td> <td data-bbox="1206 300 1432 422"> 0/0 0/0 0/0 J I L Norfield Rd </td> </tr> </table>	4 0/0 0/0 0/0 J I L Development C Dwy	0/0 1/1 0/0 J I L Development E Dwy	0/0 0/0 0/0 J I L Norfield Rd
1 0/1 2/3 0/1 J I L Weston Rd	1/1 0/0 0/0 J I L Norfield Rd	0/0 2/1 0/0 J I L Norfield Rd													
2 0/0 2/2 I L Weston Rd	1/2 2/5 I L School Rd	0/0 4/3 I L													
3 0/0 2/5 0/0 J I L Development B & C Dwy	0/0 0/0 0/0 J I L Weston Rd	0/0 4/3 0/0 J I L Development D Dwy													
4 0/0 0/0 0/0 J I L Development C Dwy	0/0 1/1 0/0 J I L Development E Dwy	0/0 0/0 0/0 J I L Norfield Rd													
<table border="1"> <tr> <td data-bbox="151 422 232 567"> 5 0/0 0/0 0/0 J I L Development D Dwy </td> <td data-bbox="232 422 475 567"> 0/0 1/1 0/0 J I L Norfield Rd </td> <td data-bbox="232 567 475 688"> 0/0 0/0 0/0 J I L Development F Dwy </td> </tr> </table>	5 0/0 0/0 0/0 J I L Development D Dwy	0/0 1/1 0/0 J I L Norfield Rd	0/0 0/0 0/0 J I L Development F Dwy												
5 0/0 0/0 0/0 J I L Development D Dwy	0/0 1/1 0/0 J I L Norfield Rd	0/0 0/0 0/0 J I L Development F Dwy													

LEGEND

⊕ X/Y = AM/PM Peak Hour
Turning Movements

Development Area B

PERCENT INBOUND

Intersection 1 Weston Rd (Rt 57) @ Norfield Rd						
		SBR	SBT	SBL		
		0%	0%	0%		
EBL	20%				20%	WBR
EBT	0%				0%	WBT
EBR	0%				0%	WBL
		0%	30%	0%		
		NBL	NBT	NBR		

Intersection 2 Weston Rd (Rt 57) @ School Rd						
		SBR	SBT	SBL		
		0%	30%	0%		
EBL	0%				0%	WBR
EBT	0%				0%	WBT
EBR	0%				0%	WBL
		0%	0%	0%		
		NBL	NBT	NBR		

Intersection 3 Weston Rd (Rt 57) @ Development B,C & D Dwys						
		SBR	SBT	SBL		
		30%	0%	0%		
EBL	0%				0%	WBR
EBT	0%				0%	WBT
EBR	0%				0%	WBL
		70%	0%	0%		
		NBL	NBT	NBR		

Intersection 4 Norfield Rd @ Development C & E Dwys						
		SBR	SBT	SBL		
		0%	0%	0%		
EBL	0%				0%	WBR
EBT	20%				0%	WBT
EBR	0%				0%	WBL
		0%	0%	0%		
		NBL	NBT	NBR		

Intersection 5 Norfield Rd @ Development D & F Dwys						
		SBR	SBT	SBL		
		0%	0%	0%		
EBL	0%				0%	WBR
EBT	0%				20%	WBT
EBR	0%				0%	WBL
		0%	0%	0%		
		NBL	NBT	NBR		

PERCENT OUTBOUND

Intersection 1 Weston Rd (Rt 57) @ Norfield Rd						
		SBR	SBT	SBL		
		20%	30%	20%		
EBL	0%				0%	WBR
EBT	0%				0%	WBT
EBR	0%				0%	WBL
		0%	0%	0%		
		NBL	NBT	NBR		

Intersection 2 Weston Rd (Rt 57) @ School Rd						
		SBR	SBT	SBL		
		0%	0%	0%		
EBL	0%				0%	WBR
EBT	0%				0%	WBT
EBR	0%				0%	WBL
		0%	30%	0%		
		NBL	NBT	NBR		

Intersection 3 Weston Rd (Rt 57) @ Development B,C & D Dwys						
		SBR	SBT	SBL		
		0%	0%	0%		
EBL	30%				0%	WBR
EBT	0%				0%	WBT
EBR	70%				0%	WBL
		0%	0%	0%		
		NBL	NBT	NBR		

Intersection 4 Norfield Rd @ Development C & E Dwys						
		SBR	SBT	SBL		
		0%	0%	0%		
EBL	0%				0%	WBR
EBT	0%				20%	WBT
EBR	0%				0%	WBL
		0%	0%	0%		
		NBL	NBT	NBR		

Intersection 5 Norfield Rd @ Development D & F Dwys						
		SBR	SBT	SBL		
		0%	0%	0%		
EBL	0%				0%	WBR
EBT	20%				0%	WBT
EBR	0%				0%	WBL
		0%	0%	0%		
		NBL	NBT	NBR		

<table border="1"> <tr> <td> <div style="border: 1px solid black; padding: 2px;">1</div> </td> <td> <table border="1"> <tr> <td> <table border="1"> <tr> <td>4/6 J</td> <td>7/10 I</td> <td>4/6 L</td> <td>Weston Rd</td> </tr> <tr> <td>7/5 J</td> <td>0/0 I</td> <td>0/0 L</td> <td>Norfield Rd</td> </tr> </table> </td> <td> <table border="1"> <tr> <td>7/5 J</td> <td>0/0 I</td> <td>0/0 L</td> <td>Norfield Rd</td> </tr> <tr> <td>0/0 J</td> <td>0/0 I</td> <td>0/0 L</td> <td>Norfield Rd</td> </tr> </table> </td> </tr> </table> </td> <td data-bbox="472 155 794 422"> <table border="1"> <tr> <td> <div style="border: 1px solid black; padding: 2px;">2</div> </td> <td> <table border="1"> <tr> <td>10/8 I</td> <td>0/0 L</td> <td>Weston Rd</td> </tr> <tr> <td>7/9 I</td> <td>0/0 L</td> <td>School Rd</td> </tr> </table> </td> </tr> </table> </td> <td data-bbox="794 155 1115 422"> <table border="1"> <tr> <td> <div style="border: 1px solid black; padding: 2px;">3</div> </td> <td> <table border="1"> <tr> <td>10/8 J</td> <td>0/0 I</td> <td>0/0 L</td> <td>Weston Rd</td> </tr> <tr> <td>7/9 J</td> <td>0/0 I</td> <td>15/22 L</td> <td>Development B & C Dwy</td> </tr> </table> </td> <td> <table border="1"> <tr> <td>25/19 J</td> <td>0/0 I</td> <td>0/0 L</td> <td>Weston Rd</td> </tr> <tr> <td>0/0 J</td> <td>0/0 I</td> <td>0/0 L</td> <td>Development D Dwy</td> </tr> </table> </td> </tr> </table> </td> <td data-bbox="1115 155 1432 422"> <table border="1"> <tr> <td> <div style="border: 1px solid black; padding: 2px;">4</div> </td> <td> <table border="1"> <tr> <td>0/0 J</td> <td>0/0 I</td> <td>0/0 L</td> <td>Development C Dwy</td> </tr> <tr> <td>0/0 J</td> <td>7/5 I</td> <td>0/0 L</td> <td>Development E Dwy</td> </tr> </table> </td> <td> <table border="1"> <tr> <td>0/0 J</td> <td>0/0 I</td> <td>0/0 L</td> <td>Norfield Rd</td> </tr> <tr> <td>0/0 J</td> <td>0/0 I</td> <td>0/0 L</td> <td>Norfield Rd</td> </tr> </table> </td> </tr> </table> </td> </tr> <tr> <td data-bbox="151 422 472 688"> <table border="1"> <tr> <td> <div style="border: 1px solid black; padding: 2px;">5</div> </td> <td> <table border="1"> <tr> <td>0/0 J</td> <td>0/0 I</td> <td>0/0 L</td> <td>Development D Dwy</td> </tr> <tr> <td>0/0 J</td> <td>4/6 I</td> <td>0/0 L</td> <td>Development F Dwy</td> </tr> </table> </td> <td> <table border="1"> <tr> <td>0/0 J</td> <td>0/0 I</td> <td>0/0 L</td> <td>Norfield Rd</td> </tr> <tr> <td>0/0 J</td> <td>0/0 I</td> <td>0/0 L</td> <td>Norfield Rd</td> </tr> </table> </td> </tr> </table> </td> <td></td> <td></td> <td></td> </tr> </table>	<div style="border: 1px solid black; padding: 2px;">1</div>	<table border="1"> <tr> <td> <table border="1"> <tr> <td>4/6 J</td> <td>7/10 I</td> <td>4/6 L</td> <td>Weston Rd</td> </tr> <tr> <td>7/5 J</td> <td>0/0 I</td> <td>0/0 L</td> <td>Norfield Rd</td> </tr> </table> </td> <td> <table border="1"> <tr> <td>7/5 J</td> <td>0/0 I</td> <td>0/0 L</td> <td>Norfield Rd</td> </tr> <tr> <td>0/0 J</td> <td>0/0 I</td> <td>0/0 L</td> <td>Norfield Rd</td> </tr> </table> </td> </tr> </table>	<table border="1"> <tr> <td>4/6 J</td> <td>7/10 I</td> <td>4/6 L</td> <td>Weston Rd</td> </tr> <tr> <td>7/5 J</td> <td>0/0 I</td> <td>0/0 L</td> <td>Norfield Rd</td> </tr> </table>	4/6 J	7/10 I	4/6 L	Weston Rd	7/5 J	0/0 I	0/0 L	Norfield Rd	<table border="1"> <tr> <td>7/5 J</td> <td>0/0 I</td> <td>0/0 L</td> <td>Norfield Rd</td> </tr> <tr> <td>0/0 J</td> <td>0/0 I</td> <td>0/0 L</td> <td>Norfield Rd</td> </tr> </table>	7/5 J	0/0 I	0/0 L	Norfield Rd	0/0 J	0/0 I	0/0 L	Norfield Rd	<table border="1"> <tr> <td> <div style="border: 1px solid black; padding: 2px;">2</div> </td> <td> <table border="1"> <tr> <td>10/8 I</td> <td>0/0 L</td> <td>Weston Rd</td> </tr> <tr> <td>7/9 I</td> <td>0/0 L</td> <td>School Rd</td> </tr> </table> </td> </tr> </table>	<div style="border: 1px solid black; padding: 2px;">2</div>	<table border="1"> <tr> <td>10/8 I</td> <td>0/0 L</td> <td>Weston Rd</td> </tr> <tr> <td>7/9 I</td> <td>0/0 L</td> <td>School Rd</td> </tr> </table>	10/8 I	0/0 L	Weston Rd	7/9 I	0/0 L	School Rd	<table border="1"> <tr> <td> <div style="border: 1px solid black; padding: 2px;">3</div> </td> <td> <table border="1"> <tr> <td>10/8 J</td> <td>0/0 I</td> <td>0/0 L</td> <td>Weston Rd</td> </tr> <tr> <td>7/9 J</td> <td>0/0 I</td> <td>15/22 L</td> <td>Development B & C Dwy</td> </tr> </table> </td> <td> <table border="1"> <tr> <td>25/19 J</td> <td>0/0 I</td> <td>0/0 L</td> <td>Weston Rd</td> </tr> <tr> <td>0/0 J</td> <td>0/0 I</td> <td>0/0 L</td> <td>Development D Dwy</td> </tr> </table> </td> </tr> </table>	<div style="border: 1px solid black; padding: 2px;">3</div>	<table border="1"> <tr> <td>10/8 J</td> <td>0/0 I</td> <td>0/0 L</td> <td>Weston Rd</td> </tr> <tr> <td>7/9 J</td> <td>0/0 I</td> <td>15/22 L</td> <td>Development B & C Dwy</td> </tr> </table>	10/8 J	0/0 I	0/0 L	Weston Rd	7/9 J	0/0 I	15/22 L	Development B & C Dwy	<table border="1"> <tr> <td>25/19 J</td> <td>0/0 I</td> <td>0/0 L</td> <td>Weston Rd</td> </tr> <tr> <td>0/0 J</td> <td>0/0 I</td> <td>0/0 L</td> <td>Development D Dwy</td> </tr> </table>	25/19 J	0/0 I	0/0 L	Weston Rd	0/0 J	0/0 I	0/0 L	Development D Dwy	<table border="1"> <tr> <td> <div style="border: 1px solid black; padding: 2px;">4</div> </td> <td> <table border="1"> <tr> <td>0/0 J</td> <td>0/0 I</td> <td>0/0 L</td> <td>Development C Dwy</td> </tr> <tr> <td>0/0 J</td> <td>7/5 I</td> <td>0/0 L</td> <td>Development E Dwy</td> </tr> </table> </td> <td> <table border="1"> <tr> <td>0/0 J</td> <td>0/0 I</td> <td>0/0 L</td> <td>Norfield Rd</td> </tr> <tr> <td>0/0 J</td> <td>0/0 I</td> <td>0/0 L</td> <td>Norfield Rd</td> </tr> </table> </td> </tr> </table>	<div style="border: 1px solid black; padding: 2px;">4</div>	<table border="1"> <tr> <td>0/0 J</td> <td>0/0 I</td> <td>0/0 L</td> <td>Development C Dwy</td> </tr> <tr> <td>0/0 J</td> <td>7/5 I</td> <td>0/0 L</td> <td>Development E Dwy</td> </tr> </table>	0/0 J	0/0 I	0/0 L	Development C Dwy	0/0 J	7/5 I	0/0 L	Development E Dwy	<table border="1"> <tr> <td>0/0 J</td> <td>0/0 I</td> <td>0/0 L</td> <td>Norfield Rd</td> </tr> <tr> <td>0/0 J</td> <td>0/0 I</td> <td>0/0 L</td> <td>Norfield Rd</td> </tr> </table>	0/0 J	0/0 I	0/0 L	Norfield Rd	0/0 J	0/0 I	0/0 L	Norfield Rd	<table border="1"> <tr> <td> <div style="border: 1px solid black; padding: 2px;">5</div> </td> <td> <table border="1"> <tr> <td>0/0 J</td> <td>0/0 I</td> <td>0/0 L</td> <td>Development D Dwy</td> </tr> <tr> <td>0/0 J</td> <td>4/6 I</td> <td>0/0 L</td> <td>Development F Dwy</td> </tr> </table> </td> <td> <table border="1"> <tr> <td>0/0 J</td> <td>0/0 I</td> <td>0/0 L</td> <td>Norfield Rd</td> </tr> <tr> <td>0/0 J</td> <td>0/0 I</td> <td>0/0 L</td> <td>Norfield Rd</td> </tr> </table> </td> </tr> </table>	<div style="border: 1px solid black; padding: 2px;">5</div>	<table border="1"> <tr> <td>0/0 J</td> <td>0/0 I</td> <td>0/0 L</td> <td>Development D Dwy</td> </tr> <tr> <td>0/0 J</td> <td>4/6 I</td> <td>0/0 L</td> <td>Development F Dwy</td> </tr> </table>	0/0 J	0/0 I	0/0 L	Development D Dwy	0/0 J	4/6 I	0/0 L	Development F Dwy	<table border="1"> <tr> <td>0/0 J</td> <td>0/0 I</td> <td>0/0 L</td> <td>Norfield Rd</td> </tr> <tr> <td>0/0 J</td> <td>0/0 I</td> <td>0/0 L</td> <td>Norfield Rd</td> </tr> </table>	0/0 J	0/0 I	0/0 L	Norfield Rd	0/0 J	0/0 I	0/0 L	Norfield Rd			
<div style="border: 1px solid black; padding: 2px;">1</div>	<table border="1"> <tr> <td> <table border="1"> <tr> <td>4/6 J</td> <td>7/10 I</td> <td>4/6 L</td> <td>Weston Rd</td> </tr> <tr> <td>7/5 J</td> <td>0/0 I</td> <td>0/0 L</td> <td>Norfield Rd</td> </tr> </table> </td> <td> <table border="1"> <tr> <td>7/5 J</td> <td>0/0 I</td> <td>0/0 L</td> <td>Norfield Rd</td> </tr> <tr> <td>0/0 J</td> <td>0/0 I</td> <td>0/0 L</td> <td>Norfield Rd</td> </tr> </table> </td> </tr> </table>	<table border="1"> <tr> <td>4/6 J</td> <td>7/10 I</td> <td>4/6 L</td> <td>Weston Rd</td> </tr> <tr> <td>7/5 J</td> <td>0/0 I</td> <td>0/0 L</td> <td>Norfield Rd</td> </tr> </table>	4/6 J	7/10 I	4/6 L	Weston Rd	7/5 J	0/0 I	0/0 L	Norfield Rd	<table border="1"> <tr> <td>7/5 J</td> <td>0/0 I</td> <td>0/0 L</td> <td>Norfield Rd</td> </tr> <tr> <td>0/0 J</td> <td>0/0 I</td> <td>0/0 L</td> <td>Norfield Rd</td> </tr> </table>	7/5 J	0/0 I	0/0 L	Norfield Rd	0/0 J	0/0 I	0/0 L	Norfield Rd	<table border="1"> <tr> <td> <div style="border: 1px solid black; padding: 2px;">2</div> </td> <td> <table border="1"> <tr> <td>10/8 I</td> <td>0/0 L</td> <td>Weston Rd</td> </tr> <tr> <td>7/9 I</td> <td>0/0 L</td> <td>School Rd</td> </tr> </table> </td> </tr> </table>	<div style="border: 1px solid black; padding: 2px;">2</div>	<table border="1"> <tr> <td>10/8 I</td> <td>0/0 L</td> <td>Weston Rd</td> </tr> <tr> <td>7/9 I</td> <td>0/0 L</td> <td>School Rd</td> </tr> </table>	10/8 I	0/0 L	Weston Rd	7/9 I	0/0 L	School Rd	<table border="1"> <tr> <td> <div style="border: 1px solid black; padding: 2px;">3</div> </td> <td> <table border="1"> <tr> <td>10/8 J</td> <td>0/0 I</td> <td>0/0 L</td> <td>Weston Rd</td> </tr> <tr> <td>7/9 J</td> <td>0/0 I</td> <td>15/22 L</td> <td>Development B & C Dwy</td> </tr> </table> </td> <td> <table border="1"> <tr> <td>25/19 J</td> <td>0/0 I</td> <td>0/0 L</td> <td>Weston Rd</td> </tr> <tr> <td>0/0 J</td> <td>0/0 I</td> <td>0/0 L</td> <td>Development D Dwy</td> </tr> </table> </td> </tr> </table>	<div style="border: 1px solid black; padding: 2px;">3</div>	<table border="1"> <tr> <td>10/8 J</td> <td>0/0 I</td> <td>0/0 L</td> <td>Weston Rd</td> </tr> <tr> <td>7/9 J</td> <td>0/0 I</td> <td>15/22 L</td> <td>Development B & C Dwy</td> </tr> </table>	10/8 J	0/0 I	0/0 L	Weston Rd	7/9 J	0/0 I	15/22 L	Development B & C Dwy	<table border="1"> <tr> <td>25/19 J</td> <td>0/0 I</td> <td>0/0 L</td> <td>Weston Rd</td> </tr> <tr> <td>0/0 J</td> <td>0/0 I</td> <td>0/0 L</td> <td>Development D Dwy</td> </tr> </table>	25/19 J	0/0 I	0/0 L	Weston Rd	0/0 J	0/0 I	0/0 L	Development D Dwy	<table border="1"> <tr> <td> <div style="border: 1px solid black; padding: 2px;">4</div> </td> <td> <table border="1"> <tr> <td>0/0 J</td> <td>0/0 I</td> <td>0/0 L</td> <td>Development C Dwy</td> </tr> <tr> <td>0/0 J</td> <td>7/5 I</td> <td>0/0 L</td> <td>Development E Dwy</td> </tr> </table> </td> <td> <table border="1"> <tr> <td>0/0 J</td> <td>0/0 I</td> <td>0/0 L</td> <td>Norfield Rd</td> </tr> <tr> <td>0/0 J</td> <td>0/0 I</td> <td>0/0 L</td> <td>Norfield Rd</td> </tr> </table> </td> </tr> </table>	<div style="border: 1px solid black; padding: 2px;">4</div>	<table border="1"> <tr> <td>0/0 J</td> <td>0/0 I</td> <td>0/0 L</td> <td>Development C Dwy</td> </tr> <tr> <td>0/0 J</td> <td>7/5 I</td> <td>0/0 L</td> <td>Development E Dwy</td> </tr> </table>	0/0 J	0/0 I	0/0 L	Development C Dwy	0/0 J	7/5 I	0/0 L	Development E Dwy	<table border="1"> <tr> <td>0/0 J</td> <td>0/0 I</td> <td>0/0 L</td> <td>Norfield Rd</td> </tr> <tr> <td>0/0 J</td> <td>0/0 I</td> <td>0/0 L</td> <td>Norfield Rd</td> </tr> </table>	0/0 J	0/0 I	0/0 L	Norfield Rd	0/0 J	0/0 I	0/0 L	Norfield Rd																								
<table border="1"> <tr> <td>4/6 J</td> <td>7/10 I</td> <td>4/6 L</td> <td>Weston Rd</td> </tr> <tr> <td>7/5 J</td> <td>0/0 I</td> <td>0/0 L</td> <td>Norfield Rd</td> </tr> </table>	4/6 J	7/10 I	4/6 L	Weston Rd	7/5 J	0/0 I	0/0 L	Norfield Rd	<table border="1"> <tr> <td>7/5 J</td> <td>0/0 I</td> <td>0/0 L</td> <td>Norfield Rd</td> </tr> <tr> <td>0/0 J</td> <td>0/0 I</td> <td>0/0 L</td> <td>Norfield Rd</td> </tr> </table>	7/5 J	0/0 I	0/0 L	Norfield Rd	0/0 J	0/0 I	0/0 L	Norfield Rd																																																																											
4/6 J	7/10 I	4/6 L	Weston Rd																																																																																									
7/5 J	0/0 I	0/0 L	Norfield Rd																																																																																									
7/5 J	0/0 I	0/0 L	Norfield Rd																																																																																									
0/0 J	0/0 I	0/0 L	Norfield Rd																																																																																									
<div style="border: 1px solid black; padding: 2px;">2</div>	<table border="1"> <tr> <td>10/8 I</td> <td>0/0 L</td> <td>Weston Rd</td> </tr> <tr> <td>7/9 I</td> <td>0/0 L</td> <td>School Rd</td> </tr> </table>	10/8 I	0/0 L	Weston Rd	7/9 I	0/0 L	School Rd																																																																																					
10/8 I	0/0 L	Weston Rd																																																																																										
7/9 I	0/0 L	School Rd																																																																																										
<div style="border: 1px solid black; padding: 2px;">3</div>	<table border="1"> <tr> <td>10/8 J</td> <td>0/0 I</td> <td>0/0 L</td> <td>Weston Rd</td> </tr> <tr> <td>7/9 J</td> <td>0/0 I</td> <td>15/22 L</td> <td>Development B & C Dwy</td> </tr> </table>	10/8 J	0/0 I	0/0 L	Weston Rd	7/9 J	0/0 I	15/22 L	Development B & C Dwy	<table border="1"> <tr> <td>25/19 J</td> <td>0/0 I</td> <td>0/0 L</td> <td>Weston Rd</td> </tr> <tr> <td>0/0 J</td> <td>0/0 I</td> <td>0/0 L</td> <td>Development D Dwy</td> </tr> </table>	25/19 J	0/0 I	0/0 L	Weston Rd	0/0 J	0/0 I	0/0 L	Development D Dwy																																																																										
10/8 J	0/0 I	0/0 L	Weston Rd																																																																																									
7/9 J	0/0 I	15/22 L	Development B & C Dwy																																																																																									
25/19 J	0/0 I	0/0 L	Weston Rd																																																																																									
0/0 J	0/0 I	0/0 L	Development D Dwy																																																																																									
<div style="border: 1px solid black; padding: 2px;">4</div>	<table border="1"> <tr> <td>0/0 J</td> <td>0/0 I</td> <td>0/0 L</td> <td>Development C Dwy</td> </tr> <tr> <td>0/0 J</td> <td>7/5 I</td> <td>0/0 L</td> <td>Development E Dwy</td> </tr> </table>	0/0 J	0/0 I	0/0 L	Development C Dwy	0/0 J	7/5 I	0/0 L	Development E Dwy	<table border="1"> <tr> <td>0/0 J</td> <td>0/0 I</td> <td>0/0 L</td> <td>Norfield Rd</td> </tr> <tr> <td>0/0 J</td> <td>0/0 I</td> <td>0/0 L</td> <td>Norfield Rd</td> </tr> </table>	0/0 J	0/0 I	0/0 L	Norfield Rd	0/0 J	0/0 I	0/0 L	Norfield Rd																																																																										
0/0 J	0/0 I	0/0 L	Development C Dwy																																																																																									
0/0 J	7/5 I	0/0 L	Development E Dwy																																																																																									
0/0 J	0/0 I	0/0 L	Norfield Rd																																																																																									
0/0 J	0/0 I	0/0 L	Norfield Rd																																																																																									
<table border="1"> <tr> <td> <div style="border: 1px solid black; padding: 2px;">5</div> </td> <td> <table border="1"> <tr> <td>0/0 J</td> <td>0/0 I</td> <td>0/0 L</td> <td>Development D Dwy</td> </tr> <tr> <td>0/0 J</td> <td>4/6 I</td> <td>0/0 L</td> <td>Development F Dwy</td> </tr> </table> </td> <td> <table border="1"> <tr> <td>0/0 J</td> <td>0/0 I</td> <td>0/0 L</td> <td>Norfield Rd</td> </tr> <tr> <td>0/0 J</td> <td>0/0 I</td> <td>0/0 L</td> <td>Norfield Rd</td> </tr> </table> </td> </tr> </table>	<div style="border: 1px solid black; padding: 2px;">5</div>	<table border="1"> <tr> <td>0/0 J</td> <td>0/0 I</td> <td>0/0 L</td> <td>Development D Dwy</td> </tr> <tr> <td>0/0 J</td> <td>4/6 I</td> <td>0/0 L</td> <td>Development F Dwy</td> </tr> </table>	0/0 J	0/0 I	0/0 L	Development D Dwy	0/0 J	4/6 I	0/0 L	Development F Dwy	<table border="1"> <tr> <td>0/0 J</td> <td>0/0 I</td> <td>0/0 L</td> <td>Norfield Rd</td> </tr> <tr> <td>0/0 J</td> <td>0/0 I</td> <td>0/0 L</td> <td>Norfield Rd</td> </tr> </table>	0/0 J	0/0 I	0/0 L	Norfield Rd	0/0 J	0/0 I	0/0 L	Norfield Rd																																																																									
<div style="border: 1px solid black; padding: 2px;">5</div>	<table border="1"> <tr> <td>0/0 J</td> <td>0/0 I</td> <td>0/0 L</td> <td>Development D Dwy</td> </tr> <tr> <td>0/0 J</td> <td>4/6 I</td> <td>0/0 L</td> <td>Development F Dwy</td> </tr> </table>	0/0 J	0/0 I	0/0 L	Development D Dwy	0/0 J	4/6 I	0/0 L	Development F Dwy	<table border="1"> <tr> <td>0/0 J</td> <td>0/0 I</td> <td>0/0 L</td> <td>Norfield Rd</td> </tr> <tr> <td>0/0 J</td> <td>0/0 I</td> <td>0/0 L</td> <td>Norfield Rd</td> </tr> </table>	0/0 J	0/0 I	0/0 L	Norfield Rd	0/0 J	0/0 I	0/0 L	Norfield Rd																																																																										
0/0 J	0/0 I	0/0 L	Development D Dwy																																																																																									
0/0 J	4/6 I	0/0 L	Development F Dwy																																																																																									
0/0 J	0/0 I	0/0 L	Norfield Rd																																																																																									
0/0 J	0/0 I	0/0 L	Norfield Rd																																																																																									

LEGEND

⊕ X/Y = AM/PM Peak Hour
Turning Movements

Development Area C

PERCENT INBOUND

Intersection 1 Weston Rd (Rt 57) @ Norfield Rd						
		SBR	SBT	SBL		
		0%	0%	0%		
EBL	0%				0%	WBR
EBT	0%				20%	WBT
EBR	0%				0%	WBL
		30%	0%	0%		
		NBL	NBT	NBR		

Intersection 2 Weston Rd (Rt 57) @ School Rd						
		SBR	SBT	SBL		
		0%	30%	0%		
EBL	0%				0%	WBR
EBT	0%				0%	WBT
EBR	0%				0%	WBL
		0%	0%	0%		
		NBL	NBT	NBR		

Intersection 3 Weston Rd (Rt 57) @ Development B,C & D Dwys						
		SBR	SBT	SBL		
		30%	0%	0%		
EBL	0%				0%	WBR
EBT	0%				0%	WBT
EBR	0%				0%	WBL
		0%	0%	0%		
		NBL	NBT	NBR		

Intersection 4 Norfield Rd @ Development C & E Dwys						
		SBR	SBT	SBL		
		0%	0%	0%		
EBL	20%				50%	WBR
EBT	0%				0%	WBT
EBR	0%				0%	WBL
		0%	0%	0%		
		NBL	NBT	NBR		

Intersection 5 Norfield Rd @ Development D & F Dwys						
		SBR	SBT	SBL		
		0%	0%	0%		
EBL	0%				0%	WBR
EBT	0%				20%	WBT
EBR	0%				0%	WBL
		0%	0%	0%		
		NBL	NBT	NBR		

PERCENT OUTBOUND

Intersection 1 Weston Rd (Rt 57) @ Norfield Rd						
		SBR	SBT	SBL		
		0%	0%	0%		
EBL	0%				0%	WBR
EBT	20%				0%	WBT
EBR	30%				0%	WBL
		0%	0%	0%		
		NBL	NBT	NBR		

Intersection 2 Weston Rd (Rt 57) @ School Rd						
		SBR	SBT	SBL		
		0%	0%	0%		
EBL	0%				0%	WBR
EBT	0%				0%	WBT
EBR	0%				0%	WBL
		0%	30%	0%		
		NBL	NBT	NBR		

Intersection 3 Weston Rd (Rt 57) @ Development B,C & D Dwys						
		SBR	SBT	SBL		
		0%	0%	0%		
EBL	30%				0%	WBR
EBT	0%				0%	WBT
EBR	0%				0%	WBL
		0%	0%	0%		
		NBL	NBT	NBR		

Intersection 4 Norfield Rd @ Development C & E Dwys						
		SBR	SBT	SBL		
		20%	0%	50%		
EBL	0%				0%	WBR
EBT	0%				0%	WBT
EBR	0%				0%	WBL
		0%	0%	0%		
		NBL	NBT	NBR		

Intersection 5 Norfield Rd @ Development D & F Dwys						
		SBR	SBT	SBL		
		0%	0%	0%		
EBL	0%				0%	WBR
EBT	20%				0%	WBT
EBR	0%				0%	WBL
		0%	0%	0%		
		NBL	NBT	NBR		

<table border="1"> <tr> <td> <table border="1"> <tr> <td>0/0 0/0 0/0</td> <td>Weston Rd</td> </tr> <tr> <td>J I L</td> <td>0/0 1/4 0/0</td> </tr> </table> </td> <td> <table border="1"> <tr> <td>0/0 1/3 1/4</td> <td>Norfield Rd</td> </tr> <tr> <td>J I L</td> <td>1/7 0/0 0/0</td> </tr> </table> </td> </tr> </table>	<table border="1"> <tr> <td>0/0 0/0 0/0</td> <td>Weston Rd</td> </tr> <tr> <td>J I L</td> <td>0/0 1/4 0/0</td> </tr> </table>	0/0 0/0 0/0	Weston Rd	J I L	0/0 1/4 0/0	<table border="1"> <tr> <td>0/0 1/3 1/4</td> <td>Norfield Rd</td> </tr> <tr> <td>J I L</td> <td>1/7 0/0 0/0</td> </tr> </table>	0/0 1/3 1/4	Norfield Rd	J I L	1/7 0/0 0/0	<table border="1"> <tr> <td> <table border="1"> <tr> <td>1/7 0/0</td> <td>Weston Rd</td> </tr> <tr> <td>I L</td> <td>0/0 0/0</td> </tr> </table> </td> <td> <table border="1"> <tr> <td>1/5 0/0</td> <td>School Rd</td> </tr> <tr> <td>I L</td> <td></td> </tr> </table> </td> </tr> </table>	<table border="1"> <tr> <td>1/7 0/0</td> <td>Weston Rd</td> </tr> <tr> <td>I L</td> <td>0/0 0/0</td> </tr> </table>	1/7 0/0	Weston Rd	I L	0/0 0/0	<table border="1"> <tr> <td>1/5 0/0</td> <td>School Rd</td> </tr> <tr> <td>I L</td> <td></td> </tr> </table>	1/5 0/0	School Rd	I L		<table border="1"> <tr> <td> <table border="1"> <tr> <td>1/7 0/0 0/0</td> <td>Weston Rd</td> </tr> <tr> <td>J I L</td> <td>0/0 0/0 0/0</td> </tr> </table> </td> <td> <table border="1"> <tr> <td>1/5 0/0 0/0</td> <td>Development B & C Dwy</td> </tr> <tr> <td>J I L</td> <td></td> </tr> </table> </td> </tr> </table>	<table border="1"> <tr> <td>1/7 0/0 0/0</td> <td>Weston Rd</td> </tr> <tr> <td>J I L</td> <td>0/0 0/0 0/0</td> </tr> </table>	1/7 0/0 0/0	Weston Rd	J I L	0/0 0/0 0/0	<table border="1"> <tr> <td>1/5 0/0 0/0</td> <td>Development B & C Dwy</td> </tr> <tr> <td>J I L</td> <td></td> </tr> </table>	1/5 0/0 0/0	Development B & C Dwy	J I L		<table border="1"> <tr> <td> <table border="1"> <tr> <td>1/3 0/0 2/7</td> <td>Development C Dwy</td> </tr> <tr> <td>J I L</td> <td></td> </tr> </table> </td> <td> <table border="1"> <tr> <td>1/4 0/0 0/0</td> <td>Development E Dwy</td> </tr> <tr> <td>J I L</td> <td></td> </tr> </table> </td> </tr> </table>	<table border="1"> <tr> <td>1/3 0/0 2/7</td> <td>Development C Dwy</td> </tr> <tr> <td>J I L</td> <td></td> </tr> </table>	1/3 0/0 2/7	Development C Dwy	J I L		<table border="1"> <tr> <td>1/4 0/0 0/0</td> <td>Development E Dwy</td> </tr> <tr> <td>J I L</td> <td></td> </tr> </table>	1/4 0/0 0/0	Development E Dwy	J I L	
<table border="1"> <tr> <td>0/0 0/0 0/0</td> <td>Weston Rd</td> </tr> <tr> <td>J I L</td> <td>0/0 1/4 0/0</td> </tr> </table>	0/0 0/0 0/0	Weston Rd	J I L	0/0 1/4 0/0	<table border="1"> <tr> <td>0/0 1/3 1/4</td> <td>Norfield Rd</td> </tr> <tr> <td>J I L</td> <td>1/7 0/0 0/0</td> </tr> </table>	0/0 1/3 1/4	Norfield Rd	J I L	1/7 0/0 0/0																																		
0/0 0/0 0/0	Weston Rd																																										
J I L	0/0 1/4 0/0																																										
0/0 1/3 1/4	Norfield Rd																																										
J I L	1/7 0/0 0/0																																										
<table border="1"> <tr> <td>1/7 0/0</td> <td>Weston Rd</td> </tr> <tr> <td>I L</td> <td>0/0 0/0</td> </tr> </table>	1/7 0/0	Weston Rd	I L	0/0 0/0	<table border="1"> <tr> <td>1/5 0/0</td> <td>School Rd</td> </tr> <tr> <td>I L</td> <td></td> </tr> </table>	1/5 0/0	School Rd	I L																																			
1/7 0/0	Weston Rd																																										
I L	0/0 0/0																																										
1/5 0/0	School Rd																																										
I L																																											
<table border="1"> <tr> <td>1/7 0/0 0/0</td> <td>Weston Rd</td> </tr> <tr> <td>J I L</td> <td>0/0 0/0 0/0</td> </tr> </table>	1/7 0/0 0/0	Weston Rd	J I L	0/0 0/0 0/0	<table border="1"> <tr> <td>1/5 0/0 0/0</td> <td>Development B & C Dwy</td> </tr> <tr> <td>J I L</td> <td></td> </tr> </table>	1/5 0/0 0/0	Development B & C Dwy	J I L																																			
1/7 0/0 0/0	Weston Rd																																										
J I L	0/0 0/0 0/0																																										
1/5 0/0 0/0	Development B & C Dwy																																										
J I L																																											
<table border="1"> <tr> <td>1/3 0/0 2/7</td> <td>Development C Dwy</td> </tr> <tr> <td>J I L</td> <td></td> </tr> </table>	1/3 0/0 2/7	Development C Dwy	J I L		<table border="1"> <tr> <td>1/4 0/0 0/0</td> <td>Development E Dwy</td> </tr> <tr> <td>J I L</td> <td></td> </tr> </table>	1/4 0/0 0/0	Development E Dwy	J I L																																			
1/3 0/0 2/7	Development C Dwy																																										
J I L																																											
1/4 0/0 0/0	Development E Dwy																																										
J I L																																											
<table border="1"> <tr> <td> <table border="1"> <tr> <td>0/0 0/0 0/0</td> <td>Development D Dwy</td> </tr> <tr> <td>J I L</td> <td>0/0 1/4 0/0</td> </tr> </table> </td> <td> <table border="1"> <tr> <td>0/0 1/3 0/0</td> <td>Development F Dwy</td> </tr> <tr> <td>J I L</td> <td>0/0 0/0 0/0</td> </tr> </table> </td> </tr> </table>	<table border="1"> <tr> <td>0/0 0/0 0/0</td> <td>Development D Dwy</td> </tr> <tr> <td>J I L</td> <td>0/0 1/4 0/0</td> </tr> </table>	0/0 0/0 0/0	Development D Dwy	J I L	0/0 1/4 0/0	<table border="1"> <tr> <td>0/0 1/3 0/0</td> <td>Development F Dwy</td> </tr> <tr> <td>J I L</td> <td>0/0 0/0 0/0</td> </tr> </table>	0/0 1/3 0/0	Development F Dwy	J I L	0/0 0/0 0/0																																	
<table border="1"> <tr> <td>0/0 0/0 0/0</td> <td>Development D Dwy</td> </tr> <tr> <td>J I L</td> <td>0/0 1/4 0/0</td> </tr> </table>	0/0 0/0 0/0	Development D Dwy	J I L	0/0 1/4 0/0	<table border="1"> <tr> <td>0/0 1/3 0/0</td> <td>Development F Dwy</td> </tr> <tr> <td>J I L</td> <td>0/0 0/0 0/0</td> </tr> </table>	0/0 1/3 0/0	Development F Dwy	J I L	0/0 0/0 0/0																																		
0/0 0/0 0/0	Development D Dwy																																										
J I L	0/0 1/4 0/0																																										
0/0 1/3 0/0	Development F Dwy																																										
J I L	0/0 0/0 0/0																																										

LEGEND

⊕ X/Y = AM/PM Peak Hour
Turning Movements

Development Area D

PERCENT INBOUND

Intersection 1 Weston Rd (Rt 57) @ Norfield Rd						
		SBR	SBT	SBL		
		0%	0%	0%		
EBL	0%				0%	WBR
EBT	20%				0%	WBT
EBR	0%				0%	WBL
		0%	15%	15%		
		NBL	NBT	NBR		

Intersection 2 Weston Rd (Rt 57) @ School Rd						
		SBR	SBT	SBL		
		0%	30%	0%		
EBL	0%				0%	WBR
EBT	0%				0%	WBT
EBR	0%				0%	WBL
		0%	0%	0%		
		NBL	NBT	NBR		

Intersection 3 Weston Rd (Rt 57) @ Development B,C & D Dwys						
		SBR	SBT	SBL		
		0%	0%	30%		
EBL	0%				0%	WBR
EBT	0%				0%	WBT
EBR	0%				0%	WBL
		0%	0%	15%		
		NBL	NBT	NBR		

Intersection 4 Norfield Rd @ Development C & E Dwys						
		SBR	SBT	SBL		
		0%	0%	0%		
EBL	0%				0%	WBR
EBT	20%				0%	WBT
EBR	0%				0%	WBL
		0%	0%	0%		
		NBL	NBT	NBR		

Intersection 5 Norfield Rd @ Development D & F Dwys						
		SBR	SBT	SBL		
		0%	0%	0%		
EBL	35%				20%	WBR
EBT	0%				0%	WBT
EBR	0%				0%	WBL
		0%	0%	0%		
		NBL	NBT	NBR		

PERCENT OUTBOUND

Intersection 1 Weston Rd (Rt 57) @ Norfield Rd						
		SBR	SBT	SBL		
		0%	15%	0%		
EBL	0%				0%	WBR
EBT	0%				20%	WBT
EBR	0%				15%	WBL
		0%	0%	0%		
		NBL	NBT	NBR		

Intersection 2 Weston Rd (Rt 57) @ School Rd						
		SBR	SBT	SBL		
		0%	0%	0%		
EBL	0%				0%	WBR
EBT	0%				0%	WBT
EBR	0%				0%	WBL
		0%	30%	0%		
		NBL	NBT	NBR		

Intersection 3 Weston Rd (Rt 57) @ Development B,C & D Dwys						
		SBR	SBT	SBL		
		0%	0%	0%		
EBL	0%				30%	WBR
EBT	0%				0%	WBT
EBR	0%				15%	WBL
		0%	0%	0%		
		NBL	NBT	NBR		

Intersection 4 Norfield Rd @ Development C & E Dwys						
		SBR	SBT	SBL		
		0%	0%	0%		
EBL	0%				0%	WBR
EBT	0%				20%	WBT
EBR	0%				0%	WBL
		0%	0%	0%		
		NBL	NBT	NBR		

Intersection 5 Norfield Rd @ Development D & F Dwys						
		SBR	SBT	SBL		
		35%	0%	20%		
EBL	0%				0%	WBR
EBT	0%				0%	WBT
EBR	0%				0%	WBL
		0%	0%	0%		
		NBL	NBT	NBR		

<table border="1"> <tr> <td> <div style="text-align: right;">0/0 2/3 0/0</div> <div style="text-align: center;">J I L</div> <div style="text-align: right;">Weston Rd</div> </td> <td> <div style="text-align: right;">0/0 3/4 3/3</div> <div style="text-align: center;">J I L</div> <div style="text-align: right;">Norfield Rd</div> </td> </tr> <tr> <td> <div style="text-align: right;">0/0 4/5 0/0</div> <div style="text-align: center;">J I L</div> <div style="text-align: right;">Development D Dwy</div> </td> <td> <div style="text-align: right;">0/0 3/4 3/4</div> <div style="text-align: center;">J I L</div> <div style="text-align: right;">Norfield Rd</div> </td> </tr> </table>	<div style="text-align: right;">0/0 2/3 0/0</div> <div style="text-align: center;">J I L</div> <div style="text-align: right;">Weston Rd</div>	<div style="text-align: right;">0/0 3/4 3/3</div> <div style="text-align: center;">J I L</div> <div style="text-align: right;">Norfield Rd</div>	<div style="text-align: right;">0/0 4/5 0/0</div> <div style="text-align: center;">J I L</div> <div style="text-align: right;">Development D Dwy</div>	<div style="text-align: right;">0/0 3/4 3/4</div> <div style="text-align: center;">J I L</div> <div style="text-align: right;">Norfield Rd</div>	<table border="1"> <tr> <td> <div style="text-align: right;">6/7 0/0</div> <div style="text-align: center;">J I L</div> <div style="text-align: right;">Weston Rd</div> </td> <td> <div style="text-align: right;">0/0 0/0</div> <div style="text-align: center;">J I L</div> <div style="text-align: right;">School Rd</div> </td> </tr> <tr> <td> <div style="text-align: right;">5/6 0/0</div> <div style="text-align: center;">J I L</div> <div style="text-align: right;">Development B & C Dwy</div> </td> <td> <div style="text-align: right;">0/0 0/0 0/0</div> <div style="text-align: center;">J I L</div> <div style="text-align: right;">Weston Rd</div> </td> </tr> </table>	<div style="text-align: right;">6/7 0/0</div> <div style="text-align: center;">J I L</div> <div style="text-align: right;">Weston Rd</div>	<div style="text-align: right;">0/0 0/0</div> <div style="text-align: center;">J I L</div> <div style="text-align: right;">School Rd</div>	<div style="text-align: right;">5/6 0/0</div> <div style="text-align: center;">J I L</div> <div style="text-align: right;">Development B & C Dwy</div>	<div style="text-align: right;">0/0 0/0 0/0</div> <div style="text-align: center;">J I L</div> <div style="text-align: right;">Weston Rd</div>	<table border="1"> <tr> <td> <div style="text-align: right;">0/0 0/0 6/7</div> <div style="text-align: center;">J I L</div> <div style="text-align: right;">Weston Rd</div> </td> <td> <div style="text-align: right;">5/6 0/0 2/3</div> <div style="text-align: center;">J I L</div> <div style="text-align: right;">Development D Dwy</div> </td> </tr> <tr> <td> <div style="text-align: right;">0/0 0/0 3/4</div> <div style="text-align: center;">J I L</div> <div style="text-align: right;">Development C Dwy</div> </td> <td> <div style="text-align: right;">0/0 4/5 0/0</div> <div style="text-align: center;">J I L</div> <div style="text-align: right;">Development E Dwy</div> </td> </tr> </table>	<div style="text-align: right;">0/0 0/0 6/7</div> <div style="text-align: center;">J I L</div> <div style="text-align: right;">Weston Rd</div>	<div style="text-align: right;">5/6 0/0 2/3</div> <div style="text-align: center;">J I L</div> <div style="text-align: right;">Development D Dwy</div>	<div style="text-align: right;">0/0 0/0 3/4</div> <div style="text-align: center;">J I L</div> <div style="text-align: right;">Development C Dwy</div>	<div style="text-align: right;">0/0 4/5 0/0</div> <div style="text-align: center;">J I L</div> <div style="text-align: right;">Development E Dwy</div>	<table border="1"> <tr> <td> <div style="text-align: right;">0/0 0/0 0/0</div> <div style="text-align: center;">J I L</div> <div style="text-align: right;">Development C Dwy</div> </td> <td> <div style="text-align: right;">0/0 3/4 0/0</div> <div style="text-align: center;">J I L</div> <div style="text-align: right;">Norfield Rd</div> </td> </tr> <tr> <td> <div style="text-align: right;">0/0 0/0 0/0</div> <div style="text-align: center;">J I L</div> <div style="text-align: right;">Development E Dwy</div> </td> <td> <div style="text-align: right;">0/0 0/0 0/0</div> <div style="text-align: center;">J I L</div> <div style="text-align: right;">Norfield Rd</div> </td> </tr> </table>	<div style="text-align: right;">0/0 0/0 0/0</div> <div style="text-align: center;">J I L</div> <div style="text-align: right;">Development C Dwy</div>	<div style="text-align: right;">0/0 3/4 0/0</div> <div style="text-align: center;">J I L</div> <div style="text-align: right;">Norfield Rd</div>	<div style="text-align: right;">0/0 0/0 0/0</div> <div style="text-align: center;">J I L</div> <div style="text-align: right;">Development E Dwy</div>	<div style="text-align: right;">0/0 0/0 0/0</div> <div style="text-align: center;">J I L</div> <div style="text-align: right;">Norfield Rd</div>
<div style="text-align: right;">0/0 2/3 0/0</div> <div style="text-align: center;">J I L</div> <div style="text-align: right;">Weston Rd</div>	<div style="text-align: right;">0/0 3/4 3/3</div> <div style="text-align: center;">J I L</div> <div style="text-align: right;">Norfield Rd</div>																		
<div style="text-align: right;">0/0 4/5 0/0</div> <div style="text-align: center;">J I L</div> <div style="text-align: right;">Development D Dwy</div>	<div style="text-align: right;">0/0 3/4 3/4</div> <div style="text-align: center;">J I L</div> <div style="text-align: right;">Norfield Rd</div>																		
<div style="text-align: right;">6/7 0/0</div> <div style="text-align: center;">J I L</div> <div style="text-align: right;">Weston Rd</div>	<div style="text-align: right;">0/0 0/0</div> <div style="text-align: center;">J I L</div> <div style="text-align: right;">School Rd</div>																		
<div style="text-align: right;">5/6 0/0</div> <div style="text-align: center;">J I L</div> <div style="text-align: right;">Development B & C Dwy</div>	<div style="text-align: right;">0/0 0/0 0/0</div> <div style="text-align: center;">J I L</div> <div style="text-align: right;">Weston Rd</div>																		
<div style="text-align: right;">0/0 0/0 6/7</div> <div style="text-align: center;">J I L</div> <div style="text-align: right;">Weston Rd</div>	<div style="text-align: right;">5/6 0/0 2/3</div> <div style="text-align: center;">J I L</div> <div style="text-align: right;">Development D Dwy</div>																		
<div style="text-align: right;">0/0 0/0 3/4</div> <div style="text-align: center;">J I L</div> <div style="text-align: right;">Development C Dwy</div>	<div style="text-align: right;">0/0 4/5 0/0</div> <div style="text-align: center;">J I L</div> <div style="text-align: right;">Development E Dwy</div>																		
<div style="text-align: right;">0/0 0/0 0/0</div> <div style="text-align: center;">J I L</div> <div style="text-align: right;">Development C Dwy</div>	<div style="text-align: right;">0/0 3/4 0/0</div> <div style="text-align: center;">J I L</div> <div style="text-align: right;">Norfield Rd</div>																		
<div style="text-align: right;">0/0 0/0 0/0</div> <div style="text-align: center;">J I L</div> <div style="text-align: right;">Development E Dwy</div>	<div style="text-align: right;">0/0 0/0 0/0</div> <div style="text-align: center;">J I L</div> <div style="text-align: right;">Norfield Rd</div>																		
<table border="1"> <tr> <td> <div style="text-align: right;">6/7 0/0 3/4</div> <div style="text-align: center;">J I L</div> <div style="text-align: right;">Development D Dwy</div> </td> <td> <div style="text-align: right;">4/5 0/0 0/0</div> <div style="text-align: center;">J I L</div> <div style="text-align: right;">Norfield Rd</div> </td> </tr> <tr> <td> <div style="text-align: right;">7/9 0/0 0/0</div> <div style="text-align: center;">J I L</div> <div style="text-align: right;">Development F Dwy</div> </td> <td> <div style="text-align: right;">0/0 0/0 0/0</div> <div style="text-align: center;">J I L</div> <div style="text-align: right;">Norfield Rd</div> </td> </tr> </table>	<div style="text-align: right;">6/7 0/0 3/4</div> <div style="text-align: center;">J I L</div> <div style="text-align: right;">Development D Dwy</div>	<div style="text-align: right;">4/5 0/0 0/0</div> <div style="text-align: center;">J I L</div> <div style="text-align: right;">Norfield Rd</div>	<div style="text-align: right;">7/9 0/0 0/0</div> <div style="text-align: center;">J I L</div> <div style="text-align: right;">Development F Dwy</div>	<div style="text-align: right;">0/0 0/0 0/0</div> <div style="text-align: center;">J I L</div> <div style="text-align: right;">Norfield Rd</div>															
<div style="text-align: right;">6/7 0/0 3/4</div> <div style="text-align: center;">J I L</div> <div style="text-align: right;">Development D Dwy</div>	<div style="text-align: right;">4/5 0/0 0/0</div> <div style="text-align: center;">J I L</div> <div style="text-align: right;">Norfield Rd</div>																		
<div style="text-align: right;">7/9 0/0 0/0</div> <div style="text-align: center;">J I L</div> <div style="text-align: right;">Development F Dwy</div>	<div style="text-align: right;">0/0 0/0 0/0</div> <div style="text-align: center;">J I L</div> <div style="text-align: right;">Norfield Rd</div>																		

LEGEND

⊕ X/Y = AM/PM Peak Hour
Turning Movements

Development Area E

PERCENT INBOUND

Intersection 1 Weston Rd (Rt 57) @ Norfield Rd						
		SBR	SBT	SBL		
		30%	0%	0%		
EBL	0%				0%	WBR
EBT	0%				20%	WBT
EBR	0%				0%	WBL
		30%	0%	0%		
		NBL	NBT	NBR		

Intersection 2 Weston Rd (Rt 57) @ School Rd						
		SBR	SBT	SBL		
		0%	30%	0%		
EBL	0%				0%	WBR
EBT	0%				0%	WBT
EBR	0%				0%	WBL
		0%	0%	0%		
		NBL	NBT	NBR		

Intersection 3 Weston Rd (Rt 57) @ Development B,C & D Dwys						
		SBR	SBT	SBL		
		0%	30%	0%		
EBL	0%				0%	WBR
EBT	0%				0%	WBT
EBR	0%				0%	WBL
		0%	0%	0%		
		NBL	NBT	NBR		

Intersection 4 Norfield Rd @ Development C & E Dwys						
		SBR	SBT	SBL		
		0%	0%	0%		
EBL	0%				0%	WBR
EBT	0%				0%	WBT
EBR	20%				80%	WBL
		0%	0%	0%		
		NBL	NBT	NBR		

Intersection 5 Norfield Rd @ Development D & F Dwys						
		SBR	SBT	SBL		
		0%	0%	0%		
EBL	0%				0%	WBR
EBT	0%				20%	WBT
EBR	0%				0%	WBL
		0%	0%	0%		
		NBL	NBT	NBR		

PERCENT OUTBOUND

Intersection 1 Weston Rd (Rt 57) @ Norfield Rd						
		SBR	SBT	SBL		
		0%	0%	0%		
EBL	30%				0%	WBR
EBT	20%				0%	WBT
EBR	30%				0%	WBL
		0%	0%	0%		
		NBL	NBT	NBR		

Intersection 2 Weston Rd (Rt 57) @ School Rd						
		SBR	SBT	SBL		
		0%	0%	0%		
EBL	0%				0%	WBR
EBT	0%				0%	WBT
EBR	0%				0%	WBL
		0%	30%	0%		
		NBL	NBT	NBR		

Intersection 3 Weston Rd (Rt 57) @ Development B,C & D Dwys						
		SBR	SBT	SBL		
		0%	0%	0%		
EBL	0%				0%	WBR
EBT	0%				0%	WBT
EBR	0%				0%	WBL
		0%	30%	0%		
		NBL	NBT	NBR		

Intersection 4 Norfield Rd @ Development C & E Dwys						
		SBR	SBT	SBL		
		0%	0%	0%		
EBL	0%				0%	WBR
EBT	0%				0%	WBT
EBR	0%				0%	WBL
		20%	0%	80%		
		NBL	NBT	NBR		

Intersection 5 Norfield Rd @ Development D & F Dwys						
		SBR	SBT	SBL		
		0%	0%	0%		
EBL	0%				0%	WBR
EBT	20%				0%	WBT
EBR	0%				0%	WBL
		0%	0%	0%		
		NBL	NBT	NBR		

<table border="1"> <tr> <td data-bbox="151 155 321 302"> 1 2/11 0/0 J I L Weston Rd </td> <td data-bbox="321 155 474 302"> 0/0 2/7 0/0 J I L Norfield Rd </td> </tr> <tr> <td data-bbox="151 302 321 422"> 2/9 1/5 2/9 J I L Development F Dwy </td> <td data-bbox="321 302 474 422"> 2/11 0/0 0/0 J I L Norfield Rd </td> </tr> </table>	1 2/11 0/0 J I L Weston Rd	0/0 2/7 0/0 J I L Norfield Rd	2/9 1/5 2/9 J I L Development F Dwy	2/11 0/0 0/0 J I L Norfield Rd	<table border="1"> <tr> <td data-bbox="474 155 644 302"> 2 2/11 0/0 J I L Weston Rd </td> <td data-bbox="644 155 792 302"> 0/0 0/0 J I L School Rd </td> </tr> <tr> <td data-bbox="474 302 644 422"> 2/9 0/0 J I L Development B & C Dwy </td> <td data-bbox="644 302 792 422"> 0/0 0/0 0/0 J I L Development D Dwy </td> </tr> </table>	2 2/11 0/0 J I L Weston Rd	0/0 0/0 J I L School Rd	2/9 0/0 J I L Development B & C Dwy	0/0 0/0 0/0 J I L Development D Dwy	<table border="1"> <tr> <td data-bbox="792 155 963 302"> 3 0/0 2/11 0/0 J I L Weston Rd </td> <td data-bbox="963 155 1110 302"> 0/0 0/0 0/0 J I L Development C Dwy </td> </tr> <tr> <td data-bbox="792 302 963 422"> 0/0 0/0 1/7 J I L Development E Dwy </td> <td data-bbox="963 302 1110 422"> 0/0 0/0 6/29 J I L Norfield Rd </td> </tr> </table>	3 0/0 2/11 0/0 J I L Weston Rd	0/0 0/0 0/0 J I L Development C Dwy	0/0 0/0 1/7 J I L Development E Dwy	0/0 0/0 6/29 J I L Norfield Rd	<table border="1"> <tr> <td data-bbox="1110 155 1281 302"> 4 0/0 0/0 0/0 J I L Development D Dwy </td> <td data-bbox="1281 155 1432 302"> 0/0 0/0 0/0 J I L Development E Dwy </td> </tr> <tr> <td data-bbox="1110 302 1281 422"> 0/0 0/0 1/7 J I L Development E Dwy </td> <td data-bbox="1281 302 1432 422"> 1/6 0/0 4/23 J I L Norfield Rd </td> </tr> </table>	4 0/0 0/0 0/0 J I L Development D Dwy	0/0 0/0 0/0 J I L Development E Dwy	0/0 0/0 1/7 J I L Development E Dwy	1/6 0/0 4/23 J I L Norfield Rd
1 2/11 0/0 J I L Weston Rd	0/0 2/7 0/0 J I L Norfield Rd																		
2/9 1/5 2/9 J I L Development F Dwy	2/11 0/0 0/0 J I L Norfield Rd																		
2 2/11 0/0 J I L Weston Rd	0/0 0/0 J I L School Rd																		
2/9 0/0 J I L Development B & C Dwy	0/0 0/0 0/0 J I L Development D Dwy																		
3 0/0 2/11 0/0 J I L Weston Rd	0/0 0/0 0/0 J I L Development C Dwy																		
0/0 0/0 1/7 J I L Development E Dwy	0/0 0/0 6/29 J I L Norfield Rd																		
4 0/0 0/0 0/0 J I L Development D Dwy	0/0 0/0 0/0 J I L Development E Dwy																		
0/0 0/0 1/7 J I L Development E Dwy	1/6 0/0 4/23 J I L Norfield Rd																		
<table border="1"> <tr> <td data-bbox="151 422 321 569"> 5 0/0 0/0 0/0 J I L Development D Dwy </td> <td data-bbox="321 422 474 569"> 0/0 2/7 0/0 J I L Norfield Rd </td> </tr> <tr> <td data-bbox="151 569 321 688"> 0/0 1/5 0/0 J I L Development F Dwy </td> <td data-bbox="321 569 474 688"> 0/0 0/0 0/0 J I L Norfield Rd </td> </tr> </table>	5 0/0 0/0 0/0 J I L Development D Dwy	0/0 2/7 0/0 J I L Norfield Rd	0/0 1/5 0/0 J I L Development F Dwy	0/0 0/0 0/0 J I L Norfield Rd															
5 0/0 0/0 0/0 J I L Development D Dwy	0/0 2/7 0/0 J I L Norfield Rd																		
0/0 1/5 0/0 J I L Development F Dwy	0/0 0/0 0/0 J I L Norfield Rd																		

LEGEND

⊕ X/Y = AM/PM Peak Hour
 Turning Movements

Development Area F

PERCENT INBOUND

Intersection 1 Weston Rd (Rt 57) @ Norfield Rd						
		SBR	SBT	SBL		
		0%	0%	30%		
EBL	0%				0%	WBR
EBT	20%				0%	WBT
EBR	0%				0%	WBL
		0%	0%	30%		
		NBL	NBT	NBR		

Intersection 2 Weston Rd (Rt 57) @ School Rd						
		SBR	SBT	SBL		
		0%	30%	0%		
EBL	0%				0%	WBR
EBT	0%				0%	WBT
EBR	0%				0%	WBL
		0%	0%	0%		
		NBL	NBT	NBR		

Intersection 3 Weston Rd (Rt 57) @ Development B,C & D Dwys						
		SBR	SBT	SBL		
		0%	30%	0%		
EBL	0%				0%	WBR
EBT	0%				0%	WBT
EBR	0%				0%	WBL
		0%	0%	0%		
		NBL	NBT	NBR		

Intersection 4 Norfield Rd @ Development C & E Dwys						
		SBR	SBT	SBL		
		0%	0%	0%		
EBL	0%				0%	WBR
EBT	20%				0%	WBT
EBR	0%				0%	WBL
		0%	0%	0%		
		NBL	NBT	NBR		

Intersection 5 Norfield Rd @ Development D & F Dwys						
		SBR	SBT	SBL		
		0%	0%	0%		
EBL	0%				0%	WBR
EBT	0%				0%	WBT
EBR	80%				20%	WBL
		0%	0%	0%		
		NBL	NBT	NBR		

PERCENT OUTBOUND

Intersection 1 Weston Rd (Rt 57) @ Norfield Rd						
		SBR	SBT	SBL		
		0%	0%	0%		
EBL	0%				30%	WBR
EBT	0%				20%	WBT
EBR	0%				30%	WBL
		0%	0%	0%		
		NBL	NBT	NBR		

Intersection 2 Weston Rd (Rt 57) @ School Rd						
		SBR	SBT	SBL		
		0%	0%	0%		
EBL	0%				0%	WBR
EBT	0%				0%	WBT
EBR	0%				0%	WBL
		0%	30%	0%		
		NBL	NBT	NBR		

Intersection 3 Weston Rd (Rt 57) @ Development B,C & D Dwys						
		SBR	SBT	SBL		
		0%	0%	0%		
EBL	0%				0%	WBR
EBT	0%				0%	WBT
EBR	0%				0%	WBL
		0%	30%	0%		
		NBL	NBT	NBR		

Intersection 4 Norfield Rd @ Development C & E Dwys						
		SBR	SBT	SBL		
		0%	0%	0%		
EBL	0%				0%	WBR
EBT	0%				20%	WBT
EBR	0%				0%	WBL
		0%	0%	0%		
		NBL	NBT	NBR		

Intersection 5 Norfield Rd @ Development D & F Dwys						
		SBR	SBT	SBL		
		0%	0%	0%		
EBL	0%				0%	WBR
EBT	0%				0%	WBT
EBR	0%				0%	WBL
		80%	0%	20%		
		NBL	NBT	NBR		

<table border="1"> <tr> <td data-bbox="151 155 321 302"> 1 0/0 0/0 0/0 7/9 Weston Rd ┌┐┐ └┘└┘└┘ </td> <td data-bbox="321 155 475 302"> 5/8 4/5 5/8 Norfield Rd ┌┐┐ └┘└┘└┘ </td> </tr> <tr> <td data-bbox="151 302 321 422"> 0/0 5/5 0/0 JIL Development D Dwy </td> <td data-bbox="321 302 475 422"> 0/0 0/0 7/9 ┌┐┐ └┘└┘└┘ </td> </tr> </table>	1 0/0 0/0 0/0 7/9 Weston Rd ┌┐┐ └┘└┘└┘	5/8 4/5 5/8 Norfield Rd ┌┐┐ └┘└┘└┘	0/0 5/5 0/0 JIL Development D Dwy	0/0 0/0 7/9 ┌┐┐ └┘└┘└┘	<table border="1"> <tr> <td data-bbox="475 155 646 302"> 2 7/9 0/0 Weston Rd ┌┐ └┘ </td> <td data-bbox="646 155 800 302"> 0/0 0/0 School Rd ┌┐ └┘ </td> </tr> <tr> <td data-bbox="475 302 646 422"> 5/8 0/0 JIL Development B & C Dwy </td> <td data-bbox="646 302 800 422"> 0/0 0/0 0/0 JIL Development D Dwy </td> </tr> </table>	2 7/9 0/0 Weston Rd ┌┐ └┘	0/0 0/0 School Rd ┌┐ └┘	5/8 0/0 JIL Development B & C Dwy	0/0 0/0 0/0 JIL Development D Dwy	<table border="1"> <tr> <td data-bbox="800 155 971 302"> 3 0/0 7/9 0/0 Weston Rd ┌┐┐ └┘└┘└┘ </td> <td data-bbox="971 155 1125 302"> 0/0 0/0 0/0 Development D Dwy </td> </tr> <tr> <td data-bbox="800 302 971 422"> 0/0 0/0 0/0 JIL Development E Dwy </td> <td data-bbox="971 302 1125 422"> 0/0 5/8 0/0 ┌┐┐ └┘└┘└┘ </td> </tr> </table>	3 0/0 7/9 0/0 Weston Rd ┌┐┐ └┘└┘└┘	0/0 0/0 0/0 Development D Dwy	0/0 0/0 0/0 JIL Development E Dwy	0/0 5/8 0/0 ┌┐┐ └┘└┘└┘	<table border="1"> <tr> <td data-bbox="1125 155 1295 302"> 4 0/0 0/0 0/0 Development C Dwy </td> <td data-bbox="1295 155 1432 302"> 0/0 4/5 0/0 Norfield Rd ┌┐┐ └┘└┘└┘ </td> </tr> <tr> <td data-bbox="1125 302 1295 422"> 0/0 5/5 0/0 JIL Development E Dwy </td> <td data-bbox="1295 302 1432 422"> 0/0 0/0 0/0 ┌┐┐ └┘└┘└┘ </td> </tr> </table>	4 0/0 0/0 0/0 Development C Dwy	0/0 4/5 0/0 Norfield Rd ┌┐┐ └┘└┘└┘	0/0 5/5 0/0 JIL Development E Dwy	0/0 0/0 0/0 ┌┐┐ └┘└┘└┘
1 0/0 0/0 0/0 7/9 Weston Rd ┌┐┐ └┘└┘└┘	5/8 4/5 5/8 Norfield Rd ┌┐┐ └┘└┘└┘																		
0/0 5/5 0/0 JIL Development D Dwy	0/0 0/0 7/9 ┌┐┐ └┘└┘└┘																		
2 7/9 0/0 Weston Rd ┌┐ └┘	0/0 0/0 School Rd ┌┐ └┘																		
5/8 0/0 JIL Development B & C Dwy	0/0 0/0 0/0 JIL Development D Dwy																		
3 0/0 7/9 0/0 Weston Rd ┌┐┐ └┘└┘└┘	0/0 0/0 0/0 Development D Dwy																		
0/0 0/0 0/0 JIL Development E Dwy	0/0 5/8 0/0 ┌┐┐ └┘└┘└┘																		
4 0/0 0/0 0/0 Development C Dwy	0/0 4/5 0/0 Norfield Rd ┌┐┐ └┘└┘└┘																		
0/0 5/5 0/0 JIL Development E Dwy	0/0 0/0 0/0 ┌┐┐ └┘└┘└┘																		
<table border="1"> <tr> <td data-bbox="151 422 321 569"> 5 0/0 0/0 0/0 Development D Dwy </td> <td data-bbox="321 422 475 569"> 0/0 0/0 5/6 Norfield Rd ┌┐┐ └┘└┘└┘ </td> </tr> <tr> <td data-bbox="151 569 321 688"> 0/0 0/0 19/23 JIL Development F Dwy </td> <td data-bbox="321 569 475 688"> 14/21 0/0 3/5 ┌┐┐ └┘└┘└┘ </td> </tr> </table>	5 0/0 0/0 0/0 Development D Dwy	0/0 0/0 5/6 Norfield Rd ┌┐┐ └┘└┘└┘	0/0 0/0 19/23 JIL Development F Dwy	14/21 0/0 3/5 ┌┐┐ └┘└┘└┘															
5 0/0 0/0 0/0 Development D Dwy	0/0 0/0 5/6 Norfield Rd ┌┐┐ └┘└┘└┘																		
0/0 0/0 19/23 JIL Development F Dwy	14/21 0/0 3/5 ┌┐┐ └┘└┘└┘																		

LEGEND

⊕ X/Y = AM/PM Peak Hour
Turning Movements

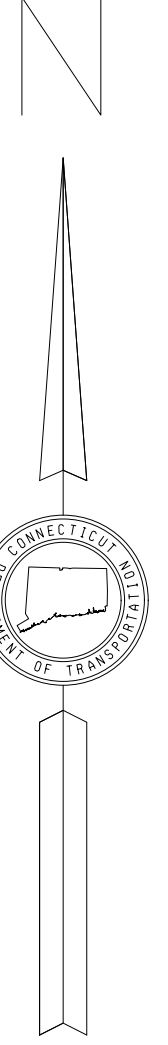

2049 Projected

000 = AM PEAK

000 = PM PEAK

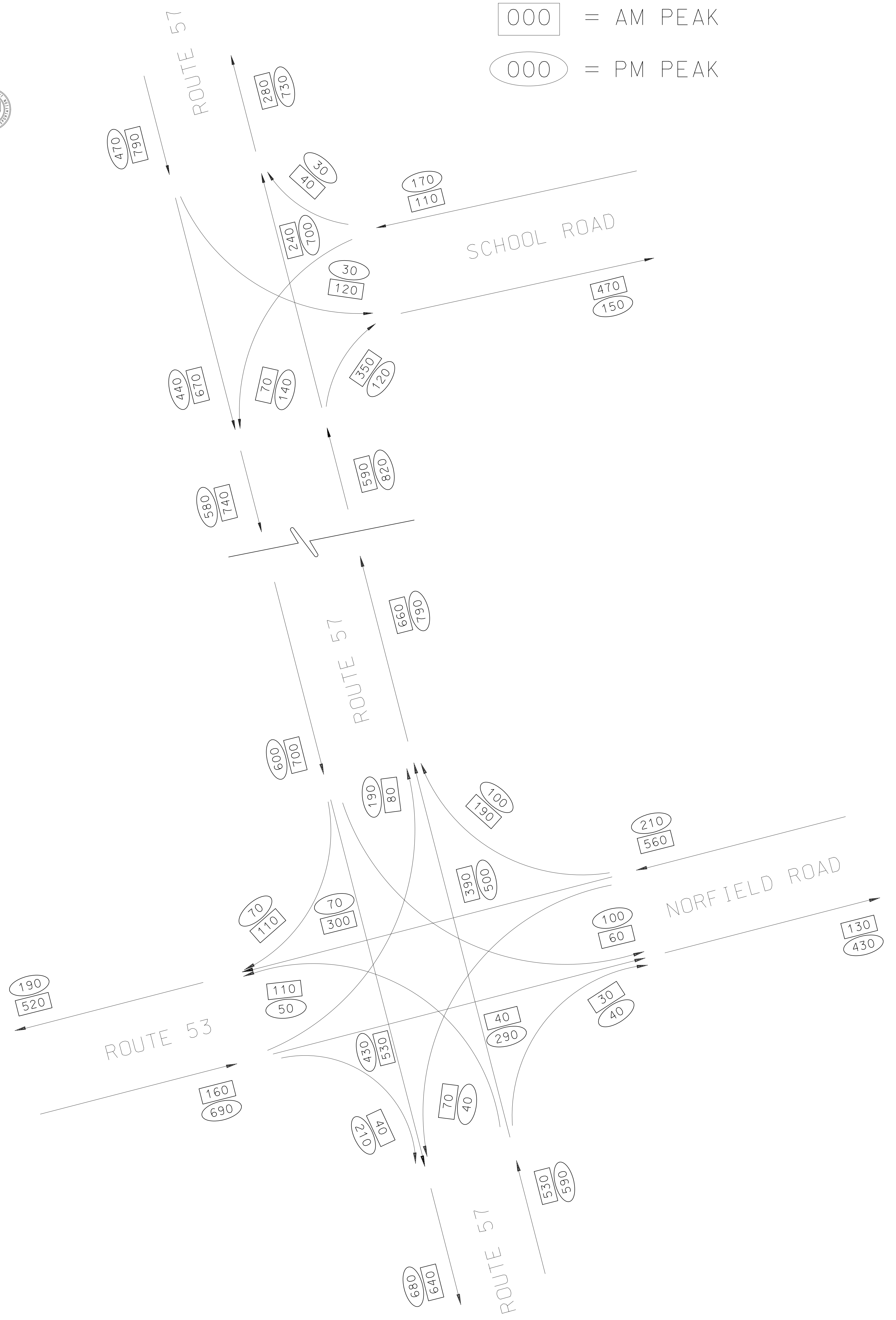

WESTON (ROUTE 57) &
SCHOOL ROAD INTERSECTION

LOTIC INTERSECTION & PEDESTRIAN SAFETY IMPROVEMENTS

WESTON, CONNECTICUT SEPTEMBER 2019



*Architecture
and Environmental Science*
98 South Main
Cheshire, Connecticut 06410
(203) 271-7773 FAX (203) 272-9733
www.miloneandmacbroom.com

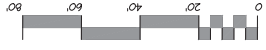

FIGURE 1



Weston Town Center
1: Weston Rd (Rt 57) & Norfield Rd

Year 2049 Plus Site
Timing Plan: AM Peak



Lane Group	EBL	EBT	EBR	WBL	WBT	WBR	NBL	NBT	NBR	SBL	SBT	SBR
Lane Configurations		↕			↕	↕		↕			↕	
Traffic Volume (vph)	90	51	43	78	310	203	113	406	40	71	541	116
Future Volume (vph)	90	51	43	78	310	203	113	406	40	71	541	116
Ideal Flow (vphpl)	1900	1900	1900	1900	1900	1900	1900	1900	1900	1900	1900	1900
Storage Length (ft)	0		0	0		50	0		0	0		0
Storage Lanes	0		0	0		1	0		0	0		0
Taper Length (ft)	25			25			25			25		
Lane Util. Factor	1.00	1.00	1.00	1.00	1.00	1.00	1.00	1.00	1.00	1.00	1.00	1.00
Ped Bike Factor		0.99			1.00	0.97		1.00			1.00	
Frt		0.968				0.850		0.990			0.978	
Flt Protected		0.976			0.990			0.990			0.995	
Satd. Flow (prot)	0	1748	0	0	1844	1583	0	1821	0	0	1806	0
Flt Permitted		0.202			0.881			0.705			0.887	
Satd. Flow (perm)	0	362	0	0	1637	1528	0	1296	0	0	1610	0
Right Turn on Red			Yes			Yes			Yes			No
Satd. Flow (RTOR)		14				116		4				
Link Speed (mph)		25			25			35			35	
Link Distance (ft)		224			275			661			337	
Travel Time (s)		6.1			7.5			12.9			6.6	
Confl. Peds. (#/hr)	5		5	5		5	5		5	5		5
Peak Hour Factor	0.92	0.92	0.92	0.92	0.92	0.92	0.92	0.92	0.92	0.92	0.92	0.92
Adj. Flow (vph)	98	55	47	85	337	221	123	441	43	77	588	126
Shared Lane Traffic (%)												
Lane Group Flow (vph)	0	200	0	0	422	221	0	607	0	0	791	0
Number of Detectors	1	2		1	2	1	1	2		1	2	
Detector Template	Left	Thru		Left	Thru	Right	Left	Thru		Left	Thru	
Leading Detector (ft)	20	100		20	100	20	20	100		20	100	
Trailing Detector (ft)	0	0		0	0	0	0	0		0	0	
Detector 1 Position(ft)	0	0		0	0	0	0	0		0	0	
Detector 1 Size(ft)	20	6		20	6	20	20	6		20	6	
Detector 1 Type	Cl+Ex	Cl+Ex		Cl+Ex	Cl+Ex	Cl+Ex	Cl+Ex	Cl+Ex		Cl+Ex	Cl+Ex	
Detector 1 Channel												
Detector 1 Extend (s)	0.0	0.0		0.0	0.0	0.0	0.0	0.0		0.0	0.0	
Detector 1 Queue (s)	0.0	0.0		0.0	0.0	0.0	0.0	0.0		0.0	0.0	
Detector 1 Delay (s)	0.0	0.0		0.0	0.0	0.0	0.0	0.0		0.0	0.0	
Detector 2 Position(ft)		94			94			94			94	
Detector 2 Size(ft)		6			6			6			6	
Detector 2 Type		Cl+Ex			Cl+Ex			Cl+Ex			Cl+Ex	
Detector 2 Channel												
Detector 2 Extend (s)		0.0			0.0			0.0			0.0	
Turn Type	D.P+P	NA		Perm	NA	Perm	Perm	NA		D.P+P	NA	
Protected Phases	4	4 5			5			2		1	1 2	
Permitted Phases	5			5		5	2			2		
Detector Phase	4	4 5		5	5	5	2	2		1	1 2	
Switch Phase												
Minimum Initial (s)	5.0			7.0	7.0	7.0	15.0	15.0		5.0		
Minimum Split (s)	9.0			22.5	22.5	22.5	24.7	24.7		9.0		
Total Split (s)	10.0			31.0	31.0	31.0	55.0	55.0		14.0		
Total Split (%)	9.1%			28.2%	28.2%	28.2%	50.0%	50.0%		12.7%		

Weston Town Center
1: Weston Rd (Rt 57) & Norfield Rd

Year 2049 Plus Site
Timing Plan: AM Peak



Lane Group	EBL	EBT	EBR	WBL	WBT	WBR	NBL	NBT	NBR	SBL	SBT	SBR
Maximum Green (s)	6.0			26.5	26.5	26.5	48.3	48.3		10.0		
Yellow Time (s)	3.0			3.5	3.5	3.5	4.2	4.2		3.0		
All-Red Time (s)	1.0			1.0	1.0	1.0	2.5	2.5		1.0		
Lost Time Adjust (s)					0.0	0.0		0.0				
Total Lost Time (s)					4.5	4.5		6.7				
Lead/Lag							Lag	Lag		Lead		
Lead-Lag Optimize?							Yes	Yes		Yes		
Vehicle Extension (s)	3.0			3.0	3.0	3.0	2.5	2.5		2.5		
Recall Mode	None			None	None	None	Min	Min		Min		
Walk Time (s)				7.0	7.0	7.0	7.0	7.0				
Flash Dont Walk (s)				11.0	11.0	11.0	11.0	11.0				
Pedestrian Calls (#/hr)				0	0	0	0	0				
Act Effect Green (s)		33.0			26.5	26.5		48.3				61.0
Actuated g/C Ratio		0.30			0.24	0.24		0.44				0.55
v/c Ratio		1.03			1.07	0.48		1.06				0.87
Control Delay		104.4			106.3	20.7		86.7				32.0
Queue Delay		0.0			0.0	0.0		0.0				0.0
Total Delay		104.4			106.3	20.7		86.7				32.0
LOS		F			F	C		F				C
Approach Delay		104.4			76.9			86.7				32.0
Approach LOS		F			E			F				C
Queue Length 50th (ft)		~102			~331	61		~473				382
Queue Length 95th (ft)		#227			#526	137		#695				#598
Internal Link Dist (ft)		144			195			581				257
Turn Bay Length (ft)						50						
Base Capacity (vph)		194			394	456		571				910
Starvation Cap Reductn		0			0	0		0				0
Spillback Cap Reductn		0			0	0		0				0
Storage Cap Reductn		0			0	0		0				0
Reduced v/c Ratio		1.03			1.07	0.48		1.06				0.87

Intersection Summary













Area Type: Other
 Cycle Length: 110
 Actuated Cycle Length: 110
 Natural Cycle: 110
 Control Type: Actuated-Uncoordinated
 Maximum v/c Ratio: 1.07
 Intersection Signal Delay: 66.2
 Intersection LOS: E
 Intersection Capacity Utilization 96.4%
 ICU Level of Service F
 Analysis Period (min) 15
 ~ Volume exceeds capacity, queue is theoretically infinite.
 Queue shown is maximum after two cycles.
 # 95th percentile volume exceeds capacity, queue may be longer.
 Queue shown is maximum after two cycles.

Splits and Phases: 1: Weston Rd (Rt 57) & Norfield Rd



Weston Town Center
2: Weston Rd (Rt 57) & School Rd

Year 2049 Plus Site
Timing Plan: AM Peak

						
Lane Group	WBL	WBR	NBT	NBR	SBL	SBT
Lane Configurations						
Traffic Volume (vph)	72	41	260	354	122	696
Future Volume (vph)	72	41	260	354	122	696
Ideal Flow (vphp)	1900	1900	1900	1900	1900	1900
Storage Length (ft)	0	0		75	50	
Storage Lanes	1	1		1	1	
Taper Length (ft)	25				25	
Lane Util. Factor	1.00	1.00	1.00	1.00	1.00	1.00
Ped Bike Factor	0.99	0.97		0.97	1.00	
Frt		0.850		0.850		
Flt Protected	0.950				0.950	
Satd. Flow (prot)	1770	1583	1863	1583	1770	1863
Flt Permitted	0.950				0.586	
Satd. Flow (perm)	1750	1535	1863	1541	1087	1863
Right Turn on Red		Yes		Yes		
Satd. Flow (RTOR)		45		385		
Link Speed (mph)	25		35			35
Link Distance (ft)	151		781			305
Travel Time (s)	4.1		15.2			5.9
Confl. Peds. (#/hr)	5	5		5	5	
Peak Hour Factor	0.92	0.92	0.92	0.92	0.92	0.92
Adj. Flow (vph)	78	45	283	385	133	757
Shared Lane Traffic (%)						
Lane Group Flow (vph)	78	45	283	385	133	757
Number of Detectors	1	1	2	1	1	2
Detector Template	Left	Right	Thru	Right	Left	Thru
Leading Detector (ft)	20	20	100	20	20	100
Trailing Detector (ft)	0	0	0	0	0	0
Detector 1 Position(ft)	0	0	0	0	0	0
Detector 1 Size(ft)	20	20	6	20	20	6
Detector 1 Type	Cl+Ex	Cl+Ex	Cl+Ex	Cl+Ex	Cl+Ex	Cl+Ex
Detector 1 Channel						
Detector 1 Extend (s)	0.0	0.0	0.0	0.0	0.0	0.0
Detector 1 Queue (s)	0.0	0.0	0.0	0.0	0.0	0.0
Detector 1 Delay (s)	0.0	0.0	0.0	0.0	0.0	0.0
Detector 2 Position(ft)			94			94
Detector 2 Size(ft)			6			6
Detector 2 Type			Cl+Ex			Cl+Ex
Detector 2 Channel						
Detector 2 Extend (s)			0.0			0.0
Turn Type	Prot	Perm	NA	Perm	D.P+P	NA
Protected Phases	4		2		1	1 2
Permitted Phases		4		2	2	
Detector Phase	4	4	2	2	1	1 2
Switch Phase						
Minimum Initial (s)	7.0	7.0	15.0	15.0	7.0	
Minimum Split (s)	20.0	20.0	30.7	30.7	10.1	
Total Split (s)	20.0	20.0	31.0	31.0	14.0	
Total Split (%)	30.8%	30.8%	47.7%	47.7%	21.5%	

Weston Town Center
2: Weston Rd (Rt 57) & School Rd

Year 2049 Plus Site
Timing Plan: AM Peak



Lane Group	WBL	WBR	NBT	NBR	SBL	SBT
Maximum Green (s)	15.0	15.0	24.3	24.3	10.9	
Yellow Time (s)	3.0	3.0	4.2	4.2	3.0	
All-Red Time (s)	2.0	2.0	2.5	2.5	0.1	
Lost Time Adjust (s)	0.0	0.0	0.0	0.0	0.0	
Total Lost Time (s)	5.0	5.0	6.7	6.7	3.1	
Lead/Lag			Lag	Lag	Lead	
Lead-Lag Optimize?			Yes	Yes	Yes	
Vehicle Extension (s)	2.0	2.0	2.5	2.5	3.0	
Recall Mode	None	None	Min	Min	Max	
Walk Time (s)	7.0	7.0	7.0	7.0		
Flash Dont Walk (s)	8.0	8.0	17.0	17.0		
Pedestrian Calls (#/hr)	0	0	0	0		
Act Effect Green (s)	7.9	7.9	19.1	19.1	34.1	38.2
Actuated g/C Ratio	0.16	0.16	0.38	0.38	0.68	0.76
v/c Ratio	0.28	0.16	0.40	0.47	0.15	0.53
Control Delay	24.3	9.8	14.2	3.7	3.2	5.5
Queue Delay	0.0	0.0	0.0	0.0	0.0	0.0
Total Delay	24.3	9.8	14.2	3.7	3.2	5.5
LOS	C	A	B	A	A	A
Approach Delay	19.0		8.1			5.1
Approach LOS	B		A			A
Queue Length 50th (ft)	21	0	62	0	9	81
Queue Length 95th (ft)	58	23	121	43	24	176
Internal Link Dist (ft)	71		701			225
Turn Bay Length (ft)				75	50	
Base Capacity (vph)	546	505	932	963	892	1542
Starvation Cap Reductn	0	0	0	0	0	0
Spillback Cap Reductn	0	0	0	0	0	0
Storage Cap Reductn	0	0	0	0	0	0
Reduced v/c Ratio	0.14	0.09	0.30	0.40	0.15	0.49

Intersection Summary

Area Type: Other
 Cycle Length: 65
 Actuated Cycle Length: 50.2
 Natural Cycle: 65
 Control Type: Actuated-Uncoordinated
 Maximum v/c Ratio: 0.53
 Intersection Signal Delay: 7.3
 Intersection LOS: A
 Intersection Capacity Utilization 51.0%
 ICU Level of Service A
 Analysis Period (min) 15

Splits and Phases: 2: Weston Rd (Rt 57) & School Rd



Weston Town Center
 3: Weston Rd (Rt 57) & Development B & C Dwy/Development D Dwy

Year 2049 Plus Site
 Timing Plan: AM Peak



Lane Group	EBL	EBT	EBR	WBL	WBT	WBR	NBL	NBT	NBR	SBL	SBT	SBR
Lane Configurations		↕			↕			↕			↕	
Traffic Volume (vph)	8	0	15	2	0	5	25	671	3	6	711	11
Future Volume (vph)	8	0	15	2	0	5	25	671	3	6	711	11
Ideal Flow (vphpl)	1900	1900	1900	1900	1900	1900	1900	1900	1900	1900	1900	1900
Lane Util. Factor	1.00	1.00	1.00	1.00	1.00	1.00	1.00	1.00	1.00	1.00	1.00	1.00
Ped Bike Factor												
Frt		0.914			0.904			0.999			0.998	
Flt Protected		0.982			0.986			0.998				
Satd. Flow (prot)	0	1672	0	0	1660	0	0	1857	0	0	1859	0
Flt Permitted		0.982			0.986			0.998				
Satd. Flow (perm)	0	1672	0	0	1660	0	0	1857	0	0	1859	0
Link Speed (mph)		30			30			35			35	
Link Distance (ft)		326			260			337			781	
Travel Time (s)		7.4			5.9			6.6			15.2	
Confl. Peds. (#/hr)							5		5	5		5
Peak Hour Factor	0.92	0.92	0.92	0.92	0.92	0.92	0.92	0.92	0.92	0.92	0.92	0.92
Adj. Flow (vph)	9	0	16	2	0	5	27	729	3	7	773	12
Shared Lane Traffic (%)												
Lane Group Flow (vph)	0	25	0	0	7	0	0	759	0	0	792	0
Sign Control		Stop			Stop			Free			Free	

Intersection Summary

Area Type:	Other
Control Type:	Unsignalized
Intersection Capacity Utilization	61.9%
Analysis Period (min)	15
	ICU Level of Service B

Weston Town Center
 3: Weston Rd (Rt 57) & Development B & C Dwy/Development D Dwy

Year 2049 Plus Site
 Timing Plan: AM Peak

Intersection												
Int Delay, s/veh	0.8											
Movement	EBL	EBT	EBR	WBL	WBT	WBR	NBL	NBT	NBR	SBL	SBT	SBR
Lane Configurations		↕			↕			↕			↕	
Traffic Vol, veh/h	8	0	15	2	0	5	25	671	3	6	711	11
Future Vol, veh/h	8	0	15	2	0	5	25	671	3	6	711	11
Conflicting Peds, #/hr	0	0	0	0	0	0	5	0	5	5	0	5
Sign Control	Stop	Stop	Stop	Stop	Stop	Stop	Free	Free	Free	Free	Free	Free
RT Channelized	-	-	None	-	-	None	-	-	None	-	-	None
Storage Length	-	-	-	-	-	-	-	-	-	-	-	-
Veh in Median Storage, #	-	0	-	-	0	-	-	0	-	-	0	-
Grade, %	-	0	-	-	0	-	-	0	-	-	0	-
Peak Hour Factor	92	92	92	92	92	92	92	92	92	92	92	92
Heavy Vehicles, %	2	2	2	2	2	2	2	2	2	2	2	2
Mvmt Flow	9	0	16	2	0	5	27	729	3	7	773	12

Major/Minor	Minor2		Minor1		Major1		Major2					
Conflicting Flow All	1585	1589	784	1591	1594	736	790	0	0	737	0	0
Stage 1	798	798	-	790	790	-	-	-	-	-	-	-
Stage 2	787	791	-	801	804	-	-	-	-	-	-	-
Critical Hdwy	7.12	6.52	6.22	7.12	6.52	6.22	4.12	-	-	4.12	-	-
Critical Hdwy Stg 1	6.12	5.52	-	6.12	5.52	-	-	-	-	-	-	-
Critical Hdwy Stg 2	6.12	5.52	-	6.12	5.52	-	-	-	-	-	-	-
Follow-up Hdwy	3.518	4.018	3.318	3.518	4.018	3.318	2.218	-	-	2.218	-	-
Pot Cap-1 Maneuver	88	108	393	87	107	419	830	-	-	869	-	-
Stage 1	380	398	-	383	402	-	-	-	-	-	-	-
Stage 2	385	401	-	378	396	-	-	-	-	-	-	-
Platoon blocked, %								-	-	-	-	-
Mov Cap-1 Maneuver	82	100	391	79	99	417	826	-	-	865	-	-
Mov Cap-2 Maneuver	82	100	-	79	99	-	-	-	-	-	-	-
Stage 1	358	390	-	360	378	-	-	-	-	-	-	-
Stage 2	359	377	-	357	388	-	-	-	-	-	-	-

Approach	EB		WB		NB		SB	
HCM Control Delay, s	30		25		0.3		0.1	
HCM LOS	D		D					

Minor Lane/Major Mvmt	NBL	NBT	NBR	EBLn1WBLn1	SBL	SBT	SBR
Capacity (veh/h)	826	-	-	169	188	865	-
HCM Lane V/C Ratio	0.033	-	-	0.148	0.04	0.008	-
HCM Control Delay (s)	9.5	0	-	30	25	9.2	0
HCM Lane LOS	A	A	-	D	D	A	A
HCM 95th %tile Q(veh)	0.1	-	-	0.5	0.1	0	-

Weston Town Center
 4: Development E Dwy/Development C Dwy & Norfield Rd

Year 2049 Plus Site
 Timing Plan: AM Peak



Lane Group	EBL	EBT	EBR	WBL	WBT	WBR	NBL	NBT	NBR	SBL	SBT	SBR
Lane Configurations		↕			↕			↕			↕	
Traffic Volume (vph)	1	177	1	6	531	2	1	0	4	2	0	1
Future Volume (vph)	1	177	1	6	531	2	1	0	4	2	0	1
Ideal Flow (vphpl)	1900	1900	1900	1900	1900	1900	1900	1900	1900	1900	1900	1900
Lane Util. Factor	1.00	1.00	1.00	1.00	1.00	1.00	1.00	1.00	1.00	1.00	1.00	1.00
Ped Bike Factor												
Frt	0.999						0.892				0.955	
Flt Protected					0.999		0.990				0.968	
Satd. Flow (prot)	0	1861	0	0	1861	0	0	1645	0	0	1722	0
Flt Permitted					0.999		0.990				0.968	
Satd. Flow (perm)	0	1861	0	0	1861	0	0	1645	0	0	1722	0
Link Speed (mph)	25				25		30				30	
Link Distance (ft)	484				224		237				202	
Travel Time (s)	13.2				6.1		5.4				4.6	
Confl. Peds. (#/hr)	5			5	5			5				
Peak Hour Factor	0.92	0.92	0.92	0.92	0.92	0.92	0.92	0.92	0.92	0.92	0.92	0.92
Adj. Flow (vph)	1	192	1	7	577	2	1	0	4	2	0	1
Shared Lane Traffic (%)												
Lane Group Flow (vph)	0	194	0	0	586	0	0	5	0	0	3	0
Sign Control	Free				Free		Stop				Stop	

Intersection Summary

Area Type:	Other
Control Type:	Unsignalized
Intersection Capacity Utilization	42.2%
Analysis Period (min)	15
	ICU Level of Service A

Weston Town Center
 4: Development E Dwy/Development C Dwy & Norfield Rd

Year 2049 Plus Site
 Timing Plan: AM Peak

Intersection												
Int Delay, s/veh	0.2											
Movement	EBL	EBT	EBR	WBL	WBT	WBR	NBL	NBT	NBR	SBL	SBT	SBR
Lane Configurations		↕			↕			↕			↕	
Traffic Vol, veh/h	1	177	1	6	531	2	1	0	4	2	0	1
Future Vol, veh/h	1	177	1	6	531	2	1	0	4	2	0	1
Conflicting Peds, #/hr	5	0	5	5	0	5	0	0	0	0	0	0
Sign Control	Free	Free	Free	Free	Free	Free	Stop	Stop	Stop	Stop	Stop	Stop
RT Channelized	-	-	None	-	-	None	-	-	None	-	-	None
Storage Length	-	-	-	-	-	-	-	-	-	-	-	-
Veh in Median Storage, #	-	0	-	-	0	-	-	0	-	-	0	-
Grade, %	-	0	-	-	0	-	-	0	-	-	0	-
Peak Hour Factor	92	92	92	92	92	92	92	92	92	92	92	92
Heavy Vehicles, %	2	2	2	2	2	2	2	2	2	2	2	2
Mvmt Flow	1	192	1	7	577	2	1	0	4	2	0	1

Major/Minor	Major1			Major2			Minor1			Minor2		
Conflicting Flow All	584	0	0	198	0	0	793	798	198	794	797	583
Stage 1	-	-	-	-	-	-	200	200	-	597	597	-
Stage 2	-	-	-	-	-	-	593	598	-	197	200	-
Critical Hdwy	4.12	-	-	4.12	-	-	7.12	6.52	6.22	7.12	6.52	6.22
Critical Hdwy Stg 1	-	-	-	-	-	-	6.12	5.52	-	6.12	5.52	-
Critical Hdwy Stg 2	-	-	-	-	-	-	6.12	5.52	-	6.12	5.52	-
Follow-up Hdwy	2.218	-	-	2.218	-	-	3.518	4.018	3.318	3.518	4.018	3.318
Pot Cap-1 Maneuver	991	-	-	1375	-	-	306	319	843	306	319	512
Stage 1	-	-	-	-	-	-	802	736	-	490	491	-
Stage 2	-	-	-	-	-	-	492	491	-	805	736	-
Platoon blocked, %		-	-		-	-						
Mov Cap-1 Maneuver	986	-	-	1368	-	-	302	313	839	301	313	510
Mov Cap-2 Maneuver	-	-	-	-	-	-	302	313	-	301	313	-
Stage 1	-	-	-	-	-	-	797	732	-	487	485	-
Stage 2	-	-	-	-	-	-	487	485	-	800	732	-

Approach	EB			WB			NB			SB		
HCM Control Delay, s	0			0.1			10.9			15.4		
HCM LOS							B			C		

Minor Lane/Major Mvmt	NBLn1	EBL	EBT	EBR	WBL	WBT	WBR	SBLn1
Capacity (veh/h)	619	986	-	-	1368	-	-	349
HCM Lane V/C Ratio	0.009	0.001	-	-	0.005	-	-	0.009
HCM Control Delay (s)	10.9	8.7	0	-	7.6	0	-	15.4
HCM Lane LOS	B	A	A	-	A	A	-	C
HCM 95th %tile Q(veh)	0	0	-	-	0	-	-	0

Weston Town Center
5: Development F Dwy/Development D Dwy & Norfield Rd

Year 2049 Plus Site
Timing Plan: AM Peak



Lane Group	EBL	EBT	EBR	WBL	WBT	WBR	NBL	NBT	NBR	SBL	SBT	SBR
Lane Configurations		↕			↕			↕			↕	
Traffic Volume (vph)	7	136	19	5	571	4	14	0	3	3	0	6
Future Volume (vph)	7	136	19	5	571	4	14	0	3	3	0	6
Ideal Flow (vphpl)	1900	1900	1900	1900	1900	1900	1900	1900	1900	1900	1900	1900
Lane Util. Factor	1.00	1.00	1.00	1.00	1.00	1.00	1.00	1.00	1.00	1.00	1.00	1.00
Ped Bike Factor												
Frt		0.984			0.999			0.977			0.905	
Flt Protected		0.998						0.960			0.985	
Satd. Flow (prot)	0	1829	0	0	1861	0	0	1747	0	0	1660	0
Flt Permitted		0.998						0.960			0.985	
Satd. Flow (perm)	0	1829	0	0	1861	0	0	1747	0	0	1660	0
Link Speed (mph)		25			25			30			30	
Link Distance (ft)		275			518			191			250	
Travel Time (s)		7.5			14.1			4.3			5.7	
Confl. Peds. (#/hr)	5		5	5		5						
Peak Hour Factor	0.92	0.92	0.92	0.92	0.92	0.92	0.92	0.92	0.92	0.92	0.92	0.92
Adj. Flow (vph)	8	148	21	5	621	4	15	0	3	3	0	7
Shared Lane Traffic (%)												
Lane Group Flow (vph)	0	177	0	0	630	0	0	18	0	0	10	0
Sign Control		Free			Free			Stop			Stop	

Intersection Summary

Area Type:	Other
Control Type:	Unsignalized
Intersection Capacity Utilization	42.0%
Analysis Period (min)	15
	ICU Level of Service A

Weston Town Center
5: Development F Dwy/Development D Dwy & Norfield Rd

Year 2049 Plus Site
Timing Plan: AM Peak

Intersection												
Int Delay, s/veh	0.7											
Movement	EBL	EBT	EBR	WBL	WBT	WBR	NBL	NBT	NBR	SBL	SBT	SBR
Lane Configurations		↕			↕			↕			↕	
Traffic Vol, veh/h	7	136	19	5	571	4	14	0	3	3	0	6
Future Vol, veh/h	7	136	19	5	571	4	14	0	3	3	0	6
Conflicting Peds, #/hr	5	0	5	5	0	5	0	0	0	0	0	0
Sign Control	Free	Free	Free	Free	Free	Free	Stop	Stop	Stop	Stop	Stop	Stop
RT Channelized	-	-	None	-	-	None	-	-	None	-	-	None
Storage Length	-	-	-	-	-	-	-	-	-	-	-	-
Veh in Median Storage, #	-	0	-	-	0	-	-	0	-	-	0	-
Grade, %	-	0	-	-	0	-	-	0	-	-	0	-
Peak Hour Factor	92	92	92	92	92	92	92	92	92	92	92	92
Heavy Vehicles, %	2	2	2	2	2	2	2	2	2	2	2	2
Mvmt Flow	8	148	21	5	621	4	15	0	3	3	0	7

Major/Minor	Major1			Major2			Minor1			Minor2		
Conflicting Flow All	630	0	0	174	0	0	817	820	164	814	828	628
Stage 1	-	-	-	-	-	-	180	180	-	638	638	-
Stage 2	-	-	-	-	-	-	637	640	-	176	190	-
Critical Hdwy	4.12	-	-	4.12	-	-	7.12	6.52	6.22	7.12	6.52	6.22
Critical Hdwy Stg 1	-	-	-	-	-	-	6.12	5.52	-	6.12	5.52	-
Critical Hdwy Stg 2	-	-	-	-	-	-	6.12	5.52	-	6.12	5.52	-
Follow-up Hdwy	2.218	-	-	2.218	-	-	3.518	4.018	3.318	3.518	4.018	3.318
Pot Cap-1 Maneuver	952	-	-	1403	-	-	295	310	881	297	306	483
Stage 1	-	-	-	-	-	-	822	750	-	465	471	-
Stage 2	-	-	-	-	-	-	465	470	-	826	743	-
Platoon blocked, %	-	-	-	-	-	-	-	-	-	-	-	-
Mov Cap-1 Maneuver	947	-	-	1396	-	-	286	303	877	291	299	481
Mov Cap-2 Maneuver	-	-	-	-	-	-	286	303	-	291	299	-
Stage 1	-	-	-	-	-	-	810	740	-	458	466	-
Stage 2	-	-	-	-	-	-	456	465	-	816	733	-

Approach	EB			WB			NB			SB		
HCM Control Delay, s	0.4			0.1			16.7			14.3		
HCM LOS							C			B		

Minor Lane/Major Mvmt	NBLn1	EBL	EBT	EBR	WBL	WBT	WBR	SBLn1
Capacity (veh/h)	325	947	-	-	1396	-	-	395
HCM Lane V/C Ratio	0.057	0.008	-	-	0.004	-	-	0.025
HCM Control Delay (s)	16.7	8.8	0	-	7.6	0	-	14.3
HCM Lane LOS	C	A	A	-	A	A	-	B
HCM 95th %tile Q(veh)	0.2	0	-	-	0	-	-	0.1

Weston Town Center
1: Weston Rd (Rt 57) & Norfield Rd

Year 2049 Plus Site
Timing Plan: PM Peak



Lane Group	EBL	EBT	EBR	WBL	WBT	WBR	NBL	NBT	NBR	SBL	SBT	SBR
Lane Configurations		↕			↕	↗		↕			↕	
Traffic Volume (vph)	198	303	216	48	83	111	59	512	50	114	445	79
Future Volume (vph)	198	303	216	48	83	111	59	512	50	114	445	79
Ideal Flow (vphpl)	1900	1900	1900	1900	1900	1900	1900	1900	1900	1900	1900	1900
Storage Length (ft)	0		0	0		50	0		0	0		0
Storage Lanes	0		0	0		1	0		0	0		0
Taper Length (ft)	25			25			25			25		
Lane Util. Factor	1.00	1.00	1.00	1.00	1.00	1.00	1.00	1.00	1.00	1.00	1.00	1.00
Ped Bike Factor		0.99			1.00	0.97		1.00			1.00	
Frt		0.959				0.850		0.989			0.983	
Flt Protected		0.986			0.982			0.995			0.991	
Satd. Flow (prot)	0	1747	0	0	1829	1583	0	1828	0	0	1809	0
Flt Permitted		0.738			0.650			0.880			0.655	
Satd. Flow (perm)	0	1304	0	0	1209	1530	0	1616	0	0	1196	0
Right Turn on Red			Yes			Yes			Yes			No
Satd. Flow (RTOR)		24				128		5				
Link Speed (mph)		25			25			35			35	
Link Distance (ft)		269			280			661			323	
Travel Time (s)		7.3			7.6			12.9			6.3	
Confl. Peds. (#/hr)	5		5	5		5	5		5	5		5
Peak Hour Factor	0.92	0.92	0.92	0.92	0.92	0.92	0.92	0.92	0.92	0.92	0.92	0.92
Adj. Flow (vph)	215	329	235	52	90	121	64	557	54	124	484	86
Shared Lane Traffic (%)												
Lane Group Flow (vph)	0	779	0	0	142	121	0	675	0	0	694	0
Number of Detectors	1	2		1	2	1	1	2		1	2	
Detector Template	Left	Thru		Left	Thru	Right	Left	Thru		Left	Thru	
Leading Detector (ft)	20	100		20	100	20	20	100		20	100	
Trailing Detector (ft)	0	0		0	0	0	0	0		0	0	
Detector 1 Position(ft)	0	0		0	0	0	0	0		0	0	
Detector 1 Size(ft)	20	6		20	6	20	20	6		20	6	
Detector 1 Type	Cl+Ex	Cl+Ex		Cl+Ex	Cl+Ex	Cl+Ex	Cl+Ex	Cl+Ex		Cl+Ex	Cl+Ex	
Detector 1 Channel												
Detector 1 Extend (s)	0.0	0.0		0.0	0.0	0.0	0.0	0.0		0.0	0.0	
Detector 1 Queue (s)	0.0	0.0		0.0	0.0	0.0	0.0	0.0		0.0	0.0	
Detector 1 Delay (s)	0.0	0.0		0.0	0.0	0.0	0.0	0.0		0.0	0.0	
Detector 2 Position(ft)		94			94			94			94	
Detector 2 Size(ft)		6			6			6			6	
Detector 2 Type		Cl+Ex			Cl+Ex			Cl+Ex			Cl+Ex	
Detector 2 Channel												
Detector 2 Extend (s)		0.0			0.0			0.0			0.0	
Turn Type	D.P+P	NA		Perm	NA	Perm	Perm	NA		D.P+P	NA	
Protected Phases	4	4 5			5			2		1	1 2	
Permitted Phases	5			5		5	2			2		
Detector Phase	4	4 5		5	5	5	2	2		1	1 2	
Switch Phase												
Minimum Initial (s)	5.0			7.0	7.0	7.0	15.0	15.0		5.0		
Minimum Split (s)	9.0			22.5	22.5	22.5	24.7	24.7		9.0		
Total Split (s)	21.0			22.5	22.5	22.5	43.5	43.5		13.0		
Total Split (%)	21.0%			22.5%	22.5%	22.5%	43.5%	43.5%		13.0%		

Weston Town Center
1: Weston Rd (Rt 57) & Norfield Rd

Year 2049 Plus Site
Timing Plan: PM Peak



Lane Group	EBL	EBT	EBR	WBL	WBT	WBR	NBL	NBT	NBR	SBL	SBT	SBR
Maximum Green (s)	17.0			18.0	18.0	18.0	36.8	36.8		9.0		
Yellow Time (s)	3.0			3.5	3.5	3.5	4.2	4.2		3.0		
All-Red Time (s)	1.0			1.0	1.0	1.0	2.5	2.5		1.0		
Lost Time Adjust (s)					0.0	0.0		0.0				
Total Lost Time (s)					4.5	4.5		6.7				
Lead/Lag							Lag	Lag		Lead		
Lead-Lag Optimize?							Yes	Yes		Yes		
Vehicle Extension (s)	3.0			3.0	3.0	3.0	2.5	2.5		2.5		
Recall Mode	None			None	None	None	Min	Min		Min		
Walk Time (s)				7.0	7.0	7.0	7.0	7.0				
Flash Dont Walk (s)				11.0	11.0	11.0	11.0	11.0				
Pedestrian Calls (#/hr)				0	0	0	0	0				
Act Effect Green (s)		35.5			18.0	18.0		36.8				48.5
Actuated g/C Ratio		0.36			0.18	0.18		0.37				0.48
v/c Ratio		1.41			0.65	0.32		1.13				1.09
Control Delay		220.7			53.8	8.4		109.5				88.5
Queue Delay		0.0			0.0	0.0		0.0				0.0
Total Delay		220.7			53.8	8.4		109.5				88.5
LOS		F			D	A		F				F
Approach Delay		220.7			32.9			109.5				88.5
Approach LOS		F			C			F				F
Queue Length 50th (ft)		-498			85	0		-502				-383
Queue Length 95th (ft)		#729			#167	44		#724				#722
Internal Link Dist (ft)		189			200			581				243
Turn Bay Length (ft)						50						
Base Capacity (vph)		553			217	380		597				635
Starvation Cap Reductn		0			0	0		0				0
Spillback Cap Reductn		0			0	0		0				0
Storage Cap Reductn		0			0	0		0				0
Reduced v/c Ratio		1.41			0.65	0.32		1.13				1.09

Intersection Summary













Area Type: Other
 Cycle Length: 100
 Actuated Cycle Length: 100
 Natural Cycle: 130
 Control Type: Actuated-Uncoordinated
 Maximum v/c Ratio: 1.41
 Intersection Signal Delay: 131.0
 Intersection LOS: F
 Intersection Capacity Utilization 111.1%
 ICU Level of Service H
 Analysis Period (min) 15
 ~ Volume exceeds capacity, queue is theoretically infinite.
 Queue shown is maximum after two cycles.
 # 95th percentile volume exceeds capacity, queue may be longer.
 Queue shown is maximum after two cycles.

Splits and Phases: 1: Weston Rd (Rt 57) & Norfield Rd



Weston Town Center
2: Weston Rd (Rt 57) & School Rd

Year 2049 Plus Site
Timing Plan: PM Peak

						
Lane Group	WBL	WBR	NBT	NBR	SBL	SBT
Lane Configurations						
Traffic Volume (vph)	145	32	726	123	32	470
Future Volume (vph)	145	32	726	123	32	470
Ideal Flow (vphp)	1900	1900	1900	1900	1900	1900
Storage Length (ft)	0	0		75	50	
Storage Lanes	1	1		1	1	
Taper Length (ft)	25				25	
Lane Util. Factor	1.00	1.00	1.00	1.00	1.00	1.00
Ped Bike Factor	0.99	0.97		0.97	1.00	
Frt		0.850		0.850		
Flt Protected	0.950				0.950	
Satd. Flow (prot)	1770	1583	1863	1583	1770	1863
Flt Permitted	0.950				0.156	
Satd. Flow (perm)	1749	1534	1863	1540	290	1863
Right Turn on Red		Yes		Yes		
Satd. Flow (RTOR)		35		66		
Link Speed (mph)	25		35			35
Link Distance (ft)	151		794			305
Travel Time (s)	4.1		15.5			5.9
Confl. Peds. (#/hr)	5	5		5	5	
Peak Hour Factor	0.92	0.92	0.92	0.92	0.92	0.92
Adj. Flow (vph)	158	35	789	134	35	511
Shared Lane Traffic (%)						
Lane Group Flow (vph)	158	35	789	134	35	511
Number of Detectors	1	1	2	1	1	2
Detector Template	Left	Right	Thru	Right	Left	Thru
Leading Detector (ft)	20	20	100	20	20	100
Trailing Detector (ft)	0	0	0	0	0	0
Detector 1 Position(ft)	0	0	0	0	0	0
Detector 1 Size(ft)	20	20	6	20	20	6
Detector 1 Type	Cl+Ex	Cl+Ex	Cl+Ex	Cl+Ex	Cl+Ex	Cl+Ex
Detector 1 Channel						
Detector 1 Extend (s)	0.0	0.0	0.0	0.0	0.0	0.0
Detector 1 Queue (s)	0.0	0.0	0.0	0.0	0.0	0.0
Detector 1 Delay (s)	0.0	0.0	0.0	0.0	0.0	0.0
Detector 2 Position(ft)			94			94
Detector 2 Size(ft)			6			6
Detector 2 Type			Cl+Ex			Cl+Ex
Detector 2 Channel						
Detector 2 Extend (s)			0.0			0.0
Turn Type	Prot	Perm	NA	Perm	D.P+P	NA
Protected Phases	4		2		1	1 2
Permitted Phases		4		2	2	
Detector Phase	4	4	2	2	1	1 2
Switch Phase						
Minimum Initial (s)	7.0	7.0	15.0	15.0	7.0	
Minimum Split (s)	20.0	20.0	30.7	30.7	10.1	
Total Split (s)	20.0	20.0	39.8	39.8	10.2	
Total Split (%)	28.6%	28.6%	56.9%	56.9%	14.6%	

Weston Town Center
2: Weston Rd (Rt 57) & School Rd

Year 2049 Plus Site
Timing Plan: PM Peak



Lane Group	WBL	WBR	NBT	NBR	SBL	SBT
Maximum Green (s)	15.0	15.0	33.1	33.1	7.1	
Yellow Time (s)	3.0	3.0	4.2	4.2	3.0	
All-Red Time (s)	2.0	2.0	2.5	2.5	0.1	
Lost Time Adjust (s)	0.0	0.0	0.0	0.0	0.0	
Total Lost Time (s)	5.0	5.0	6.7	6.7	3.1	
Lead/Lag			Lag	Lag	Lead	
Lead-Lag Optimize?			Yes	Yes	Yes	
Vehicle Extension (s)	2.0	2.0	2.5	2.5	3.0	
Recall Mode	None	None	Min	Min	Max	
Walk Time (s)	7.0	7.0	7.0	7.0		
Flash Dont Walk (s)	8.0	8.0	17.0	17.0		
Pedestrian Calls (#/hr)	0	0	0	0		
Act Effect Green (s)	10.6	10.6	29.9	29.9	41.3	45.7
Actuated g/C Ratio	0.18	0.18	0.50	0.50	0.69	0.77
v/c Ratio	0.50	0.12	0.85	0.17	0.09	0.36
Control Delay	31.0	9.8	25.5	6.2	3.9	4.8
Queue Delay	0.0	0.0	0.0	0.0	0.0	0.0
Total Delay	31.0	9.8	25.5	6.2	3.9	4.8
LOS	C	A	C	A	A	A
Approach Delay	27.2		22.7			4.7
Approach LOS	C		C			A
Queue Length 50th (ft)	59	0	248	13	3	60
Queue Length 95th (ft)	111	21	#521	43	12	133
Internal Link Dist (ft)	71		714			225
Turn Bay Length (ft)				75	50	
Base Capacity (vph)	475	437	1103	939	388	1435
Starvation Cap Reductn	0	0	0	0	0	0
Spillback Cap Reductn	0	0	0	0	0	0
Storage Cap Reductn	0	0	0	0	0	0
Reduced v/c Ratio	0.33	0.08	0.72	0.14	0.09	0.36

Intersection Summary

Area Type: Other
 Cycle Length: 70
 Actuated Cycle Length: 59.7
 Natural Cycle: 70
 Control Type: Actuated-Uncoordinated
 Maximum v/c Ratio: 0.85
 Intersection Signal Delay: 17.3
 Intersection LOS: B
 Intersection Capacity Utilization 56.7%
 ICU Level of Service B
 Analysis Period (min) 15

95th percentile volume exceeds capacity, queue may be longer.
 Queue shown is maximum after two cycles.

Splits and Phases: 2: Weston Rd (Rt 57) & School Rd



Weston Town Center
 3: Weston Rd (Rt 57) & Development B & C Dwy/Development D Dwy

Year 2049 Plus Site
 Timing Plan: PM Peak



Lane Group	EBL	EBT	EBR	WBL	WBT	WBR	NBL	NBT	NBR	SBL	SBT	SBR
Lane Configurations		↕			↕			↕			↕	
Traffic Volume (vph)	14	0	22	2	0	5	19	800	3	6	614	15
Future Volume (vph)	14	0	22	2	0	5	19	800	3	6	614	15
Ideal Flow (vphpl)	1900	1900	1900	1900	1900	1900	1900	1900	1900	1900	1900	1900
Lane Util. Factor	1.00	1.00	1.00	1.00	1.00	1.00	1.00	1.00	1.00	1.00	1.00	1.00
Ped Bike Factor												
Frt		0.917			0.904							0.997
Flt Protected		0.981			0.986			0.999				0.999
Satd. Flow (prot)	0	1676	0	0	1660	0	0	1861	0	0	1855	0
Flt Permitted		0.981			0.986			0.999				0.999
Satd. Flow (perm)	0	1676	0	0	1660	0	0	1861	0	0	1855	0
Link Speed (mph)		30			30			35				35
Link Distance (ft)		223			234			323				794
Travel Time (s)		5.1			5.3			6.3				15.5
Confl. Peds. (#/hr)							5		5	5		5
Peak Hour Factor	0.92	0.92	0.92	0.92	0.92	0.92	0.92	0.92	0.92	0.92	0.92	0.92
Adj. Flow (vph)	15	0	24	2	0	5	21	870	3	7	667	16
Shared Lane Traffic (%)												
Lane Group Flow (vph)	0	39	0	0	7	0	0	894	0	0	690	0
Sign Control		Stop			Stop			Free			Free	

Intersection Summary

Area Type:	Other
Control Type:	Unsignalized
Intersection Capacity Utilization	64.3%
Analysis Period (min)	15
	ICU Level of Service C

Weston Town Center
 3: Weston Rd (Rt 57) & Development B & C Dwy/Development D Dwy

Year 2049 Plus Site
 Timing Plan: PM Peak

Intersection												
Int Delay, s/veh	1.1											
Movement	EBL	EBT	EBR	WBL	WBT	WBR	NBL	NBT	NBR	SBL	SBT	SBR
Lane Configurations		↕			↕			↕			↕	
Traffic Vol, veh/h	14	0	22	2	0	5	19	800	3	6	614	15
Future Vol, veh/h	14	0	22	2	0	5	19	800	3	6	614	15
Conflicting Peds, #/hr	0	0	0	0	0	0	5	0	5	5	0	5
Sign Control	Stop	Stop	Stop	Stop	Stop	Stop	Free	Free	Free	Free	Free	Free
RT Channelized	-	-	None	-	-	None	-	-	None	-	-	None
Storage Length	-	-	-	-	-	-	-	-	-	-	-	-
Veh in Median Storage, #	-	0	-	-	0	-	-	0	-	-	0	-
Grade, %	-	0	-	-	0	-	-	0	-	-	0	-
Peak Hour Factor	92	92	92	92	92	92	92	92	92	92	92	92
Heavy Vehicles, %	2	2	2	2	2	2	2	2	2	2	2	2
Mvmt Flow	15	0	24	2	0	5	21	870	3	7	667	16

Major/Minor	Minor2		Minor1		Major1		Major2					
Conflicting Flow All	1610	1614	680	1620	1621	877	688	0	0	878	0	0
Stage 1	694	694	-	919	919	-	-	-	-	-	-	-
Stage 2	916	920	-	701	702	-	-	-	-	-	-	-
Critical Hdwy	7.12	6.52	6.22	7.12	6.52	6.22	4.12	-	-	4.12	-	-
Critical Hdwy Stg 1	6.12	5.52	-	6.12	5.52	-	-	-	-	-	-	-
Critical Hdwy Stg 2	6.12	5.52	-	6.12	5.52	-	-	-	-	-	-	-
Follow-up Hdwy	3.518	4.018	3.318	3.518	4.018	3.318	2.218	-	-	2.218	-	-
Pot Cap-1 Maneuver	84	104	451	83	103	348	906	-	-	769	-	-
Stage 1	433	444	-	325	350	-	-	-	-	-	-	-
Stage 2	326	350	-	429	440	-	-	-	-	-	-	-
Platoon blocked, %								-	-	-	-	-
Mov Cap-1 Maneuver	79	97	449	75	96	346	902	-	-	765	-	-
Mov Cap-2 Maneuver	79	97	-	75	96	-	-	-	-	-	-	-
Stage 1	411	435	-	309	333	-	-	-	-	-	-	-
Stage 2	306	333	-	400	431	-	-	-	-	-	-	-

Approach	EB		WB		NB		SB	
HCM Control Delay, s	34.9		27.2		0.2		0.1	
HCM LOS	D		D					

Minor Lane/Major Mvmt	NBL	NBT	NBR	EBLn1WBLn1	SBL	SBT	SBR
Capacity (veh/h)	902	-	-	159	170	765	-
HCM Lane V/C Ratio	0.023	-	-	0.246	0.045	0.009	-
HCM Control Delay (s)	9.1	0	-	34.9	27.2	9.7	0
HCM Lane LOS	A	A	-	D	D	A	A
HCM 95th %tile Q(veh)	0.1	-	-	0.9	0.1	0	-

Weston Town Center
 4: Development E Dwy/Development C Dwy & Norfield Rd

Year 2049 Plus Site
 Timing Plan: PM Peak



Lane Group	EBL	EBT	EBR	WBL	WBT	WBR	NBL	NBT	NBR	SBL	SBT	SBR
Lane Configurations		↕			↕			↕			↕	
Traffic Volume (vph)	4	705	1	6	204	11	1	0	4	7	0	3
Future Volume (vph)	4	705	1	6	204	11	1	0	4	7	0	3
Ideal Flow (vphpl)	1900	1900	1900	1900	1900	1900	1900	1900	1900	1900	1900	1900
Lane Util. Factor	1.00	1.00	1.00	1.00	1.00	1.00	1.00	1.00	1.00	1.00	1.00	1.00
Ped Bike Factor												
Frt					0.993			0.892			0.963	
Flt Protected					0.999			0.990			0.965	
Satd. Flow (prot)	0	1863	0	0	1848	0	0	1645	0	0	1731	0
Flt Permitted					0.999			0.990			0.965	
Satd. Flow (perm)	0	1863	0	0	1848	0	0	1645	0	0	1731	0
Link Speed (mph)		25			25			30			30	
Link Distance (ft)		582			269			182			196	
Travel Time (s)		15.9			7.3			4.1			4.5	
Confl. Peds. (#/hr)	5		5	5		5						
Peak Hour Factor	0.92	0.92	0.92	0.92	0.92	0.92	0.92	0.92	0.92	0.92	0.92	0.92
Adj. Flow (vph)	4	766	1	7	222	12	1	0	4	8	0	3
Shared Lane Traffic (%)												
Lane Group Flow (vph)	0	771	0	0	241	0	0	5	0	0	11	0
Sign Control		Free			Free			Stop			Stop	

Intersection Summary

Area Type:	Other
Control Type:	Unsignalized
Intersection Capacity Utilization	48.9%
Analysis Period (min)	15
	ICU Level of Service A

Weston Town Center
4: Development E Dwy/Development C Dwy & Norfield Rd

Year 2049 Plus Site
Timing Plan: PM Peak

Intersection												
Int Delay, s/veh	0.4											
Movement	EBL	EBT	EBR	WBL	WBT	WBR	NBL	NBT	NBR	SBL	SBT	SBR
Lane Configurations		↕			↕			↕			↕	
Traffic Vol, veh/h	4	705	1	6	204	11	1	0	4	7	0	3
Future Vol, veh/h	4	705	1	6	204	11	1	0	4	7	0	3
Conflicting Peds, #/hr	5	0	5	5	0	5	0	0	0	0	0	0
Sign Control	Free	Free	Free	Free	Free	Free	Stop	Stop	Stop	Stop	Stop	Stop
RT Channelized	-	-	None	-	-	None	-	-	None	-	-	None
Storage Length	-	-	-	-	-	-	-	-	-	-	-	-
Veh in Median Storage, #	-	0	-	-	0	-	-	0	-	-	0	-
Grade, %	-	0	-	-	0	-	-	0	-	-	0	-
Peak Hour Factor	92	92	92	92	92	92	92	92	92	92	92	92
Heavy Vehicles, %	2	2	2	2	2	2	2	2	2	2	2	2
Mvmt Flow	4	766	1	7	222	12	1	0	4	8	0	3

Major/Minor	Major1			Major2			Minor1			Minor2		
Conflicting Flow All	239	0	0	772	0	0	1024	1033	772	1024	1027	233
Stage 1	-	-	-	-	-	-	780	780	-	247	247	-
Stage 2	-	-	-	-	-	-	244	253	-	777	780	-
Critical Hdwy	4.12	-	-	4.12	-	-	7.12	6.52	6.22	7.12	6.52	6.22
Critical Hdwy Stg 1	-	-	-	-	-	-	6.12	5.52	-	6.12	5.52	-
Critical Hdwy Stg 2	-	-	-	-	-	-	6.12	5.52	-	6.12	5.52	-
Follow-up Hdwy	2.218	-	-	2.218	-	-	3.518	4.018	3.318	3.518	4.018	3.318
Pot Cap-1 Maneuver	1328	-	-	843	-	-	214	232	400	214	234	806
Stage 1	-	-	-	-	-	-	388	406	-	757	702	-
Stage 2	-	-	-	-	-	-	760	698	-	390	406	-
Platoon blocked, %	-	-	-	-	-	-	-	-	-	-	-	-
Mov Cap-1 Maneuver	1322	-	-	839	-	-	210	226	398	208	228	802
Mov Cap-2 Maneuver	-	-	-	-	-	-	210	226	-	208	228	-
Stage 1	-	-	-	-	-	-	384	402	-	749	691	-
Stage 2	-	-	-	-	-	-	749	688	-	384	402	-

Approach	EB			WB			NB			SB		
HCM Control Delay, s	0			0.3			15.8			19.1		
HCM LOS							C			C		

Minor Lane/Major Mvmt	NBLn1	EBL	EBT	EBR	WBL	WBT	WBR	SBLn1
Capacity (veh/h)	338	1322	-	-	839	-	-	267
HCM Lane V/C Ratio	0.016	0.003	-	-	0.008	-	-	0.041
HCM Control Delay (s)	15.8	7.7	0	-	9.3	0	-	19.1
HCM Lane LOS	C	A	A	-	A	A	-	C
HCM 95th %tile Q(veh)	0	0	-	-	0	-	-	0.1

Weston Town Center
5: Development F Dwy/Development D Dwy & Norfield Rd

Year 2049 Plus Site
Timing Plan: PM Peak



Lane Group	EBL	EBT	EBR	WBL	WBT	WBR	NBL	NBT	NBR	SBL	SBT	SBR
Lane Configurations		↕			↕			↕			↕	
Traffic Volume (vph)	7	441	19	5	222	4	14	0	3	3	0	6
Future Volume (vph)	7	441	19	5	222	4	14	0	3	3	0	6
Ideal Flow (vphpl)	1900	1900	1900	1900	1900	1900	1900	1900	1900	1900	1900	1900
Lane Util. Factor	1.00	1.00	1.00	1.00	1.00	1.00	1.00	1.00	1.00	1.00	1.00	1.00
Ped Bike Factor												
Frt		0.994			0.998			0.977			0.905	
Flt Protected		0.999			0.999			0.960			0.985	
Satd. Flow (prot)	0	1850	0	0	1857	0	0	1747	0	0	1660	0
Flt Permitted		0.999			0.999			0.960			0.985	
Satd. Flow (perm)	0	1850	0	0	1857	0	0	1747	0	0	1660	0
Link Speed (mph)		25			25			30			30	
Link Distance (ft)		280			373			157			182	
Travel Time (s)		7.6			10.2			3.6			4.1	
Confl. Peds. (#/hr)	5		5	5		5						
Peak Hour Factor	0.92	0.92	0.92	0.92	0.92	0.92	0.92	0.92	0.92	0.92	0.92	0.92
Adj. Flow (vph)	8	479	21	5	241	4	15	0	3	3	0	7
Shared Lane Traffic (%)												
Lane Group Flow (vph)	0	508	0	0	250	0	0	18	0	0	10	0
Sign Control		Free			Free			Stop			Stop	

Intersection Summary

Area Type:	Other
Control Type:	Unsignalized
Intersection Capacity Utilization	37.8%
Analysis Period (min)	15
	ICU Level of Service A

Weston Town Center
5: Development F Dwy/Development D Dwy & Norfield Rd

Year 2049 Plus Site
Timing Plan: PM Peak

Intersection												
Int Delay, s/veh	0.7											
Movement	EBL	EBT	EBR	WBL	WBT	WBR	NBL	NBT	NBR	SBL	SBT	SBR
Lane Configurations		↕			↕			↕			↕	
Traffic Vol, veh/h	7	441	19	5	222	4	14	0	3	3	0	6
Future Vol, veh/h	7	441	19	5	222	4	14	0	3	3	0	6
Conflicting Peds, #/hr	5	0	5	5	0	5	0	0	0	0	0	0
Sign Control	Free	Free	Free	Free	Free	Free	Stop	Stop	Stop	Stop	Stop	Stop
RT Channelized	-	-	None	-	-	None	-	-	None	-	-	None
Storage Length	-	-	-	-	-	-	-	-	-	-	-	-
Veh in Median Storage, #	-	0	-	-	0	-	-	0	-	-	0	-
Grade, %	-	0	-	-	0	-	-	0	-	-	0	-
Peak Hour Factor	92	92	92	92	92	92	92	92	92	92	92	92
Heavy Vehicles, %	2	2	2	2	2	2	2	2	2	2	2	2
Mvmt Flow	8	479	21	5	241	4	15	0	3	3	0	7

Major/Minor	Major1			Major2			Minor1			Minor2		
Conflicting Flow All	250	0	0	505	0	0	768	771	495	765	779	248
Stage 1	-	-	-	-	-	-	511	511	-	258	258	-
Stage 2	-	-	-	-	-	-	257	260	-	507	521	-
Critical Hdwy	4.12	-	-	4.12	-	-	7.12	6.52	6.22	7.12	6.52	6.22
Critical Hdwy Stg 1	-	-	-	-	-	-	6.12	5.52	-	6.12	5.52	-
Critical Hdwy Stg 2	-	-	-	-	-	-	6.12	5.52	-	6.12	5.52	-
Follow-up Hdwy	2.218	-	-	2.218	-	-	3.518	4.018	3.318	3.518	4.018	3.318
Pot Cap-1 Maneuver	1316	-	-	1060	-	-	319	331	575	320	327	791
Stage 1	-	-	-	-	-	-	545	537	-	747	694	-
Stage 2	-	-	-	-	-	-	748	693	-	548	532	-
Platoon blocked, %	-	-	-	-	-	-	-	-	-	-	-	-
Mov Cap-1 Maneuver	1310	-	-	1055	-	-	312	323	572	314	319	787
Mov Cap-2 Maneuver	-	-	-	-	-	-	312	323	-	314	319	-
Stage 1	-	-	-	-	-	-	538	530	-	737	687	-
Stage 2	-	-	-	-	-	-	738	686	-	541	525	-

Approach	EB			WB			NB			SB		
HCM Control Delay, s	0.1			0.2			16.2			12		
HCM LOS							C			B		

Minor Lane/Major Mvmt	NBLn1	EBL	EBT	EBR	WBL	WBT	WBR	SBLn1
Capacity (veh/h)	339	1310	-	-	1055	-	-	524
HCM Lane V/C Ratio	0.055	0.006	-	-	0.005	-	-	0.019
HCM Control Delay (s)	16.2	7.8	0	-	8.4	0	-	12
HCM Lane LOS	C	A	A	-	A	A	-	B
HCM 95th %tile Q(veh)	0.2	0	-	-	0	-	-	0.1

Weston Town Center
1: Weston Rd (Rt 57) & Norfield Rd

Year 2049 Plus Site ADD
Timing Plan: AM Peak



Lane Group	EBL	EBT	EBR	WBL	WBT	WBR	NBL	NBT	NBR	SBL	SBT	SBR
Lane Configurations												
Traffic Volume (vph)	90	51	43	78	310	203	113	406	40	71	541	116
Future Volume (vph)	90	51	43	78	310	203	113	406	40	71	541	116
Ideal Flow (vphp)	1900	1900	1900	1900	1900	1900	1900	1900	1900	1900	1900	1900
Storage Length (ft)	100		100	100		60	100		75	100		0
Storage Lanes	1		0	1		0	1		0	1		0
Taper Length (ft)	25			25			25			25		
Lane Util. Factor	1.00	1.00	1.00	1.00	1.00	1.00	1.00	1.00	1.00	1.00	1.00	1.00
Ped Bike Factor	1.00	0.99		0.99	0.99		1.00	1.00		1.00	1.00	
Frt		0.931			0.941			0.987				0.974
Flt Protected	0.950			0.950			0.950			0.950		
Satd. Flow (prot)	1770	1712	0	1770	1734	0	1770	1834	0	1770	1806	0
Flt Permitted	0.226			0.691			0.176			0.373		
Satd. Flow (perm)	420	1712	0	1279	1734	0	327	1834	0	693	1806	0
Right Turn on Red			Yes			Yes			Yes			No
Satd. Flow (RTOR)		47			66			13				
Link Speed (mph)		25			25			35				35
Link Distance (ft)		242			275			661				337
Travel Time (s)		6.6			7.5			12.9				6.6
Confl. Peds. (#/hr)	5		5	5		5	5		5	5		5
Peak Hour Factor	0.92	0.92	0.92	0.92	0.92	0.92	0.92	0.92	0.92	0.92	0.92	0.92
Adj. Flow (vph)	98	55	47	85	337	221	123	441	43	77	588	126
Shared Lane Traffic (%)												
Lane Group Flow (vph)	98	102	0	85	558	0	123	484	0	77	714	0
Number of Detectors	1	2		1	2		1	2		1	2	
Detector Template	Left	Thru		Left	Thru		Left	Thru		Left	Thru	
Leading Detector (ft)	20	100		20	100		20	100		20	100	
Trailing Detector (ft)	0	0		0	0		0	0		0	0	
Detector 1 Position(ft)	0	0		0	0		0	0		0	0	
Detector 1 Size(ft)	20	6		20	6		20	6		20	6	
Detector 1 Type	Cl+Ex	Cl+Ex		Cl+Ex	Cl+Ex		Cl+Ex	Cl+Ex		Cl+Ex	Cl+Ex	
Detector 1 Channel												
Detector 1 Extend (s)	0.0	0.0		0.0	0.0		0.0	0.0		0.0	0.0	
Detector 1 Queue (s)	0.0	0.0		0.0	0.0		0.0	0.0		0.0	0.0	
Detector 1 Delay (s)	0.0	0.0		0.0	0.0		0.0	0.0		0.0	0.0	
Detector 2 Position(ft)		94			94			94			94	
Detector 2 Size(ft)		6			6			6			6	
Detector 2 Type		Cl+Ex			Cl+Ex			Cl+Ex			Cl+Ex	
Detector 2 Channel												
Detector 2 Extend (s)		0.0			0.0			0.0			0.0	
Turn Type	Perm	NA		Perm	NA		Perm	NA		Perm	NA	
Protected Phases		8			4			2			5	
Permitted Phases	8			4			2			5		
Detector Phase	8	8		4	4		2	2		5	5	
Switch Phase												
Minimum Initial (s)	5.0	5.0		5.0	5.0		5.0	5.0		5.0	5.0	
Minimum Split (s)	22.0	22.0		22.0	22.0		30.7	30.7		28.0	28.0	
Total Split (s)	23.0	23.0		23.0	23.0		32.0	32.0		32.0	32.0	
Total Split (%)	41.8%	41.8%		41.8%	41.8%		58.2%	58.2%		58.2%	58.2%	

Weston Town Center
1: Weston Rd (Rt 57) & Norfield Rd

Year 2049 Plus Site ADD
Timing Plan: AM Peak



Lane Group	EBL	EBT	EBR	WBL	WBT	WBR	NBL	NBT	NBR	SBL	SBT	SBR
Maximum Green (s)	19.0	19.0		19.0	19.0		28.0	28.0		28.0	28.0	
Yellow Time (s)	3.0	3.0		3.0	3.0		3.0	3.0		3.0	3.0	
All-Red Time (s)	1.0	1.0		1.0	1.0		1.0	1.0		1.0	1.0	
Lost Time Adjust (s)	0.0	0.0		0.0	0.0		0.0	0.0		0.0	0.0	
Total Lost Time (s)	4.0	4.0		4.0	4.0		4.0	4.0		4.0	4.0	
Lead/Lag												
Lead-Lag Optimize?												
Vehicle Extension (s)	3.0	3.0		3.0	3.0		2.5	2.5		2.5	2.5	
Recall Mode	Min	Min		Min	Min		Min	Min		Min	Min	
Walk Time (s)	7.0	7.0		7.0	7.0		7.0	7.0		7.0	7.0	
Flash Dont Walk (s)	11.0	11.0		11.0	11.0		11.0	11.0		11.0	11.0	
Pedestrian Calls (#/hr)	0	0		0	0		0	0		0	0	
Act Effect Green (s)	17.6	17.6		17.6	17.6		23.3	23.3		23.3	23.3	
Actuated g/C Ratio	0.36	0.36		0.36	0.36		0.47	0.47		0.47	0.47	
v/c Ratio	0.65	0.16		0.19	0.84		0.80	0.55		0.24	0.84	
Control Delay	41.2	8.4		13.7	28.8		51.9	11.8		9.9	22.1	
Queue Delay	0.0	0.0		0.0	0.0		0.0	0.0		0.0	0.0	
Total Delay	41.2	8.4		13.7	28.8		51.9	11.8		9.9	22.1	
LOS	D	A		B	C		D	B		A	C	
Approach Delay		24.5			26.8			19.9			20.9	
Approach LOS		C			C			B			C	
Queue Length 50th (ft)	26	12		18	143		29	93		13	172	
Queue Length 95th (ft)	#95	38		46	#316		#114	161		34	#357	
Internal Link Dist (ft)		162			195			581			257	
Turn Bay Length (ft)	100			100			100			100		
Base Capacity (vph)	168	712		510	732		192	1085		407	1063	
Starvation Cap Reductn	0	0		0	0		0	0		0	0	
Spillback Cap Reductn	0	0		0	0		0	0		0	0	
Storage Cap Reductn	0	0		0	0		0	0		0	0	
Reduced v/c Ratio	0.58	0.14		0.17	0.76		0.64	0.45		0.19	0.67	

Intersection Summary

Area Type: Other
 Cycle Length: 55
 Actuated Cycle Length: 49.2
 Natural Cycle: 55
 Control Type: Actuated-Uncoordinated
 Maximum v/c Ratio: 0.84
 Intersection Signal Delay: 22.7 Intersection LOS: C
 Intersection Capacity Utilization 89.1% ICU Level of Service E
 Analysis Period (min) 15
 # 95th percentile volume exceeds capacity, queue may be longer.
 Queue shown is maximum after two cycles.

Splits and Phases: 1: Weston Rd (Rt 57) & Norfield Rd

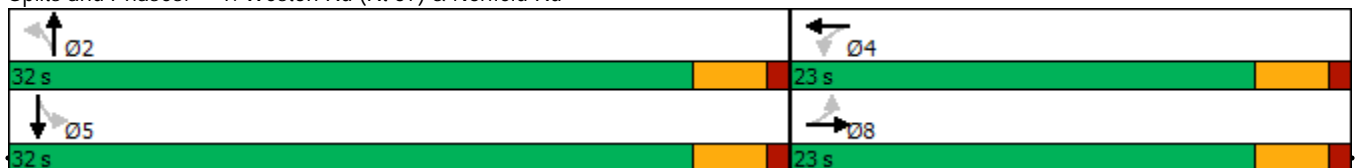

Weston Town Center
1: Weston Rd (Rt 57) & Norfield Rd

Year 2049 Plus Site ADD

Timing Plan: PM Peak

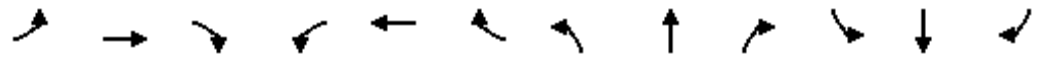

Lane Group	EBL	EBT	EBR	WBL	WBT	WBR	NBL	NBT	NBR	SBL	SBT	SBR
Lane Configurations												
Traffic Volume (vph)	198	303	216	48	83	111	59	512	50	114	445	79
Future Volume (vph)	198	303	216	48	83	111	59	512	50	114	445	79
Ideal Flow (vphpl)	1900	1900	1900	1900	1900	1900	1900	1900	1900	1900	1900	1900
Storage Length (ft)	100		100	100		60	100		75	100		75
Storage Lanes	1		0	1		0	1		0	1		0
Taper Length (ft)	25			25			25			25		
Lane Util. Factor	1.00	1.00	1.00	1.00	1.00	1.00	1.00	1.00	1.00	1.00	1.00	1.00
Ped Bike Factor	0.99	0.99		1.00	0.98		1.00	1.00		1.00	1.00	
Frt		0.937			0.914			0.987				0.977
Flt Protected	0.950			0.950			0.950			0.950		
Satd. Flow (prot)	1770	1726	0	1770	1676	0	1770	1834	0	1770	1813	0
Flt Permitted	0.626			0.244			0.270			0.231		
Satd. Flow (perm)	1160	1726	0	453	1676	0	502	1834	0	429	1813	0
Right Turn on Red			Yes			Yes			Yes			No
Satd. Flow (RTOR)		80			121			13				
Link Speed (mph)		25			25			35				35
Link Distance (ft)		269			280			661				323
Travel Time (s)		7.3			7.6			12.9				6.3
Confl. Peds. (#/hr)	5		5	5		5	5		5	5		5
Peak Hour Factor	0.92	0.92	0.92	0.92	0.92	0.92	0.92	0.92	0.92	0.92	0.92	0.92
Adj. Flow (vph)	215	329	235	52	90	121	64	557	54	124	484	86
Shared Lane Traffic (%)												
Lane Group Flow (vph)	215	564	0	52	211	0	64	611	0	124	570	0
Number of Detectors	1	2		1	2		1	2		1	2	
Detector Template	Left	Thru		Left	Thru		Left	Thru		Left	Thru	
Leading Detector (ft)	20	100		20	100		20	100		20	100	
Trailing Detector (ft)	0	0		0	0		0	0		0	0	
Detector 1 Position(ft)	0	0		0	0		0	0		0	0	
Detector 1 Size(ft)	20	6		20	6		20	6		20	6	
Detector 1 Type	Cl+Ex	Cl+Ex		Cl+Ex	Cl+Ex		Cl+Ex	Cl+Ex		Cl+Ex	Cl+Ex	
Detector 1 Channel												
Detector 1 Extend (s)	0.0	0.0		0.0	0.0		0.0	0.0		0.0	0.0	
Detector 1 Queue (s)	0.0	0.0		0.0	0.0		0.0	0.0		0.0	0.0	
Detector 1 Delay (s)	0.0	0.0		0.0	0.0		0.0	0.0		0.0	0.0	
Detector 2 Position(ft)		94			94			94			94	
Detector 2 Size(ft)		6			6			6			6	
Detector 2 Type		Cl+Ex			Cl+Ex			Cl+Ex			Cl+Ex	
Detector 2 Channel												
Detector 2 Extend (s)		0.0			0.0			0.0			0.0	
Turn Type	Perm	NA		Perm	NA		Perm	NA		Perm	NA	
Protected Phases		8			4			2			5	
Permitted Phases	8			4			2			5		
Detector Phase	8	8		4	4		2	2		5	5	
Switch Phase												
Minimum Initial (s)	5.0	5.0		5.0	5.0		5.0	5.0		5.0	5.0	
Minimum Split (s)	22.0	22.0		22.0	22.0		22.0	22.0		22.0	22.0	
Total Split (s)	22.0	22.0		22.0	22.0		28.0	28.0		28.0	28.0	
Total Split (%)	44.0%	44.0%		44.0%	44.0%		56.0%	56.0%		56.0%	56.0%	

Weston Town Center
1: Weston Rd (Rt 57) & Norfield Rd

Year 2049 Plus Site ADD
Timing Plan: PM Peak



Lane Group	EBL	EBT	EBR	WBL	WBT	WBR	NBL	NBT	NBR	SBL	SBT	SBR
Maximum Green (s)	18.0	18.0		18.0	18.0		24.0	24.0		24.0	24.0	
Yellow Time (s)	3.0	3.0		3.0	3.0		3.0	3.0		3.0	3.0	
All-Red Time (s)	1.0	1.0		1.0	1.0		1.0	1.0		1.0	1.0	
Lost Time Adjust (s)	0.0	0.0		0.0	0.0		0.0	0.0		0.0	0.0	
Total Lost Time (s)	4.0	4.0		4.0	4.0		4.0	4.0		4.0	4.0	
Lead/Lag												
Lead-Lag Optimize?												
Vehicle Extension (s)	3.0	3.0		3.0	3.0		2.5	2.5		2.5	2.5	
Recall Mode	Min	Min		Min	Min		Min	Min		Min	Min	
Walk Time (s)	7.0	7.0		7.0	7.0		7.0	7.0		7.0	7.0	
Flash Dont Walk (s)	11.0	11.0		11.0	11.0		11.0	11.0		11.0	11.0	
Pedestrian Calls (#/hr)	0	0		0	0		0	0		0	0	
Act Effect Green (s)	16.4	16.4		16.4	16.4		18.3	18.3		18.3	18.3	
Actuated g/C Ratio	0.38	0.38		0.38	0.38		0.43	0.43		0.43	0.43	
v/c Ratio	0.49	0.80		0.30	0.30		0.30	0.78		0.68	0.74	
Control Delay	16.2	22.9		17.0	6.6		12.6	18.3		33.5	17.1	
Queue Delay	0.0	0.0		0.0	0.0		0.0	0.0		0.0	0.0	
Total Delay	16.2	22.9		17.0	6.6		12.6	18.3		33.5	17.1	
LOS	B	C		B	A		B	B		C	B	
Approach Delay		21.1			8.7			17.7			20.0	
Approach LOS		C			A			B			C	
Queue Length 50th (ft)	40	105		9	15		10	124		24	116	
Queue Length 95th (ft)	102	#286		36	54		32	221		#95	205	
Internal Link Dist (ft)		189			200			581			243	
Turn Bay Length (ft)	100			100			100			100		
Base Capacity (vph)	506	798		198	800		292	1073		249	1055	
Starvation Cap Reductn	0	0		0	0		0	0		0	0	
Spillback Cap Reductn	0	0		0	0		0	0		0	0	
Storage Cap Reductn	0	0		0	0		0	0		0	0	
Reduced v/c Ratio	0.42	0.71		0.26	0.26		0.22	0.57		0.50	0.54	

Intersection Summary

Area Type: Other
 Cycle Length: 50
 Actuated Cycle Length: 43
 Natural Cycle: 50
 Control Type: Actuated-Uncoordinated
 Maximum v/c Ratio: 0.80
 Intersection Signal Delay: 18.5 Intersection LOS: B
 Intersection Capacity Utilization 83.2% ICU Level of Service E
 Analysis Period (min) 15
 # 95th percentile volume exceeds capacity, queue may be longer.
 Queue shown is maximum after two cycles.

Splits and Phases: 1: Weston Rd (Rt 57) & Norfield Rd



Lanes, Volumes, Timings
MMI

Weston Town Center
1: Weston Rd (Rt 57) & Norfield Rd

Year 2049 Plus Site ADD

Timing Plan: AM Peak



Lane Group	EBL	EBT	EBR	WBL	WBT	WBR	NBL	NBT	NBR	SBL	SBT	SBR
Lane Configurations		↕		↕	↕		↕	↕		↕	↕	
Traffic Volume (vph)	90	51	43	78	310	203	113	406	40	71	541	116
Future Volume (vph)	90	51	43	78	310	203	113	406	40	71	541	116
Ideal Flow (vphpl)	1900	1900	1900	1900	1900	1900	1900	1900	1900	1900	1900	1900
Storage Length (ft)	100		100	100		60	100		75	100		0
Storage Lanes	0		0	1		0	1		0	1		0
Taper Length (ft)	25			25			25			25		
Lane Util. Factor	1.00	1.00	1.00	1.00	1.00	1.00	1.00	1.00	1.00	1.00	1.00	1.00
Ped Bike Factor		0.99		0.99	0.99		1.00	1.00		1.00	1.00	
Frt		0.968			0.941			0.987			0.974	
Flt Protected		0.976		0.950			0.950			0.950		
Satd. Flow (prot)	0	1748	0	1770	1733	0	1770	1834	0	1770	1805	0
Flt Permitted		0.392		0.657			0.174			0.370		
Satd. Flow (perm)	0	701	0	1217	1733	0	324	1834	0	687	1805	0
Right Turn on Red			Yes			Yes			Yes			No
Satd. Flow (RTOR)		29			62			12				
Link Speed (mph)		25			25			35				35
Link Distance (ft)		242			275			661				337
Travel Time (s)		6.6			7.5			12.9				6.6
Confl. Peds. (#/hr)	5		5	5		5	5		5	5		5
Peak Hour Factor	0.92	0.92	0.92	0.92	0.92	0.92	0.92	0.92	0.92	0.92	0.92	0.92
Adj. Flow (vph)	98	55	47	85	337	221	123	441	43	77	588	126
Shared Lane Traffic (%)												
Lane Group Flow (vph)	0	200	0	85	558	0	123	484	0	77	714	0
Number of Detectors	1	2		1	2		1	2		1	2	
Detector Template	Left	Thru		Left	Thru		Left	Thru		Left	Thru	
Leading Detector (ft)	20	100		20	100		20	100		20	100	
Trailing Detector (ft)	0	0		0	0		0	0		0	0	
Detector 1 Position(ft)	0	0		0	0		0	0		0	0	
Detector 1 Size(ft)	20	6		20	6		20	6		20	6	
Detector 1 Type	Cl+Ex	Cl+Ex		Cl+Ex	Cl+Ex		Cl+Ex	Cl+Ex		Cl+Ex	Cl+Ex	
Detector 1 Channel												
Detector 1 Extend (s)	0.0	0.0		0.0	0.0		0.0	0.0		0.0	0.0	
Detector 1 Queue (s)	0.0	0.0		0.0	0.0		0.0	0.0		0.0	0.0	
Detector 1 Delay (s)	0.0	0.0		0.0	0.0		0.0	0.0		0.0	0.0	
Detector 2 Position(ft)		94			94			94			94	
Detector 2 Size(ft)		6			6			6			6	
Detector 2 Type		Cl+Ex			Cl+Ex			Cl+Ex			Cl+Ex	
Detector 2 Channel												
Detector 2 Extend (s)		0.0			0.0			0.0			0.0	
Turn Type	Perm	NA		Perm	NA		Perm	NA		Perm	NA	
Protected Phases		8			4			2			5	
Permitted Phases	8			4			2			5		
Detector Phase	8	8		4	4		2	2		5	5	
Switch Phase												
Minimum Initial (s)	5.0	5.0		5.0	5.0		5.0	5.0		5.0	5.0	
Minimum Split (s)	22.0	22.0		22.0	22.0		30.7	30.7		28.0	28.0	
Total Split (s)	26.0	26.0		26.0	26.0		34.0	34.0		34.0	34.0	
Total Split (%)	43.3%	43.3%		43.3%	43.3%		56.7%	56.7%		56.7%	56.7%	

Weston Town Center
 1: Weston Rd (Rt 57) & Norfield Rd

Year 2049 Plus Site ADD
 Timing Plan: AM Peak



Lane Group	EBL	EBT	EBR	WBL	WBT	WBR	NBL	NBT	NBR	SBL	SBT	SBR
Maximum Green (s)	22.0	22.0		22.0	22.0		30.0	30.0		30.0	30.0	
Yellow Time (s)	3.0	3.0		3.0	3.0		3.0	3.0		3.0	3.0	
All-Red Time (s)	1.0	1.0		1.0	1.0		1.0	1.0		1.0	1.0	
Lost Time Adjust (s)		0.0		0.0	0.0		0.0	0.0		0.0	0.0	
Total Lost Time (s)		4.0		4.0	4.0		4.0	4.0		4.0	4.0	
Lead/Lag												
Lead-Lag Optimize?												
Vehicle Extension (s)	3.0	3.0		3.0	3.0		2.5	2.5		2.5	2.5	
Recall Mode	Min	Min		Min	Min		Min	Min		Min	Min	
Walk Time (s)	7.0	7.0		7.0	7.0		7.0	7.0		7.0	7.0	
Flash Dont Walk (s)	11.0	11.0		11.0	11.0		11.0	11.0		11.0	11.0	
Pedestrian Calls (#/hr)	0	0		0	0		0	0		0	0	
Act Effect Green (s)		19.2		19.2	19.2		24.9	24.9		24.9	24.9	
Actuated g/C Ratio		0.37		0.37	0.37		0.47	0.47		0.47	0.47	
v/c Ratio		0.73		0.19	0.83		0.80	0.55		0.24	0.84	
Control Delay		32.8		14.1	27.6		54.0	12.7		10.8	23.1	
Queue Delay		0.0		0.0	0.0		0.0	0.0		0.0	0.0	
Total Delay		32.8		14.1	27.6		54.0	12.7		10.8	23.1	
LOS		C		B	C		D	B		B	C	
Approach Delay		32.8			25.8			21.0			21.9	
Approach LOS		C			C			C			C	
Queue Length 50th (ft)		50		20	155		33	106		14	197	
Queue Length 95th (ft)		#153		48	#326		#122	179		38	#388	
Internal Link Dist (ft)		162			195			581			257	
Turn Bay Length (ft)				100			100			100		
Base Capacity (vph)		324		535	796		194	1105		412	1082	
Starvation Cap Reductn		0		0	0		0	0		0	0	
Spillback Cap Reductn		0		0	0		0	0		0	0	
Storage Cap Reductn		0		0	0		0	0		0	0	
Reduced v/c Ratio		0.62		0.16	0.70		0.63	0.44		0.19	0.66	

Intersection Summary

Area Type: Other
 Cycle Length: 60
 Actuated Cycle Length: 52.5
 Natural Cycle: 60
 Control Type: Actuated-Uncoordinated
 Maximum v/c Ratio: 0.84
 Intersection Signal Delay: 23.8
 Intersection LOS: C
 Intersection Capacity Utilization 95.2%
 ICU Level of Service F
 Analysis Period (min) 15
 # 95th percentile volume exceeds capacity, queue may be longer.
 Queue shown is maximum after two cycles.

Splits and Phases: 1: Weston Rd (Rt 57) & Norfield Rd

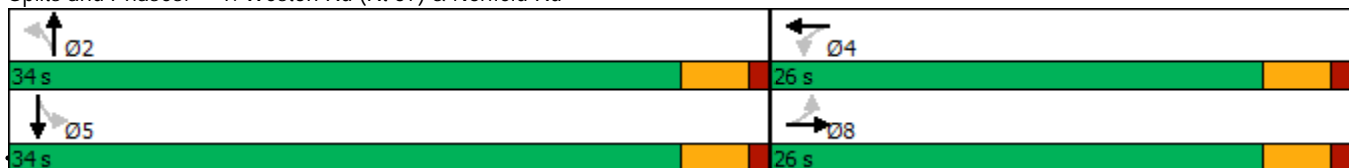

Weston Town Center
1: Weston Rd (Rt 57) & Norfield Rd

Year 2049 Plus Site ADD
Timing Plan: PM Peak



Lane Group	EBL	EBT	EBR	WBL	WBT	WBR	NBL	NBT	NBR	SBL	SBT	SBR
Lane Configurations		↕		↖	↗		↖	↗		↖	↗	
Traffic Volume (vph)	198	303	216	48	83	111	59	512	50	114	445	79
Future Volume (vph)	198	303	216	48	83	111	59	512	50	114	445	79
Ideal Flow (vphpl)	1900	1900	1900	1900	1900	1900	1900	1900	1900	1900	1900	1900
Storage Length (ft)	100		100	100		60	100		75	100		75
Storage Lanes	0		0	1		0	1		0	1		0
Taper Length (ft)	25			25			25			25		
Lane Util. Factor	1.00	1.00	1.00	1.00	1.00	1.00	1.00	1.00	1.00	1.00	1.00	1.00
Ped Bike Factor		0.99		1.00	0.98		1.00	1.00		1.00	1.00	
Frt		0.959		0.914			0.987				0.977	
Flt Protected		0.986		0.950			0.950			0.950		
Satd. Flow (prot)	0	1747	0	1770	1676	0	1770	1834	0	1770	1813	0
Flt Permitted		0.837		0.353			0.227			0.227		
Satd. Flow (perm)	0	1481	0	656	1676	0	422	1834	0	422	1813	0
Right Turn on Red			Yes			Yes			Yes			No
Satd. Flow (RTOR)		60			121			11				
Link Speed (mph)		25			25			35				35
Link Distance (ft)		269			280			661				323
Travel Time (s)		7.3			7.6			12.9				6.3
Confl. Peds. (#/hr)	5		5	5		5	5		5	5		5
Peak Hour Factor	0.92	0.92	0.92	0.92	0.92	0.92	0.92	0.92	0.92	0.92	0.92	0.92
Adj. Flow (vph)	215	329	235	52	90	121	64	557	54	124	484	86
Shared Lane Traffic (%)												
Lane Group Flow (vph)	0	779	0	52	211	0	64	611	0	124	570	0
Number of Detectors	1	2		1	2		1	2		1	2	
Detector Template	Left	Thru		Left	Thru		Left	Thru		Left	Thru	
Leading Detector (ft)	20	100		20	100		20	100		20	100	
Trailing Detector (ft)	0	0		0	0		0	0		0	0	
Detector 1 Position(ft)	0	0		0	0		0	0		0	0	
Detector 1 Size(ft)	20	6		20	6		20	6		20	6	
Detector 1 Type	Cl+Ex	Cl+Ex		Cl+Ex	Cl+Ex		Cl+Ex	Cl+Ex		Cl+Ex	Cl+Ex	
Detector 1 Channel												
Detector 1 Extend (s)	0.0	0.0		0.0	0.0		0.0	0.0		0.0	0.0	
Detector 1 Queue (s)	0.0	0.0		0.0	0.0		0.0	0.0		0.0	0.0	
Detector 1 Delay (s)	0.0	0.0		0.0	0.0		0.0	0.0		0.0	0.0	
Detector 2 Position(ft)		94			94			94			94	
Detector 2 Size(ft)		6			6			6			6	
Detector 2 Type		Cl+Ex			Cl+Ex			Cl+Ex			Cl+Ex	
Detector 2 Channel												
Detector 2 Extend (s)		0.0			0.0			0.0			0.0	
Turn Type	Perm	NA		Perm	NA		Perm	NA		Perm	NA	
Protected Phases		8			4			2			5	
Permitted Phases	8			4			2			5		
Detector Phase	8	8		4	4		2	2		5	5	
Switch Phase												
Minimum Initial (s)	5.0	5.0		5.0	5.0		5.0	5.0		5.0	5.0	
Minimum Split (s)	22.0	22.0		22.0	22.0		22.0	22.0		22.0	22.0	
Total Split (s)	28.0	28.0		28.0	28.0		22.0	22.0		22.0	22.0	
Total Split (%)	56.0%	56.0%		56.0%	56.0%		44.0%	44.0%		44.0%	44.0%	

Weston Town Center
1: Weston Rd (Rt 57) & Norfield Rd

Year 2049 Plus Site ADD
Timing Plan: PM Peak



Lane Group	EBL	EBT	EBR	WBL	WBT	WBR	NBL	NBT	NBR	SBL	SBT	SBR
Maximum Green (s)	24.0	24.0		24.0	24.0		18.0	18.0		18.0	18.0	
Yellow Time (s)	3.0	3.0		3.0	3.0		3.0	3.0		3.0	3.0	
All-Red Time (s)	1.0	1.0		1.0	1.0		1.0	1.0		1.0	1.0	
Lost Time Adjust (s)		0.0		0.0	0.0		0.0	0.0		0.0	0.0	
Total Lost Time (s)		4.0		4.0	4.0		4.0	4.0		4.0	4.0	
Lead/Lag												
Lead-Lag Optimize?												
Vehicle Extension (s)	3.0	3.0		3.0	3.0		2.5	2.5		2.5	2.5	
Recall Mode	Min	Min		Min	Min		Min	Min		Min	Min	
Walk Time (s)	7.0	7.0		7.0	7.0		7.0	7.0		7.0	7.0	
Flash Dont Walk (s)	11.0	11.0		11.0	11.0		11.0	11.0		11.0	11.0	
Pedestrian Calls (#/hr)	0	0		0	0		0	0		0	0	
Act Effect Green (s)		24.0		24.0	24.0		17.6	17.6		17.6	17.6	
Actuated g/C Ratio		0.48		0.48	0.48		0.35	0.35		0.35	0.35	
v/c Ratio		1.04		0.16	0.24		0.43	0.93		0.83	0.89	
Control Delay		61.5		9.0	4.4		22.9	40.2		63.0	34.7	
Queue Delay		0.0		0.0	0.0		0.0	0.0		0.0	0.0	
Total Delay		61.5		9.0	4.4		22.9	40.2		63.0	34.7	
LOS		E		A	A		C	D		E	C	
Approach Delay		61.5			5.3			38.5			39.8	
Approach LOS		E			A			D			D	
Queue Length 50th (ft)		-251		8	13		14	162		32	150	
Queue Length 95th (ft)		#433		24	41		#49	#340		#112	#311	
Internal Link Dist (ft)		189			200			581			243	
Turn Bay Length (ft)				100			100			100		
Base Capacity (vph)		747		317	873		152	672		152	657	
Starvation Cap Reductn		0		0	0		0	0		0	0	
Spillback Cap Reductn		0		0	0		0	0		0	0	
Storage Cap Reductn		0		0	0		0	0		0	0	
Reduced v/c Ratio		1.04		0.16	0.24		0.42	0.91		0.82	0.87	

Intersection Summary

Area Type: Other
 Cycle Length: 50
 Actuated Cycle Length: 49.6
 Natural Cycle: 55
 Control Type: Actuated-Uncoordinated
 Maximum v/c Ratio: 1.04
 Intersection Signal Delay: 42.7
 Intersection LOS: D
 Intersection Capacity Utilization 101.9%
 ICU Level of Service G
 Analysis Period (min) 15
 ~ Volume exceeds capacity, queue is theoretically infinite.
 Queue shown is maximum after two cycles.
 # 95th percentile volume exceeds capacity, queue may be longer.
 Queue shown is maximum after two cycles.

Splits and Phases: 1: Weston Rd (Rt 57) & Norfield Rd

