

SURVEY NOTES:
 1. THIS SURVEY (OR MAP) HAS BEEN PREPARED PURSUANT TO THE REGULATIONS OF CONNECTICUT STATE AGENCIES SECTIONS 20-300b-1 THRU 20-300b-20 AND THE "STANDARDS FOR SURVEYS AND MAPS IN THE STATE OF CONNECTICUT" AS ADOPTED BY THE CONNECTICUT ASSOCIATION OF LAND SURVEYORS, INC. ON SEPTEMBER 26, 1996. IT IS AN IMPROVEMENT LOCATION SURVEY BASED ON A DEPENDENT RESURVEY CONFORMING TO HORIZONTAL ACCURACY CLASS A-2 AND VERTICAL ACCURACY CLASS V-2 AND INTENDED TO BE USED FOR REGULATORY APPROVAL.
 2. REFERENCE IS MADE TO THE FOLLOWING MAP:
 A) "PLOT PLAN PREPARED FOR JAMES HARMON, 34 KETTLE CREEK ROAD, WESTON, CONN." SCALE 1"=40'. DATED JUNE 5, 2022. PREPARED BY LEONARD SURVEYORS LLC.

- STANDARD NOTES**
- All construction methods, materials and installation of the system to be in accordance with all applicable local and state regulations.
 - Topographic and property data shown are only approximate.
 - Topographic data based on STATE OF CT GIS DATA, property lines based on REFERENCED MAPS.
 - The test results and soil types shown apply only to the test holes shown and may vary throughout the site. Soil type and grade should be verified by the owner over the entire leaching area prior to construction.
 - Select fill, if required, to be placed in maximum of 12" lifts and to be compacted to a minimum of 90% compaction. Material to have a maximum of 5% passing the #200 sieve. Prior to the delivery of select fill to the site, the contractor at his expense, shall furnish a certified gradation analysis to the local Health Department and to the Design Engineer. Final approval of septic fill will be conditional on the completion of a percolation test on the in-place material. This test is to be witnessed by the Design Engineer and/or local Health Department official. The maximum allowable percolation rate will be 1" in 10 minutes, unless otherwise noted.
 - Unless otherwise directed hereon, the site requiring placement of select fill shall be prepared by removing all topsoil in the system area and 5 ft on all sides. No heavy equipment shall be used in the prepared area. Fill shall be placed on the perimeter of the trench area and spread with a small crawler, tractor or other approved machinery. Upon placement of the first lift of select fill, material shall be thoroughly harrowed into the existing subsoil layer.
 - Call "Call Before You Dig" 1-800-922-4455 to locate underground utilities on property and show service lines to building from public utilities shown on plan.
 - Contractor shall contact the certifying engineer and Health department at least 24 hours prior to starting construction, or the system installation will not be certified.
 - Oil tank is to be installed inside proposed building.
 - The licensed installer shall cover the septic system with clean soil as prescribed by the latest revision of Technical Standards. Clean soil is native soil, free of contaminants such as boulders, building debris, stumps, etc.
 - Septic system to be staked by Engineer/Surveyor and benchmark set prior to starting construction.
 - A sieve analysis of the septic fill is to be provided to the health district and design engineer verifying compliance to Health Code requirements prior to placement on site.
 - Prior to backfilling septic system Engineer/Surveyor to asbuilt completed septic system and provide plan to health department.

SOIL TEST DATA SOIL TESTING PERFORMED ON 06-30-23

TH-3-1	TH-3-3
0-13" Topsoil	0-10" Topsoil
13-24" Orange Brown Silty Sand	10-13" Orange Brown Silty Sand
24-75" Gray Brown Silty Sand	13-44" Orange Brown Silty Sand
Groundwater Seep @ 32", Mottles @ 24", No Ledger, Roots to 30"	44-60" Gray Brown Silty Sand
Rest Layer 24"	Groundwater Seep @ 16", Mottles @ 15", No Ledger, Roots to 10"
	Rest Layer 18"
TH-3-2	TH-3-4
0-18" Topsoil	0-10" Topsoil
18-30" Orange Brown Silty Sand	10-12" Orange Brown Silty Sand
30-64" Gray Brown Silty Sand	12-30" Gray Brown Silty Sand
Groundwater Seep @ 38", Mottles @ 20", Ledger @ 65", Roots to 12"	Groundwater Seep @ 18", Mottles @ 11", No Ledger, Roots to 10"
Rest Layer 20"	Rest Layer 18"

PERCOLATION TEST PERFORMED 5-7-24
 DEPTH 20"
 PRESOAK 2 HOURS

TIME	MW-2	READING
0 MIN.	5 1/2"	
10 MIN.	7"	
20 MIN.	8 1/2"	
30 MIN.	8 1/2"	
40 MIN.	9"	
50 MIN.	9 1/2"	
60 MIN.	10"	
RATE 1" IN 20 MIN.		

DESIGN INFORMATION
 1012.5 SF EFFECTIVE LEACHING AREA REQUIRED FOR 6 BEDROOM HOUSE
 1400 SF EFFECTIVE LEACHING AREA PROVIDED FOR 6 BEDROOM HOUSE
 70 lined feet of MANTIS DOUBLE WIDE 100 UNITS required for proposed 6 bedroom house.
 MLSS CALCULATIONS: Depth= 36" Slope = 9.5% HF= 24 FF= 2.25 PF= 1.25
 MLSS = (HF) X (FF) X (PF) = 67.5
 * CALCULATED PER CATEGORY 2, RS DEPTH CALCULATION, "CONNECTICUT PUBLIC HEALTH CODE, ON-SITE SEWAGE DISPOSAL REGULATIONS AND TECHNICAL STANDARDS FOR SUBSURFACE SEWAGE DISPOSAL SYSTEMS 2024" PAGE 61

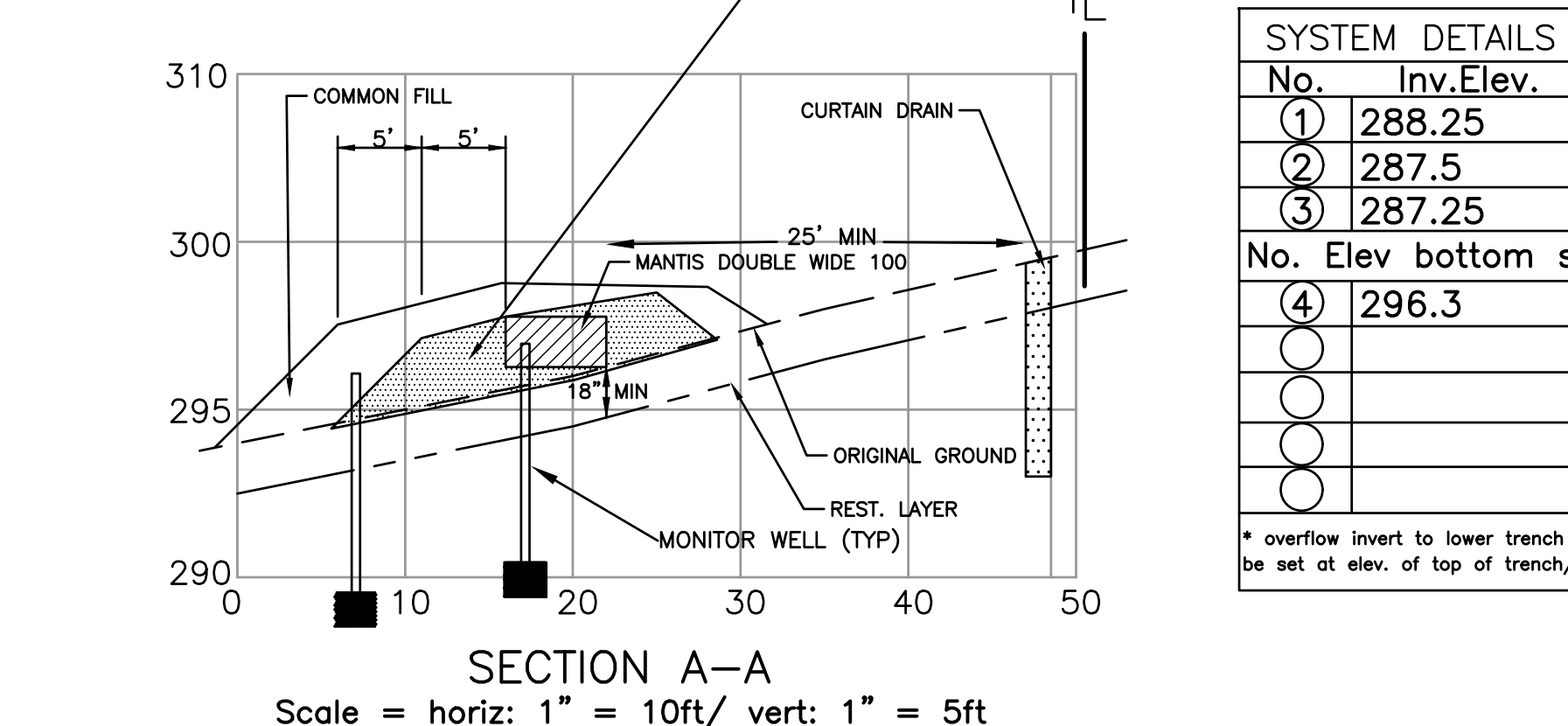
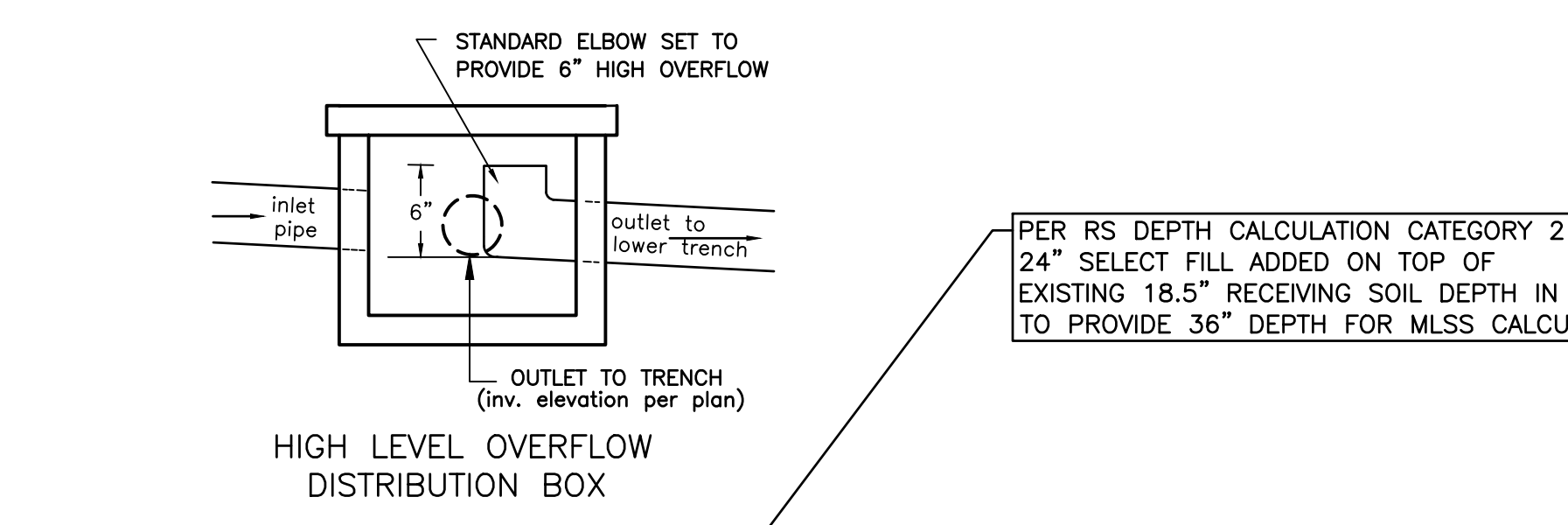

I HEREBY CERTIFY THAT THE PERCOLATION TEST(S) SHOWN HEREON WERE CONDUCTED IN CONFORMANCE WITH ALL CURRENT STATE REGULATIONS UNLESS OTHERWISE NOTED HEREON.

JASON EDWARDS, No. 70308

LARRY EDWARDS, No. 10937

