



Incorporated 1787

Conservation Commission

RECEIVED

AUG 07 2023

TOWN OF WESTON
CONSERVATION COMMISSION

INLAND WETLANDS AND WATERCOURSES APPLICATION

This Application is for a five-year permit to conduct a regulated activity or activities pursuant to the Inland Wetlands and Watercourses Regulations of the Town of Weston ("The Regulations")

PROPERTY ADDRESS: 21 Lords Highway, Weston, CT

Assessor's Map # 20 Block # 1 Lot # 7

PROJECT DESCRIPTION (general purpose) Addition to existing home

Total Acres 2.958 Total Acres of Wetlands and Watercourses 701 - 1/2 acres

Acreage of Wetlands and Watercourses Altered 0 Upland Area Altered 0

Acres Linear Feet of Stream Alteration 0 Total Acres Proposed Open Space 0

OWNER(S) OF RECORD: (Please list all owners, attach extra sheet if necessary)

Name: Roger & Lisa Passavant Phone: 860-706-7717

Address: 21 Lords Highway - Weston, CT

Email: Lisa@RivendellFarm.net

APPLICANT/AUTHORIZED AGENT:

Name: Jim Jamieson Phone: 203 515-9543

Address: 110 Weston Road, Weston, CT

Email: JIM@JAMIESONARCHITECTS.COM

CONSULTANTS: (Please provide, if applicable)

Engineer: Grumman Engineering Phone: 203-853-2833

Address: 20 Knight Street - Norwalk Email: _____

Soil Scientist: Otto Theal Phone: 203-845-0278

Address: 2 Lloyd Road, Norwalk Email: _____

Legal Counsel: Joseph Gerardi Phone: 203-329-2954

Address: 1074 Hope St. Stamford Email: _____

Surveyor: Brantigan Surveyors Phone: 203-270-7810

Address: 90 S. Main St. Newtown Email: surveying@Brantiganland.com

PROPERTY INFORMATION

Property Address: 21 Lords Highway, Weston, CT

Existing Conditions (Describe existing property and structures): 1940 Cape, 1598 sq.ft. detached 2 story barn - 590 sq.ft. 2.95 acres.

Provide a detailed description and purpose of proposed activity (attach sheet with additional information if needed): Construction of addition off rear of house
Approximate addition size 1,102 sq.ft.

Is this property within a subdivision (circle): Yes or (No)
Square feet of proposed impervious surfaces (roads, buildings, parking, etc.): 1,102

Subject property to be affected by proposed activity contains:

- | | |
|--|---|
| <input checked="" type="checkbox"/> wetlands soils | <input type="checkbox"/> bog |
| <input type="checkbox"/> swamp | <input type="checkbox"/> lake or pond |
| <input type="checkbox"/> floodplain | <input checked="" type="checkbox"/> stream or river |
| <input type="checkbox"/> marsh | <input type="checkbox"/> other _____ |

The proposed activity will involve the following within wetlands, watercourse, and/or review area:

- | | | |
|--|--|--|
| <input checked="" type="checkbox"/> Alteration | <input checked="" type="checkbox"/> Construction | <input type="checkbox"/> Pollution |
| <input type="checkbox"/> Discharge to | <input type="checkbox"/> Discharge from | <input type="checkbox"/> Bridge or Culvert |
| <input type="checkbox"/> Removal of | <input type="checkbox"/> Deposition of | <input type="checkbox"/> Other _____ |
| Materials | Materials | |

Amount, type, and location of materials to be removed, deposited, or stockpiled:
please see attached *

Description, work sequence, and duration of activities:
Construction of addition, proposed construction time of 6 months, beginning immediately upon approval of application

Describe alternatives considered and why the proposal described herein was chosen:
It is the best location on the property with the least impact on topography & existing septic.

Does the proposed activity involve the installation and/or repair of an existing septic system(s) (circle): Yes or (No)

The Westport/Weston Health District Approval: _____

ADJOINING MUNICIPALITIES AND NOTICE:

If any of the situations below apply, the applicant is required to give written notice of his/her application to the Inland Wetlands Agency of the adjoining municipality, on the same day that he/she submits this application. Notification must be sent by Certified Mail with Return Receipt Requested.

The property is located within 500 feet of any town boundary line;

A significant portion of the traffic to the completed project will use streets within the adjoining municipality to enter or exit the site;

A portion of the water drainage from the project site will flow through and significantly impact the sewage system or drainage systems within the adjoining municipality; or

Water runoff from the improved site will impact streets or other municipal or private property within the adjoining municipality

AQUARION WATER COMPANY

Pursuant to Section 8.4 of the Weston regulations, the Aquarion Water Company must be notified of any regulated activity proposed within its watersheds. Maps showing approximate watershed boundaries are available at the office of the Commission. If the project site lies within these boundaries, send notice, site plan, and grading and erosion control plan via certified mail, return receipt requested, within seven (7) days of submitting application to the Commission, to:

George S. Logan, Director – Environmental Management
Aquarion Water Company
714 Black Rock Turnpike
Easton, CT 06612

The Commissioner of the Connecticut Department of Public Health must also be notified in the same manner in a format prescribed by that commissioner.

The undersigned, as owner(s) of the property, hereby consents to necessary and proper inspections of the above mentioned property by Commissioners and agents of the Conservation Commission, Town of Weston, at reasonable times, both before and after a final decision has been issued by the Commission.

The undersigned hereby acknowledges to have read the "Application Requirements and Procedures" in completing this application.

The undersigned hereby certifies that the information provided in this application, including its supporting documentation is true and he/she is aware of the penalties provided in Section 22a-376 of the Connecticut General Statutes for knowingly providing false or misleading information.

Joe Pasquet / Steve Pasquet 8/4/2023
Signature of Owner(s) of Record Date

Signature of Authorized Agent Date

FOR OFFICE USE ONLY

Administrative Approval _____
Initials Date

DRAINAGE ANALYSIS

PREPARED FOR

PROPOSED IMPROVEMENTS

LOCATED AT

21 LORDS HIGHWAY

WESTON, CONNECTICUT

GE #23-5642

AUGUST 2, 2023



GRUMMAN ENGINEERING, LLC
CONSULTING CIVIL ENGINEERS
20 KNIGHT STREET
NORWALK, CONNECTICUT 06851
(203) 853-3833
FAX 286-5057

NARRATIVE:

The subject of this report is a 2.958+/- acre parcel located at 21 Lords Highway, Weston. The purpose of the report is to determine the change in stormwater runoff resulting from the proposed building addition and to provide mitigation in accordance with Town of Weston standards.

EXISTING CONDITIONS:

This site contains an existing single-family dwelling constructed in 1940. The property which is situated on the south side of Lords Highway, is accessed off School Road with a gravel driveway. The existing dwelling is located near the center of the site. A brook and wetland bisect the property in the eastern portion with a wetland area in the northwest corner. The existing dwelling is served by a private well and on-site sewage disposal system. Existing topography at this location slopes from a high point near the southeast corner to the north and west with grades of 4-50%.

Existing upland soils at this location are identified in the NRCS Web Soil Survey as being Paxton and Montauk, fine sandy loams, HSG 'C' and Udorthants-Urban land complex, HSG 'B'.

PROPOSED CONDITIONS:

The proposal for this site is to construct an addition onto the northwest side of the existing dwelling, in an existing lawn area. The area surrounding the proposed addition will be regraded with the aid of a retaining wall to create a walk-out from the basement level on the western side.

The site was analyzed to determine the existing and proposed peak runoff rates and on-site retention of the increased runoff was proposed using Cultec R-150XLHD chambers.

The following computations utilize the Hydrocad computer software and a 50-year design storm. Rainfall data was taken from the NOAA Atlas 14 for this location.

COMPUTATIONS:

Existing Conditions:

Lawn -	1,051 s.f.	CN-74
Bilco -	23 s.f.	CN-98
Total -	1,074 s.f.	

Proposed Conditions:

Prop. Addition -	1,074 s.f.	CN-98
Total -	1,074 s.f.	

Water Quality Volume (WQV) – First 1” of runoff from new impervious surfaces to be stored and treated.

$$WQV = \frac{(1") (R) (A)}{12}$$

$$R = 0.05 + 0.009I$$

I = % Impervious
A = Area

$$WQV = \frac{(1") (0.95) (1,051 \text{ s.f.})}{12}$$

$$WQV = 83.2 \text{ c.f.}$$

SUMMARY:

Existing Conditions Runoff -	0.11 c.f.s. (399 c.f.)
Proposed Conditions Runoff -	0.18 c.f.s. (648 c.f.)
Proposed Conditions Runoff – w/ Retention	0.09 c.f.s. (324 c.f.)

CONCLUSIONS:

The installation of (2) Cultec R-150XLHD chamber, (20.5 l.f.) will be adequate to provide storage of the increased runoff resulting from the proposed improvements. Runoff from 50% of the proposed building addition will be intercepted and routed into the retention system.

This retention system will also provide the required water quality volume.

There will be no adverse impact on wetland areas or adjacent properties as a result of the proposed improvements.



Existing Conditions



Proposed Conditions



50% Roof Runoff



On-Site Retention



Total Runoff



Time span=0.00-24.00 hrs, dt=0.05 hrs, 481 points
Runoff by SCS TR-20 method, UH=SCS, Weighted-CN
Reach routing by Stor-Ind+Trans method - Pond routing by Stor-Ind method

Subcatchment 1S: Existing Conditions

Runoff Area=1,074 sf 0.00% Impervious Runoff Depth>4.46"
Tc=10.0 min CN=74 Runoff=0.11 cfs 399 cf

Subcatchment 2S: Proposed Conditions

Runoff Area=537 sf 100.00% Impervious Runoff Depth>7.24"
Tc=5.0 min CN=98 Runoff=0.09 cfs 324 cf

Subcatchment 3S: 50% Roof Runoff

Runoff Area=537 sf 100.00% Impervious Runoff Depth>7.24"
Tc=5.0 min CN=98 Runoff=0.09 cfs 324 cf

Pond 4P: On-Site Retention

Peak Elev=301.32' Storage=113 cf Inflow=0.09 cfs 324 cf
Discarded=0.01 cfs 324 cf Primary=0.00 cfs 0 cf Outflow=0.01 cfs 324 cf

Link 5L: Total Runoff

Inflow=0.09 cfs 324 cf
Primary=0.09 cfs 324 cf

Total Runoff Area = 2,148 sf Runoff Volume = 1,047 cf Average Runoff Depth = 5.85"
50.00% Pervious = 1,074 sf 50.00% Impervious = 1,074 sf

Summary for Subcatchment 1S: Existing Conditions

Runoff = 0.11 cfs @ 12.14 hrs, Volume= 399 cf, Depth> 4.46"

Runoff by SCS TR-20 method, UH=SCS, Weighted-CN, Time Span= 0.00-24.00 hrs, dt= 0.05 hrs
 Type III 24-hr 50-Year Rainfall=7.48"

Area (sf)	CN	Description
1,074	74	>75% Grass cover, Good, HSG C
1,074		100.00% Pervious Area

Tc (min)	Length (feet)	Slope (ft/ft)	Velocity (ft/sec)	Capacity (cfs)	Description
10.0					Direct Entry,

Subcatchment 1S: Existing Conditions

Hydrograph

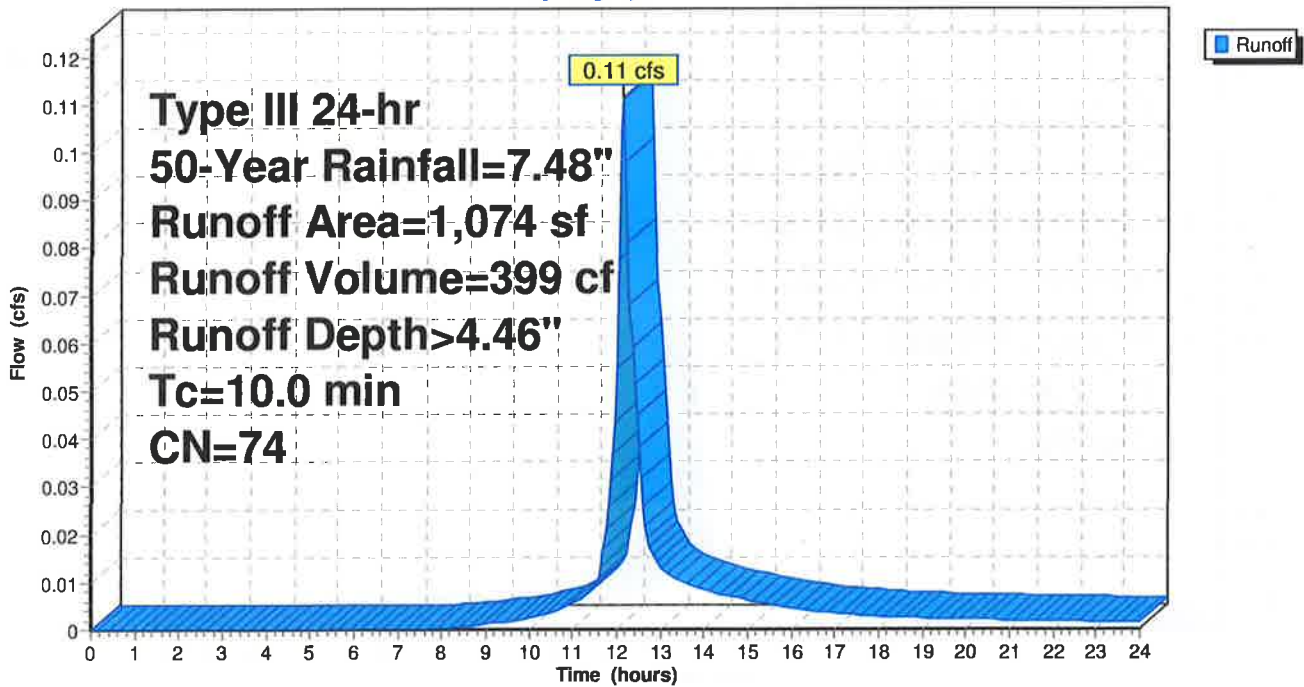

Summary for Subcatchment 2S: Proposed Conditions

Runoff = 0.09 cfs @ 12.07 hrs, Volume= 324 cf, Depth> 7.24"

Runoff by SCS TR-20 method, UH=SCS, Weighted-CN, Time Span= 0.00-24.00 hrs, dt= 0.05 hrs
 Type III 24-hr 50-Year Rainfall=7.48"

Area (sf)	CN	Description
* 537	98	Building Addituiou
537		100.00% Impervious Area

Tc (min)	Length (feet)	Slope (ft/ft)	Velocity (ft/sec)	Capacity (cfs)	Description
5.0					Direct Entry,

Subcatchment 2S: Proposed Conditions

Hydrograph

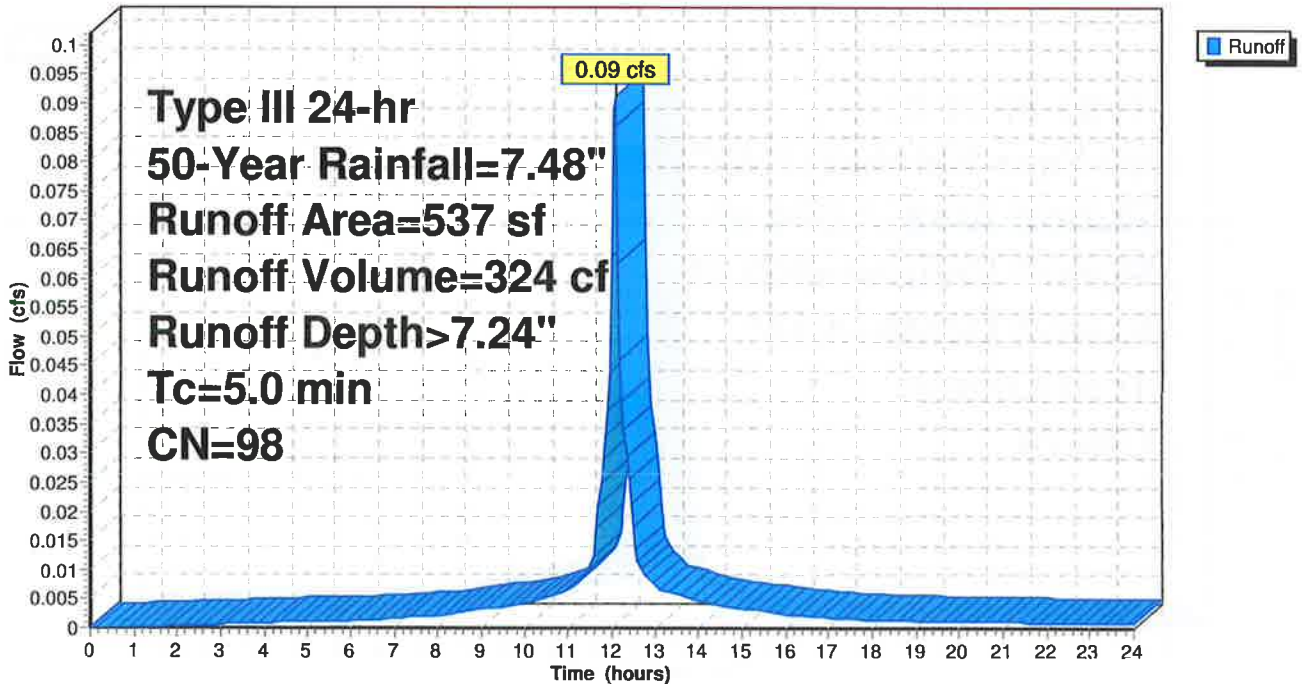

Summary for Subcatchment 3S: 50% Roof Runoff

Runoff = 0.09 cfs @ 12.07 hrs, Volume= 324 cf, Depth> 7.24"

Runoff by SCS TR-20 method, UH=SCS, Weighted-CN, Time Span= 0.00-24.00 hrs, dt= 0.05 hrs
 Type III 24-hr 50-Year Rainfall=7.48"

Area (sf)	CN	Description
* 537	98	50% Building Addition
537		100.00% Impervious Area

Tc (min)	Length (feet)	Slope (ft/ft)	Velocity (ft/sec)	Capacity (cfs)	Description
5.0					Direct Entry,

Subcatchment 3S: 50% Roof Runoff

Hydrograph

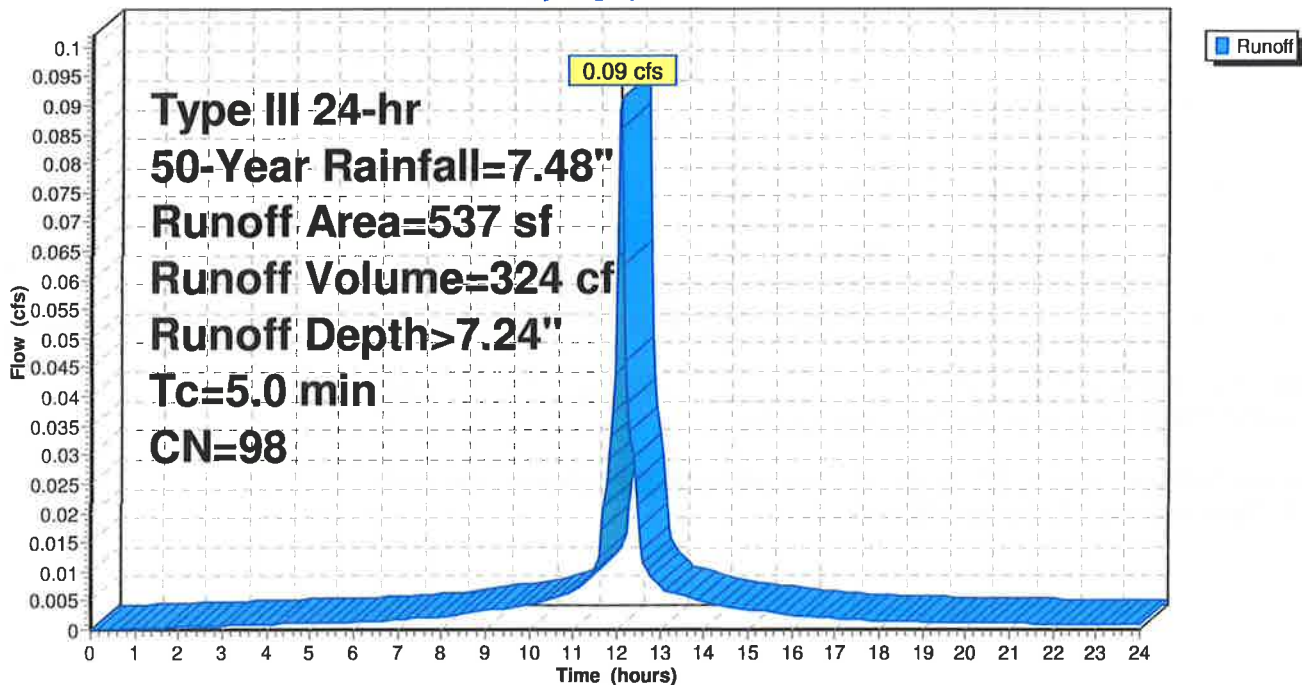

Summary for Pond 4P: On-Site Retention

Inflow Area = 537 sf, 100.00% Impervious, Inflow Depth > 7.24" for 50-Year event
 Inflow = 0.09 cfs @ 12.07 hrs, Volume= 324 cf
 Outflow = 0.01 cfs @ 11.25 hrs, Volume= 324 cf, Atten= 92%, Lag= 0.0 min
 Discarded = 0.01 cfs @ 11.25 hrs, Volume= 324 cf
 Primary = 0.00 cfs @ 0.00 hrs, Volume= 0 cf

Routing by Stor-Ind method, Time Span= 0.00-24.00 hrs, dt= 0.05 hrs
 Peak Elev= 301.32' @ 12.97 hrs Surf.Area= 110 sf Storage= 113 cf

Plug-Flow detention time= 102.2 min calculated for 323 cf (100% of inflow)
 Center-of-Mass det. time= 101.7 min (842.6 - 740.8)

Volume	Invert	Avail.Storage	Storage Description
#1A	299.50'	90 cf	4.75'W x 23.25'L x 2.54'H Field A 281 cf Overall - 56 cf Embedded = 224 cf x 40.0% Voids
#2A	300.00'	56 cf	Cultec R-150XLHD x 2 Inside #1 Effective Size= 29.8"W x 18.0"H => 2.65 sf x 10.25'L = 27.2 cf Overall Size= 33.0"W x 18.5"H x 11.00'L with 0.75' Overlap Row Length Adjustment= +0.75' x 2.65 sf x 1 rows
		146 cf	Total Available Storage

Storage Group A created with Chamber Wizard

Device	Routing	Invert	Outlet Devices
#1	Discarded	299.50'	3.000 in/hr Exfiltration over Horizontal area
#2	Primary	302.54'	6.0" Horiz. Orifice/Grate C= 0.600 Limited to weir flow at low heads

Discarded OutFlow Max=0.01 cfs @ 11.25 hrs HW=299.53' (Free Discharge)
 ↑1=Exfiltration (Exfiltration Controls 0.01 cfs)

Primary OutFlow Max=0.00 cfs @ 0.00 hrs HW=299.50' (Free Discharge)
 ↑2=Orifice/Grate (Controls 0.00 cfs)

Pond 4P: On-Site Retention

Hydrograph

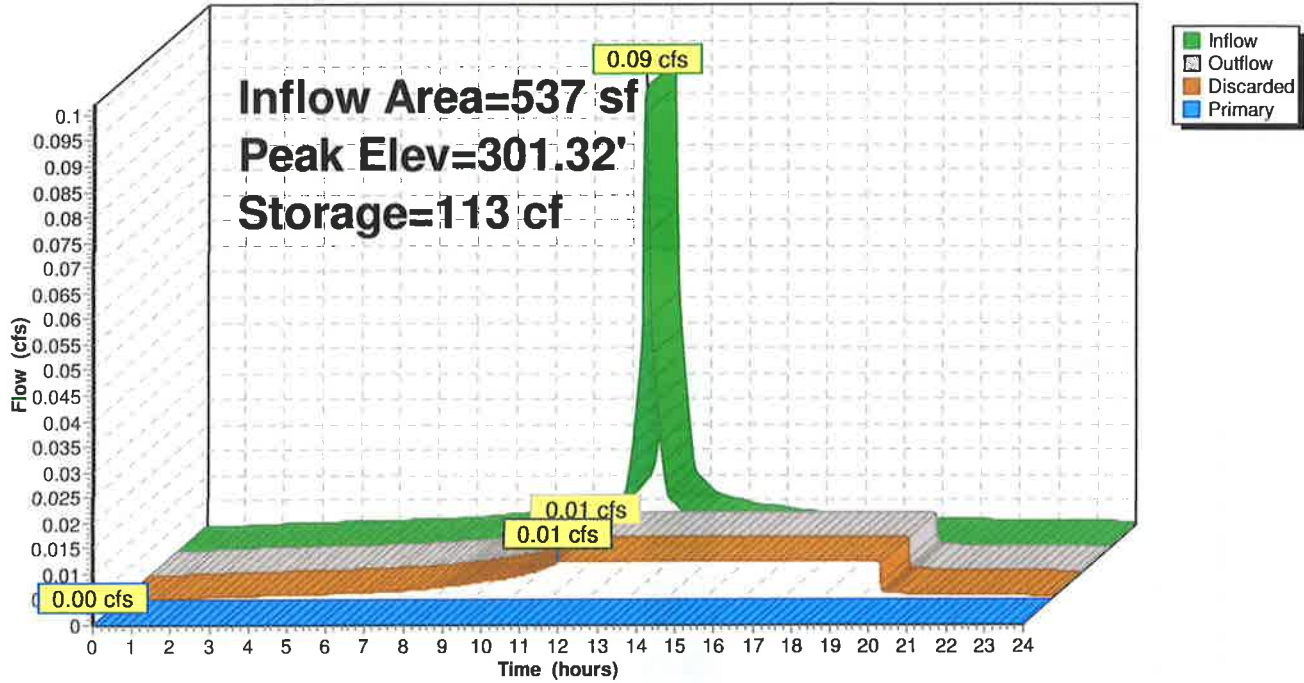

Summary for Link 5L: Total Runoff

Inflow Area = 1,074 sf, 100.00% Impervious, Inflow Depth > 3.62" for 50-Year event
Inflow = 0.09 cfs @ 12.07 hrs, Volume= 324 cf
Primary = 0.09 cfs @ 12.07 hrs, Volume= 324 cf, Atten= 0%, Lag= 0.0 min

Primary outflow = Inflow, Time Span= 0.00-24.00 hrs, dt= 0.05 hrs

Link 5L: Total Runoff

Hydrograph

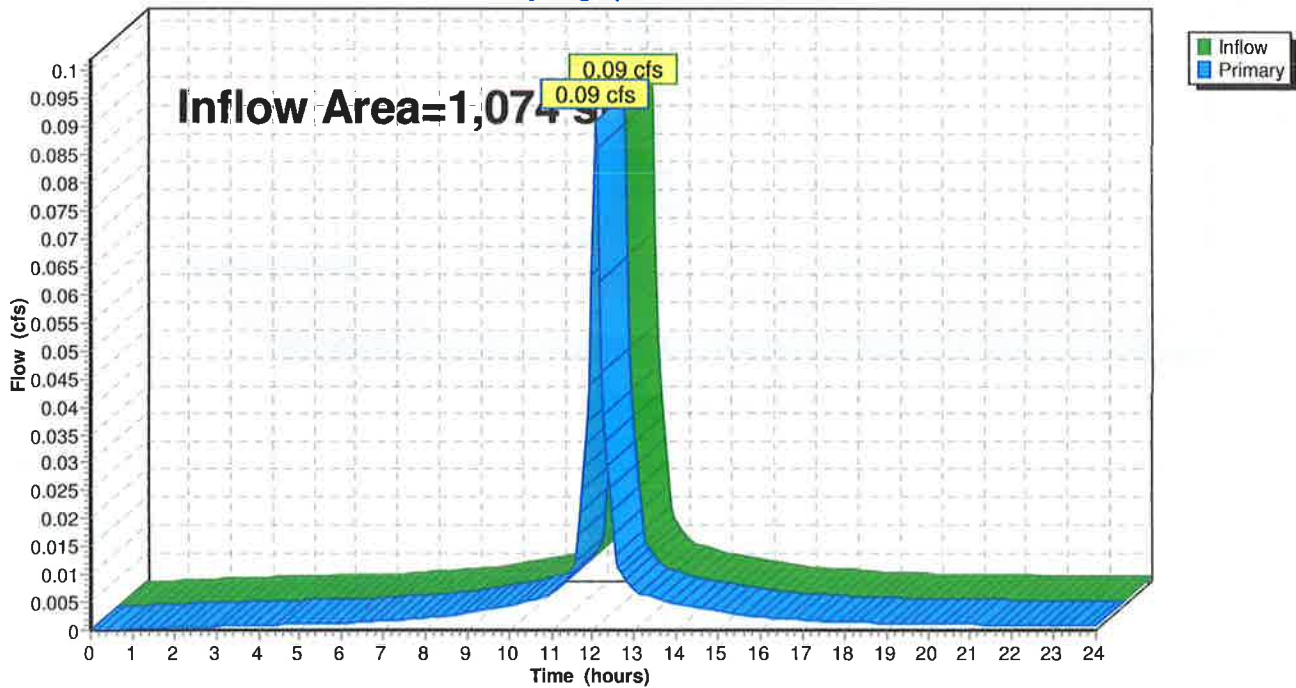



NOAA Atlas 14, Volume 10, Version 3
 Location name: Weston, Connecticut, USA*
 Latitude: 41.2149°, Longitude: -73.3821°
 Elevation: 310 ft**
 * source: ESRI Maps
 ** source: USGS



POINT PRECIPITATION FREQUENCY ESTIMATES

Sanja Perica, Sandra Pavlovic, Michael St. Laurent, Carl Trypaluk, Dale Uhrh, Orlan Wilhite

NOAA, National Weather Service, Silver Spring, Maryland

[PF_tabular](#) | [PF_graphical](#) | [Maps & aeriels](#)

PF tabular

PDS-based point precipitation frequency estimates with 90% confidence intervals (in inches)										
Duration	Average recurrence interval (years)									
	1	2	5	10	25	50	100	200	500	1000
5-min	0.365 (0.280-0.467)	0.425 (0.326-0.545)	0.523 (0.400-0.672)	0.604 (0.460-0.780)	0.716 (0.528-0.954)	0.801 (0.579-1.08)	0.888 (0.623-1.23)	0.981 (0.658-1.39)	1.11 (0.718-1.62)	1.21 (0.766-1.8)
10-min	0.517 (0.397-0.662)	0.602 (0.462-0.772)	0.741 (0.567-0.953)	0.856 (0.652-1.11)	1.01 (0.748-1.35)	1.14 (0.820-1.54)	1.26 (0.883-1.75)	1.39 (0.933-1.98)	1.57 (1.02-2.29)	1.71 (1.08-2.4)
15-min	0.608 (0.467-0.779)	0.708 (0.543-0.908)	0.871 (0.666-1.12)	1.01 (0.767-1.30)	1.19 (0.880-1.59)	1.34 (0.964-1.81)	1.48 (1.04-2.06)	1.64 (1.10-2.32)	1.85 (1.20-2.70)	2.02 (1.28-2.8)
30-min	0.847 (0.651-1.09)	0.985 (0.756-1.26)	1.21 (0.927-1.56)	1.40 (1.06-1.81)	1.66 (1.22-2.20)	1.86 (1.34-2.50)	2.05 (1.44-2.84)	2.26 (1.52-3.20)	2.53 (1.64-3.69)	2.74 (1.73-4.0)
60-min	1.09 (0.834-1.39)	1.26 (0.969-1.62)	1.55 (1.19-1.99)	1.79 (1.36-2.31)	2.12 (1.56-2.82)	2.38 (1.71-3.20)	2.63 (1.83-3.62)	2.88 (1.94-4.09)	3.21 (2.08-4.68)	3.48 (2.19-5.0)
2-hr	1.39 (1.08-1.78)	1.64 (1.27-2.09)	2.05 (1.58-2.62)	2.38 (1.82-3.06)	2.84 (2.11-3.77)	3.20 (2.32-4.30)	3.56 (2.51-4.92)	3.94 (2.66-5.56)	4.47 (2.91-6.49)	4.88 (3.11-7.0)
3-hr	1.60 (1.24-2.03)	1.90 (1.47-2.41)	2.38 (1.84-3.04)	2.79 (2.14-3.56)	3.34 (2.49-4.42)	3.76 (2.75-5.06)	4.20 (2.98-5.80)	4.68 (3.16-6.58)	5.36 (3.49-7.74)	5.90 (3.76-8.3)
6-hr	2.01 (1.57-2.54)	2.41 (1.88-3.04)	3.05 (2.37-3.86)	3.58 (2.77-4.55)	4.32 (3.24-5.68)	4.87 (3.58-6.52)	5.45 (3.90-7.52)	6.11 (4.14-8.54)	7.07 (4.61-10.2)	7.88 (5.01-11.0)
12-hr	2.48 (1.95-3.11)	2.99 (2.34-3.74)	3.81 (2.98-4.78)	4.49 (3.49-5.67)	5.43 (4.10-7.10)	6.13 (4.54-8.16)	6.88 (4.95-9.45)	7.74 (5.26-10.7)	9.00 (5.90-12.8)	10.1 (6.44-14.0)
24-hr	2.91 (2.30-3.62)	3.54 (2.79-4.40)	4.57 (3.60-5.70)	5.43 (4.24-6.80)	6.60 (5.01-8.60)	7.48 (5.57-9.92)	8.42 (6.11-11.5)	9.54 (6.51-13.2)	11.2 (7.36-15.9)	12.6 (8.11-17.0)
2-day	3.25 (2.59-4.02)	4.03 (3.20-4.98)	5.29 (4.19-6.56)	6.34 (4.99-7.89)	7.78 (5.95-10.1)	8.85 (6.64-11.7)	10.0 (7.34-13.7)	11.4 (7.83-15.7)	13.6 (8.98-19.2)	15.5 (10.0-21.0)
3-day	3.53 (2.82-4.34)	4.38 (3.49-5.39)	5.77 (4.58-7.12)	6.92 (5.47-8.58)	8.51 (6.53-11.0)	9.68 (7.29-12.8)	11.0 (8.06-15.0)	12.5 (8.60-17.1)	15.0 (9.89-21.0)	17.1 (11.0-23.0)
4-day	3.80 (3.04-4.66)	4.70 (3.75-5.76)	6.17 (4.91-7.59)	7.39 (5.85-9.13)	9.06 (6.97-11.7)	10.3 (7.78-13.5)	11.7 (8.58-15.9)	13.3 (9.15-18.1)	15.9 (10.5-22.2)	18.1 (11.7-24.0)
7-day	4.56 (3.67-5.57)	5.55 (4.46-6.78)	7.16 (5.73-8.76)	8.50 (6.76-10.4)	10.3 (7.97-13.2)	11.7 (8.85-15.2)	13.2 (9.70-17.7)	14.9 (10.3-20.2)	17.6 (11.7-24.4)	19.8 (12.8-27.0)
10-day	5.31 (4.29-6.45)	6.35 (5.12-7.72)	8.05 (6.47-9.82)	9.46 (7.55-11.6)	11.4 (8.81-14.5)	12.9 (9.73-16.6)	14.4 (10.6-19.2)	16.2 (11.2-21.8)	18.8 (12.5-26.1)	21.0 (13.6-29.0)
20-day	7.54 (6.12-9.10)	8.70 (7.06-10.5)	10.6 (8.58-12.8)	12.2 (9.79-14.8)	14.4 (11.1-18.0)	16.0 (12.1-20.4)	17.7 (13.0-23.2)	19.5 (13.6-26.1)	22.1 (14.7-30.4)	24.1 (15.7-33.0)
30-day	9.37 (7.64-11.3)	10.6 (8.65-12.8)	12.7 (10.3-15.3)	14.4 (11.6-17.4)	16.7 (13.0-20.8)	18.5 (14.0-23.4)	20.3 (14.8-26.3)	22.2 (15.5-29.5)	24.6 (16.5-33.7)	26.5 (17.3-35.0)
45-day	11.6 (9.50-13.9)	13.0 (10.6-15.5)	15.2 (12.4-18.2)	17.0 (13.8-20.5)	19.5 (15.2-24.2)	21.5 (16.3-27.0)	23.4 (17.1-30.1)	25.3 (17.7-33.5)	27.7 (18.6-37.8)	29.5 (19.3-40.0)
60-day	13.5 (11.1-16.1)	14.9 (12.2-17.8)	17.2 (14.1-20.6)	19.2 (15.6-23.1)	21.8 (17.1-27.0)	23.9 (18.2-29.9)	26.0 (19.0-33.2)	27.9 (19.6-36.8)	30.3 (20.4-41.2)	32.1 (21.0-43.0)

Hydrologic Soil Group—State of Connecticut
(21 Lords Highway, Weston)



Natural Resources
Conservation Service

Web Soil Survey
National Cooperative Soil Survey









MAP LEGEND

Area of Interest (AOI)







 Area of Interest (AOI)

Soils

Soil Rating Polygons





 A
 A/D
 B
 B/D
 C
 C/D
 D
 Not rated or not available

Soil Rating Lines

 A
 A/D
 B
 B/D
 C
 C/D
 D
 Not rated or not available

Soil Rating Points

 A
 A/D
 B
 B/D

 C
 C/D
 D
 Not rated or not available

Water Features

 Streams and Canals

Transportation

 Rails
 Interstate Highways
 US Routes
 Major Roads
 Local Roads

Background

 Aerial Photography

MAP INFORMATION

The soil surveys that comprise your AOI were mapped at 1:12,000.

Warning: Soil Map may not be valid at this scale.

Enlargement of maps beyond the scale of mapping can cause misunderstanding of the detail of mapping and accuracy of soil line placement. The maps do not show the small areas of contrasting soils that could have been shown at a more detailed scale.

Please rely on the bar scale on each map sheet for map measurements.

Source of Map: Natural Resources Conservation Service
 Web Soil Survey URL:
 Coordinate System: Web Mercator (EPSG:3857)

Maps from the Web Soil Survey are based on the Web Mercator projection, which preserves direction and shape but distorts distance and area. A projection that preserves area, such as the Albers equal-area conic projection, should be used if more accurate calculations of distance or area are required.

This product is generated from the USDA-NRCS certified data as of the version date(s) listed below.

Soil Survey Area: State of Connecticut
 Survey Area Data: Version 22, Sep 12, 2022

Soil map units are labeled (as space allows) for map scales 1:50,000 or larger.

Date(s) aerial images were photographed: Oct 21, 2022—Oct 27, 2022

The orthophoto or other base map on which the soil lines were compiled and digitized probably differs from the background imagery displayed on these maps. As a result, some minor shifting of map unit boundaries may be evident.

Hydrologic Soil Group

Map unit symbol	Map unit name	Rating	Acres in AOI	Percent of AOI
3	Ridgebury, Leicester, and Whitman soils, 0 to 8 percent slopes, extremely stony	D	1.7	21.2%
46C	Woodbridge fine sandy loam, 8 to 15 percent slopes, very stony	C/D	0.7	9.0%
62D	Canton and Charlton fine sandy loams, 15 to 35 percent slopes, extremely stony	B	0.9	11.1%
84B	Paxton and Montauk fine sandy loams, 3 to 8 percent slopes	C	1.6	19.7%
306	Udorthents-Urban land complex	B	3.1	38.9%
Totals for Area of Interest			8.1	100.0%

Description

Hydrologic soil groups are based on estimates of runoff potential. Soils are assigned to one of four groups according to the rate of water infiltration when the soils are not protected by vegetation, are thoroughly wet, and receive precipitation from long-duration storms.

The soils in the United States are assigned to four groups (A, B, C, and D) and three dual classes (A/D, B/D, and C/D). The groups are defined as follows:

Group A. Soils having a high infiltration rate (low runoff potential) when thoroughly wet. These consist mainly of deep, well drained to excessively drained sands or gravelly sands. These soils have a high rate of water transmission.

Group B. Soils having a moderate infiltration rate when thoroughly wet. These consist chiefly of moderately deep or deep, moderately well drained or well drained soils that have moderately fine texture to moderately coarse texture. These soils have a moderate rate of water transmission.

Group C. Soils having a slow infiltration rate when thoroughly wet. These consist chiefly of soils having a layer that impedes the downward movement of water or soils of moderately fine texture or fine texture. These soils have a slow rate of water transmission.

Group D. Soils having a very slow infiltration rate (high runoff potential) when thoroughly wet. These consist chiefly of clays that have a high shrink-swell potential, soils that have a high water table, soils that have a claypan or clay layer at or near the surface, and soils that are shallow over nearly impervious material. These soils have a very slow rate of water transmission.

If a soil is assigned to a dual hydrologic group (A/D, B/D, or C/D), the first letter is for drained areas and the second is for undrained areas. Only the soils that in their natural condition are in group D are assigned to dual classes.

Rating Options

Aggregation Method: Dominant Condition

Component Percent Cutoff: None Specified

Tie-break Rule: Higher

OTTO R. THEALL
PROFESSIONAL SOIL SCIENTIST / WETLAND SCIENTIST
2 LLOYD ROAD
NORWALK, CONNECTICUT 06850
OFFICE (203) 845-0278
MOBILE (203) 247-0650

SOIL INVESTIGATION REPORT
21 LORDS HIGHWAY
WESTON, CONNECTICUT
MARCH 17, 2023
JOB # 4623

I completed an on-site investigation of the soil types on the residential property that is located at 21 Lords Highway in Weston, Connecticut on March 17, 2023. The examination for wetland soils was conducted by inspection of approximately 100 soil samples taken with spade and auger.

The definitions of wetlands and watercourses used in this investigation are as follows. Inland wetlands in Connecticut, according to the Connecticut General Statutes, are lands, including submerged lands, which consist of any of the soil types designated as poorly drained, very poorly drained, alluvial, and floodplain by the NRCS. Watercourses include rivers, streams, brooks, waterways, lakes, ponds, marshes, swamps, bogs and all other bodies of water, natural or artificial, vernal or intermittent. Intermittent watercourses are to be delineated by a defined permanent channel and bank and the occurrence of two or more of the following characteristics: (A) evidence of scour or deposits of recent alluvium or detritus, (B) the presence of standing or flowing water for a duration longer than a particular storm incident, and (C) the presence of hydrophytic vegetation.

The wetland soils consist of Ridgebury, Leicester and Whitman soils, extremely stony (3). The non-wetland soils consist of Woodbridge fine sandy loam, very stony (46), Canton and Charlton soils, extremely stony (62), Paxton and Montauk fine sandy loams (84) and Udorthents-Urban land complex (306). The soil map units contain inclusions of other soil types. **The results of this investigation are subject to change until they are accepted by Weston Conservation Commission.**

Respectfully submitted:



Otto R. Theall

TABACCO ROAD

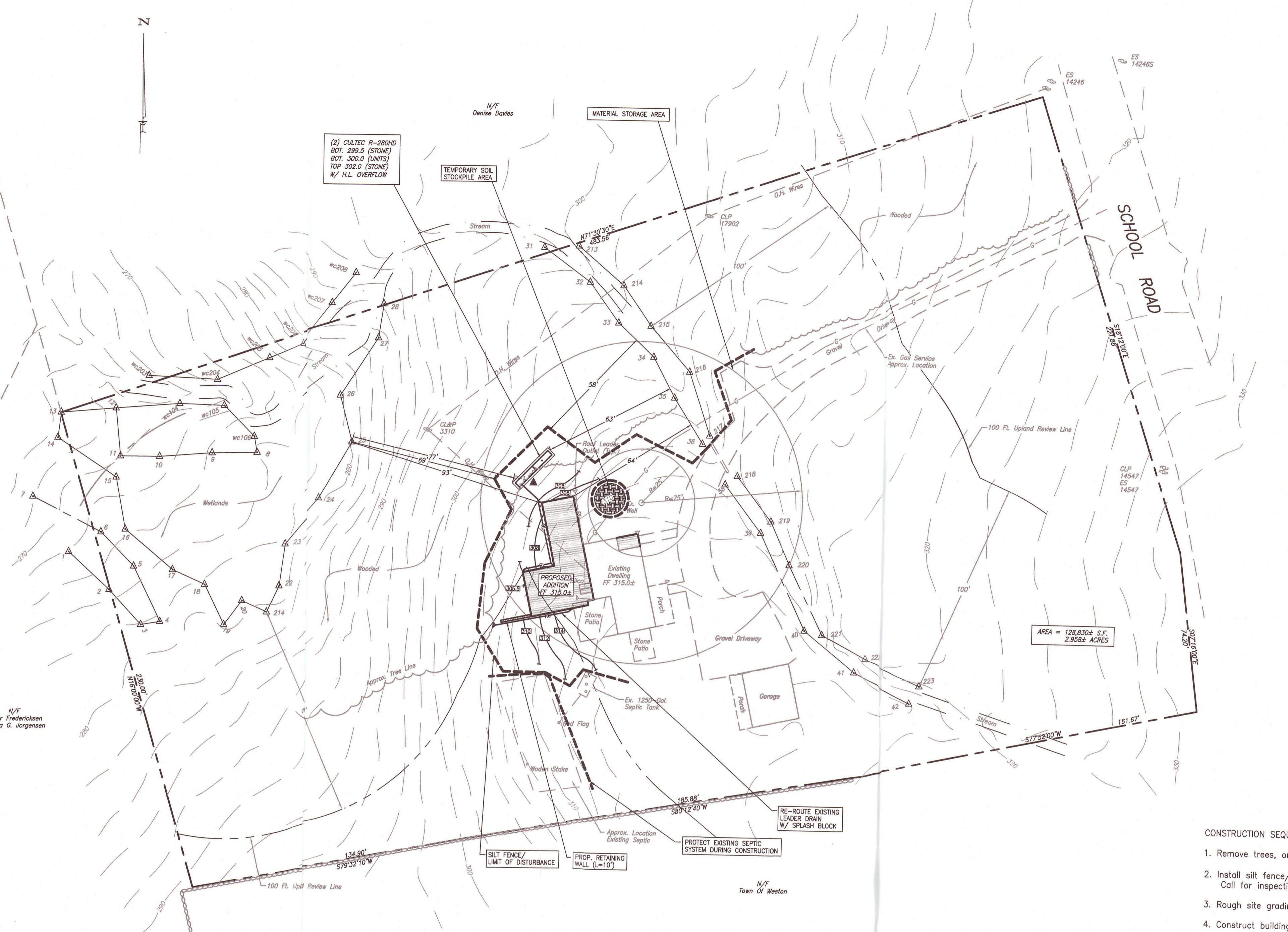
SCHOOL ROAD

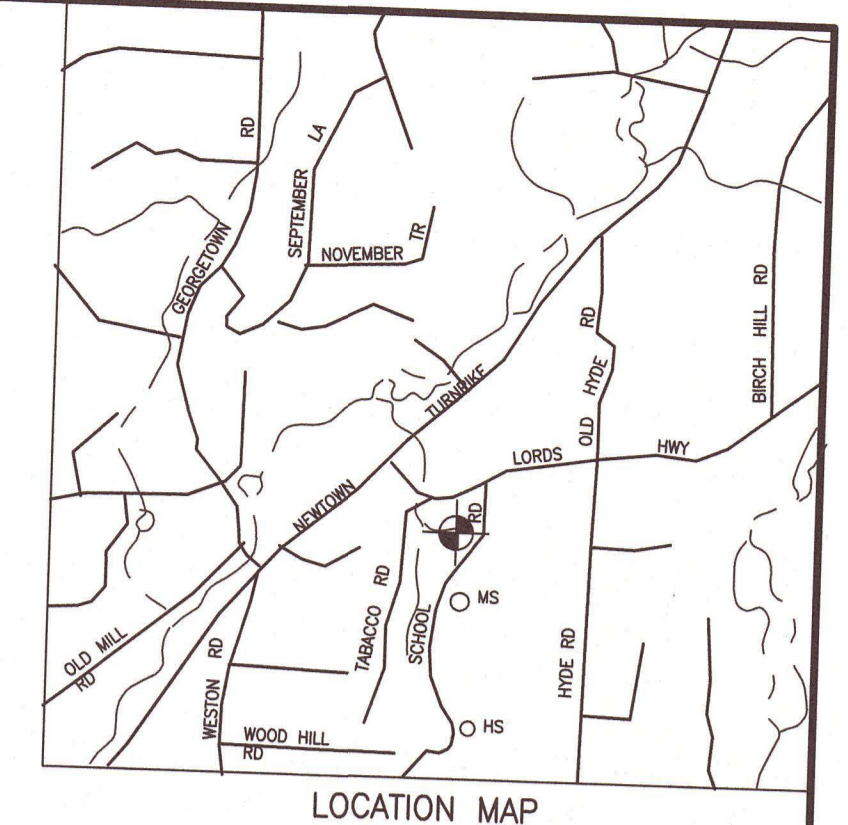

PERCOLATION TEST DATA - 7-31-23
DEPTH - 18"
PRE-SOAK @ 1:00
REFILL @ 1:33
1:33 7.5"
1:43 10.5"
1:53 12.5"
2:03 14.25"
2:13 16.0"
2:23 DRY
PERCOLATION RATE: 1"/5.7 MINUTES



- GENERAL CONSTRUCTION NOTES:
- CONSTRUCTION AND STRUCTURES SHALL COMPLY WITH ALL MUNICIPAL OR STATE REQUIREMENTS. ALL WORK SHALL BE CERTIFIED BY A REGISTERED PROFESSIONAL ENGINEER, TO THE SATISFACTION OF THE ENGINEERING BUREAU, THAT CONSTRUCTION IS IN ACCORDANCE WITH THESE PLANS.
 - THE ENGINEERING BUREAU OF THE DEPARTMENT OF PUBLIC WORKS AND THE ENGINEER OF RECORD SHALL BE NOTIFIED THREE DAYS PRIOR TO THE COMMENCEMENT OF EACH PHASE OF CONSTRUCTION.
 - NO CERTIFICATE OF CONFORMANCE TO STANDARDS SHALL BE ISSUED BY THE DESIGN ENGINEER IF PROPER NOTICE IS NOT PROVIDED FOR INSPECTIONS OR IF INSPECTIONS ARE NOT MADE PRIOR TO BACKFILLING OF BELOW GROUND STRUCTURES AND APPURTENANCES.
 - SUBSURFACE STRUCTURES AND UTILITIES HAVE BEEN DETERMINED FROM EXISTING RECORDS AND ARE NOT GUARANTEED TO BE COMPLETE OR ACCURATE. IN ORDER TO AVOID CONFLICT OF THE PROPOSED WORK AND EXISTING UTILITIES, THE CONTRACTOR SHALL LOCATE EXISTING UTILITIES BY EXCAVATING TEST HOLES. IF THE CONTRACTOR DETERMINES THAT A CONFLICT EXISTS, HE SHALL IMMEDIATELY NOTIFY THE ENGINEER, WHO WILL MAKE THE NECESSARY ADJUSTMENTS.
 - EXISTING SITE INFORMATION WAS TAKEN FROM A 'ZONING LOCATION SURVEY PREPARED FOR LISA PASSAVANT, 21 LORDS HIGHWAY, WESTON, CT' BY BRAUTIGAM LAND SURVEYORS, LLC, DATED 3-17-23, REV. 4-27-23.
 - ALL HIGH-DENSITY POLYETHYLENE (H.D.P.E.) STORM DRAIN PIPE SHALL BE 'SMOOTH INTERIOR' TYPE AND MEET THE REQUIREMENTS OF ASTM F405 & F667 AND AASHTO M252 & M294.
 - THE CONTRACTOR SHALL NOTIFY "CALL BEFORE YOU DIG" AT 1-800-922-4455, PRIOR TO START OF CONSTRUCTION.
 - TOTAL SITE AREA = 128,830± S.F. ~ 2.958± AC.
 - THE PROPERTY IS SERVED BY PRIVATE WELL AND ON-SITE SEWAGE DISPOSAL SYSTEM.
 - PROPERTY SHOWN IN ASSESSORS OFFICE AS MAP-BLOCK-LOT: 20-1-7.
 - LOCATIONS OF CRITICAL UTILITIES SHALL BE VERIFIED IN THE FIELD, BY THE CONTRACTOR, AT THE START OF CONSTRUCTION.
 - VERTICAL DATUM= N.A.V.D. 88 (TOWN OF WESTON GIS MAPPING). (CONTOURS SHOWN AT 2 FOOT INTERVALS)

- CONSTRUCTION SEQUENCE
- Remove trees, only as shown on plan.
 - Install silt fence/hay boles/silt fence per site plan. Call for inspection by conservation officer.
 - Rough site grading as needed. Construct retaining wall.
 - Construct building foundation.
 - Construct building addition. Install drainage system. Finish site work.
 - Fine grade, topsoil and seed disturbed areas.
 - Wait until slopes are stabilized before removing silt fences. (one growing season). Removal to be approved by project engineer or Weston Conservation officer.

- SEDIMENTATION AND EROSION CONTROL NOTES
- LAND DISTURBANCE SHALL BE KEPT TO A MINIMUM. PERMANENT STABILIZATION SHALL BE SCHEDULED AS SOON AS FINAL GRADES ARE ESTABLISHED.
 - ALL DISTURBED AREAS SHALL BE FINE GRADED AND SEEDED WITH AN APPROVED SEED MIXTURE. COVER NEWLY SEEDED AREAS WITH MULCH HAY OR SALT HAY.
 - ALL EROSION AND SEDIMENT CONTROL MEASURES SHALL BE CONSTRUCTED IN ACCORDANCE WITH THE STANDARDS AND SPECIFICATIONS OF THE 2002 CONNECTICUT 'GUIDELINES FOR SOIL EROSION AND SEDIMENT CONTROL' HANDBOOK.
 - ALL CONTROL MEASURES SHALL BE MAINTAINED IN EFFECTIVE CONDITION THROUGHOUT THE CONSTRUCTION PERIOD. CHECK AFTER EACH STORM EVENT.
 - ADDITIONAL CONTROL MEASURES SHALL BE INSTALLED DURING THE CONSTRUCTION PERIOD, IF REQUIRED BY TOWN AUTHORITIES.
 - SEDIMENT DEPOSITS REMOVED FROM FILTER BARRIERS SHALL BE PLACED IN FILL AREAS OR SPREAD WHERE THERE IS PROPOSED VEGETATIVE COVER. ANY SEDIMENT DEPOSITS REMAINING AFTER THE FILTER BARRIER IS REMOVED SHALL BE FINE GRADED AND PLANTED ACCORDING TO PLAN.
 - THE OWNER IS ASSIGNED THE RESPONSIBILITY FOR IMPLEMENTING THIS EROSION AND SEDIMENT CONTROL PLAN. THIS RESPONSIBILITY INCLUDES THE INSTALLATION AND MAINTENANCE OF CONTROL MEASURES, INFORMING ALL PARTIES ENGAGED ON THE CONSTRUCTION SITE OF THE REQUIREMENTS AND OBJECTIVES OF THE PLAN, NOTIFYING THE PLANNING AND ZONING OFFICE (AND/OR THE CONSERVATION COMMISSION) OF ANY TRANSFER OF THIS RESPONSIBILITY AND CONVEYING A COPY OF THE EROSION AND SEDIMENT CONTROL PLAN IF THE TITLE TO THE LAND IS TRANSFERRED TO A NEW OWNER.

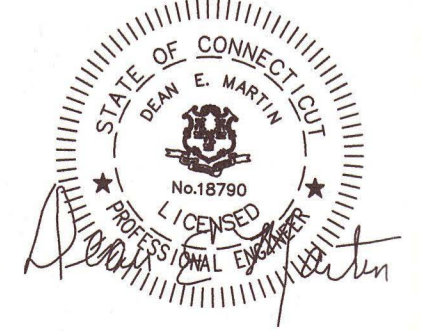
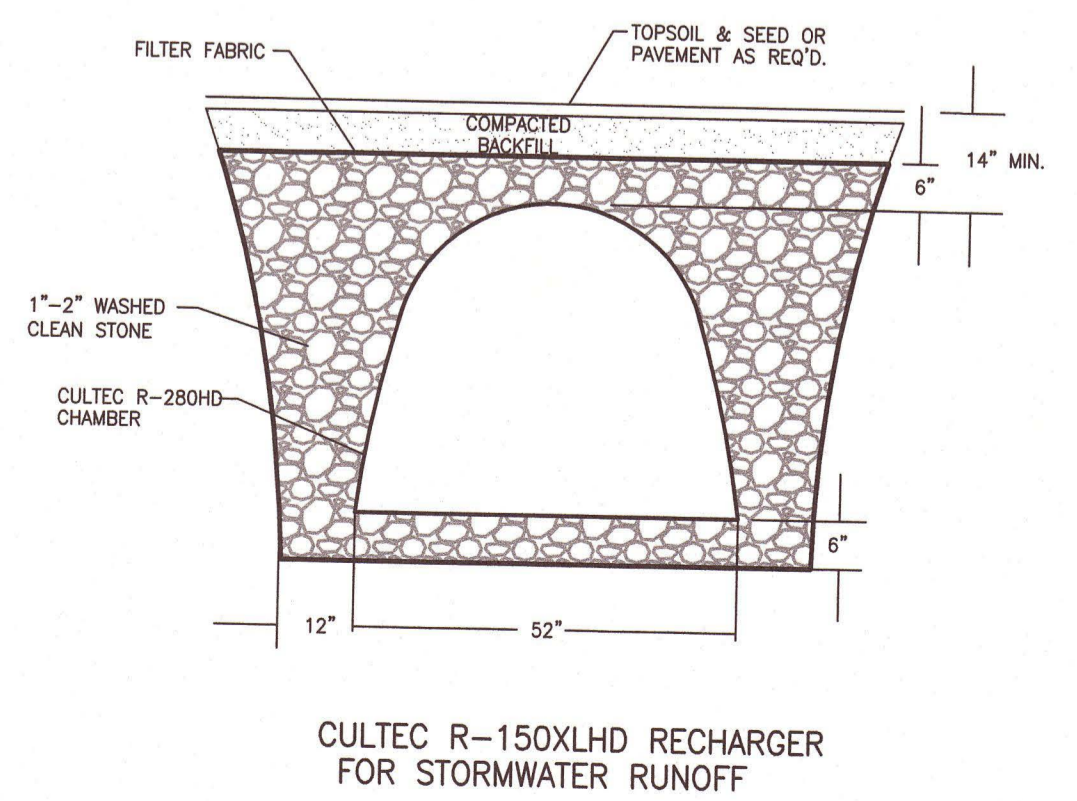
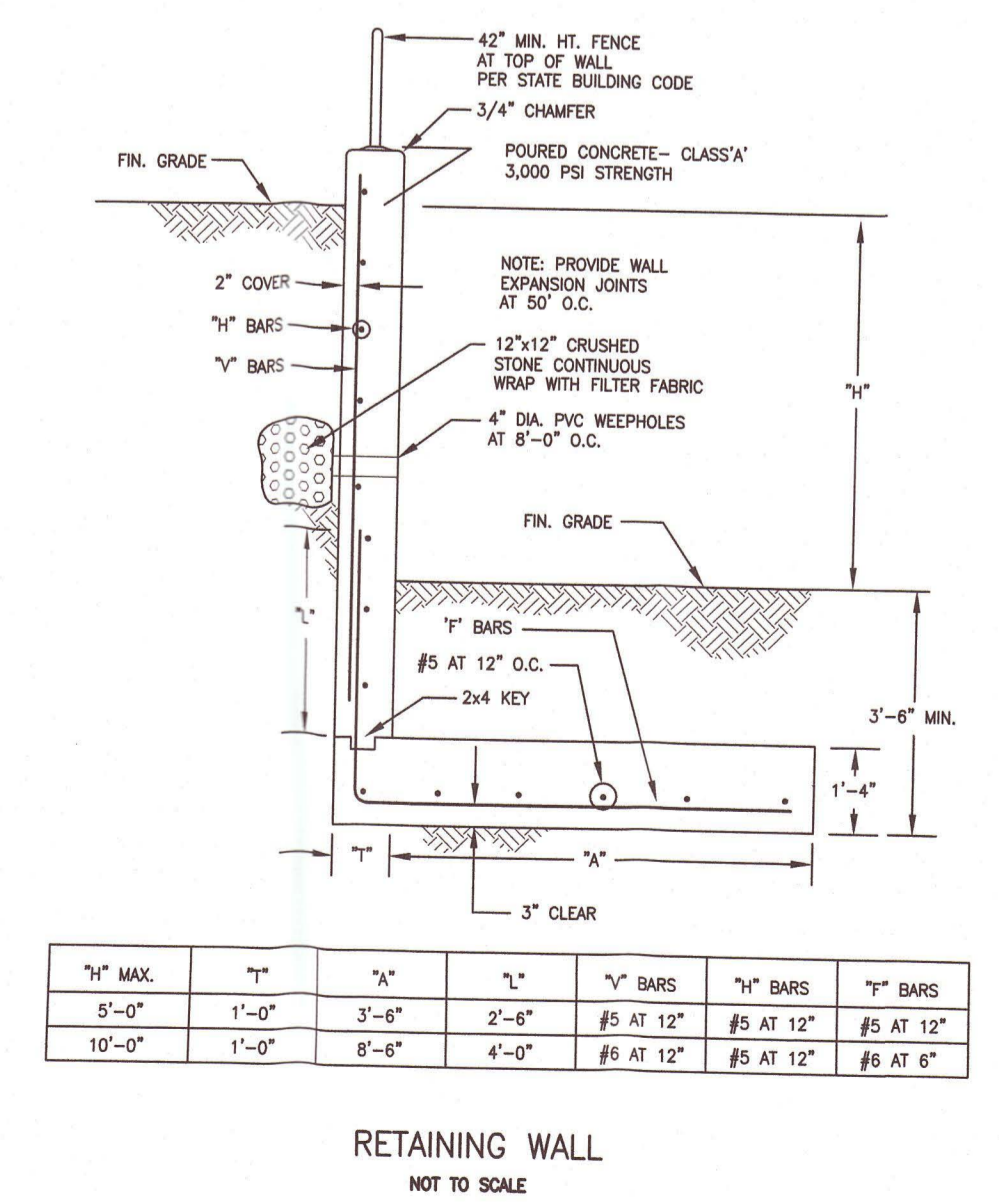
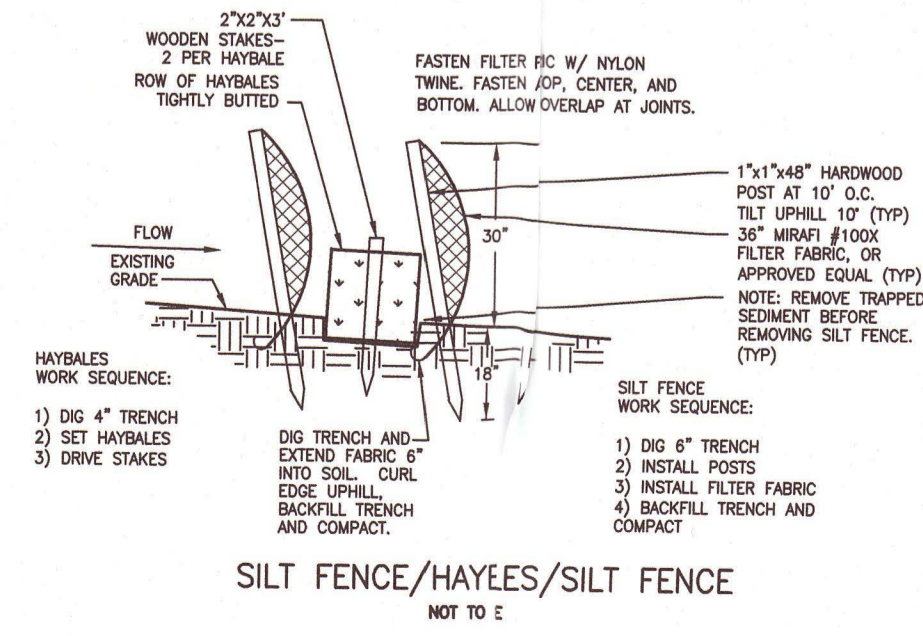
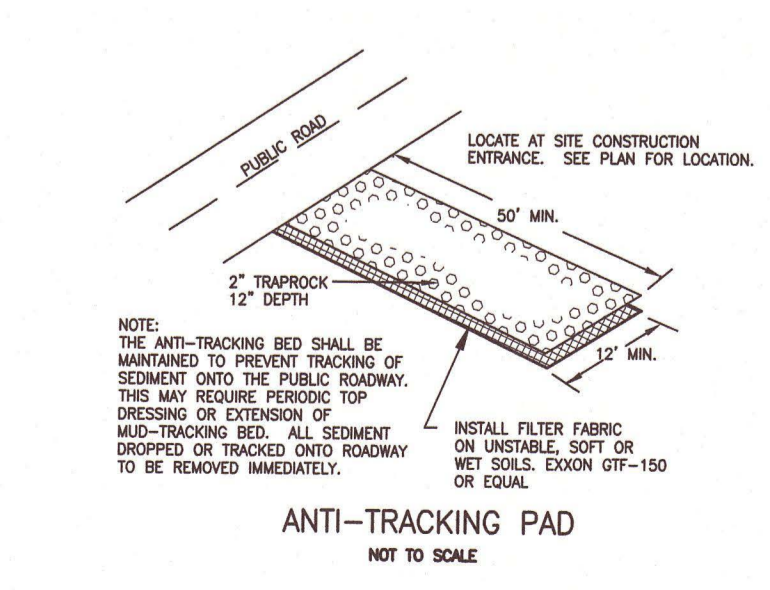
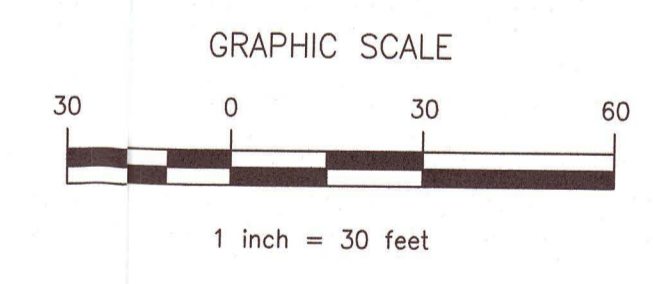
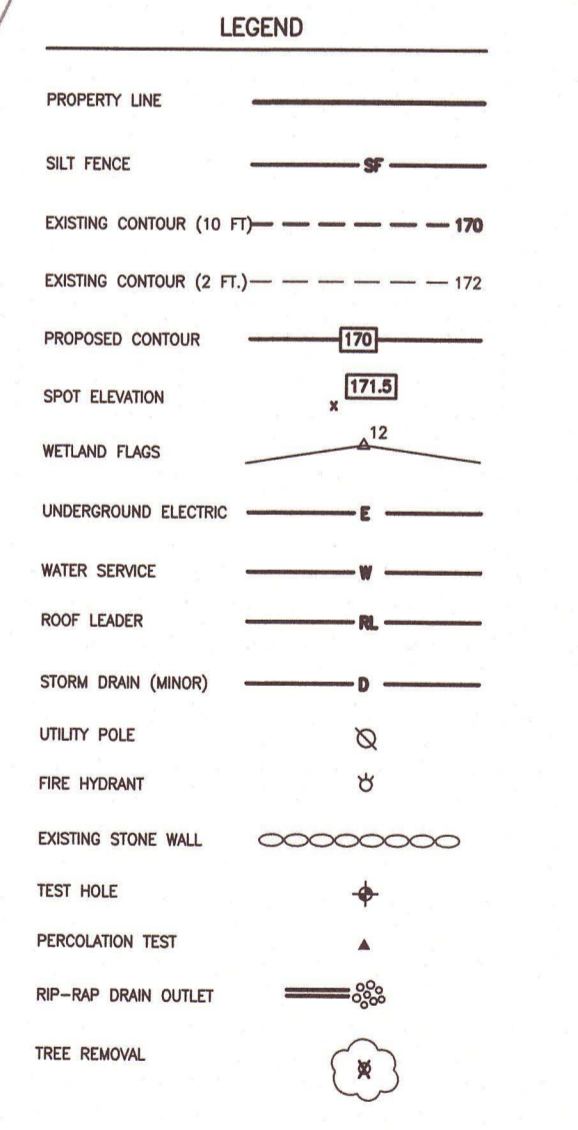

RECEIVED
AUG 07 2023
LISA PASSAVANT, REGISTERED PROFESSIONAL ENGINEER
21 LORDS HIGHWAY, WESTON, CONNECTICUT
PROJECT: 23-5642
1 OF 1 sheet
8-2-23 date
GRUMMAN ENGINEERING L.L.C.
CONSULTING CIVIL ENGINEERS
20 KNIGHT STREET, NORWALK, CONNECTICUT 06851
PH: (203) 853-3833 FAX: (203) 286-5057
230802 SITE

PERCOLATION TEST DATA - 7-31-23

DEPTH - 18"
PRE-SOAK @ 1:00

REFILL @ 1:33

1:33 7.5"
1:43 10.5"
1:53 12.5"
2:03 14.25"
2:13 16.0"
2:23 DRY

PERCOLATION RATE: 1"/5.7 MINUTES

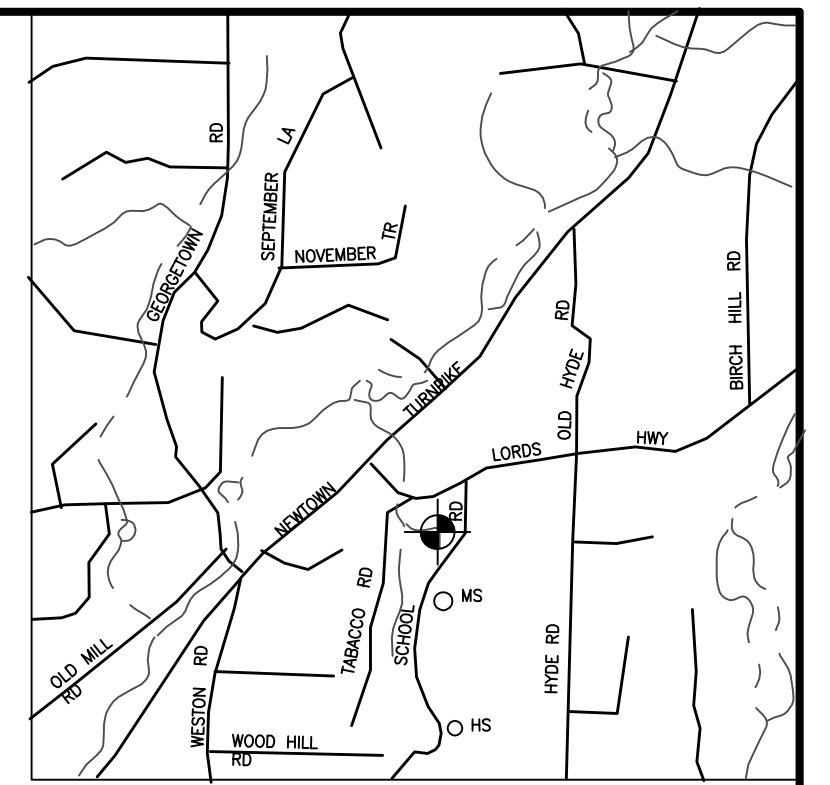

LOCATION MAP

GENERAL CONSTRUCTION NOTES:

- CONSTRUCTION AND STRUCTURES SHALL COMPLY WITH ALL MUNICIPAL OR STATE REQUIREMENTS. ALL WORK SHALL BE CERTIFIED BY A REGISTERED PROFESSIONAL ENGINEER, TO THE SATISFACTION OF THE ENGINEERING BUREAU, THAT CONSTRUCTION IS IN ACCORDANCE WITH THESE PLANS.
- THE ENGINEERING BUREAU OF THE DEPARTMENT OF PUBLIC WORKS AND THE ENGINEER OF RECORD SHALL BE NOTIFIED THREE DAYS PRIOR TO THE COMMENCEMENT OF EACH PHASE OF CONSTRUCTION.
- NO CERTIFICATE OF CONFORMANCE TO STANDARDS SHALL BE ISSUED BY THE DESIGN ENGINEER IF PROPER NOTICE IS NOT PROVIDED FOR INSPECTIONS OR IF INSPECTIONS ARE NOT MADE PRIOR TO BACKFILLING OF BELOW GROUND STRUCTURES AND APPURTENANCES.
- SUBSURFACE STRUCTURES AND UTILITIES HAVE BEEN DETERMINED FROM EXISTING RECORDS AND ARE NOT GUARANTEED TO BE COMPLETE OR ACCURATE. IN ORDER TO AVOID CONFLICT OF THE PROPOSED WORK AND EXISTING UTILITIES, THE CONTRACTOR SHALL LOCATE EXISTING UTILITIES BY EXCAVATING TEST HOLES. IF THE CONTRACTOR DETERMINES THAT A CONFLICT EXISTS, HE SHALL IMMEDIATELY NOTIFY THE ENGINEER, WHO WILL MAKE THE NECESSARY ADJUSTMENTS.
- EXISTING SITE INFORMATION WAS TAKEN FROM A 'ZONING LOCATION SURVEY PREPARED FOR LISA PASSAVANT, 21 LORDS HIGHWAY, WESTON, CT' BY BRAUTIGAM LAND SURVEYORS, LLC, DATED 3-17-23, REV. 4-27-23.
- ALL HIGH-DENSITY POLYETHYLENE (H.D.P.E.) STORM DRAIN PIPE SHALL BE 'SMOOTH INTERIOR' TYPE AND MEET THE REQUIREMENTS OF ASTM F405 & F667 AND AASHTO M252 & M294.
- THE CONTRACTOR SHALL NOTIFY 'CALL BEFORE YOU DIG' AT 1-800-922-4455, PRIOR TO START OF CONSTRUCTION.
- TOTAL SITE AREA = 128,830± S.F. ~ 2.958± AC.
- THE PROPERTY IS SERVED BY PRIVATE WELL AND ON-SITE SEWAGE DISPOSAL SYSTEM.
- PROPERTY SHOWN IN ASSESSORS OFFICE AS MAP-BLOCK-LOT: 20-1-7.
- LOCATIONS OF CRITICAL UTILITIES SHALL BE VERIFIED IN THE FIELD, BY THE CONTRACTOR, AT THE START OF CONSTRUCTION.
- VERTICAL DATUM= N.A.V.D. 88 (TOWN OF WESTON GIS MAPPING). (CONTOURS SHOWN AT 2 FOOT INTERVALS)

CONSTRUCTION SEQUENCE

- Remove trees, only as shown on plan.
- Install silt fence/hay bales/silt fence per site plan. Call for inspection by conservation officer.
- Rough site grading as needed. Construct retaining wall.
- Construct building foundation.
- Construct building addition. Install drainage system. Finish site work.
- Fine grade, topsoil and seed disturbed areas.
- Wait until slopes are stabilized before removing silt fences. (one growing season). Removal to be approved by project engineer or Weston Conservation officer.

SEDIMENTATION AND EROSION CONTROL NOTES

- LAND DISTURBANCE SHALL BE KEPT TO A MINIMUM. PERMANENT STABILIZATION SHALL BE SCHEDULED AS SOON AS FINAL GRADES ARE ESTABLISHED.
- ALL DISTURBED AREAS SHALL BE FINE GRADED AND SEEDED WITH AN APPROVED SEED MIXTURE. COVER NEWLY SEEDED AREAS WITH MULCH HAY OR SALT HAY.
- ALL EROSION AND SEDIMENT CONTROL MEASURES SHALL BE CONSTRUCTED IN ACCORDANCE WITH THE STANDARDS AND SPECIFICATIONS OF THE 2002 CONNECTICUT 'GUIDELINES FOR SOIL EROSION AND SEDIMENT CONTROL' HANDBOOK.
- ALL CONTROL MEASURES SHALL BE MAINTAINED IN EFFECTIVE CONDITION THROUGHOUT THE CONSTRUCTION PERIOD. CHECK AFTER EACH STORM EVENT.
- ADDITIONAL CONTROL MEASURES SHALL BE INSTALLED DURING THE CONSTRUCTION PERIOD, IF REQUIRED BY TOWN AUTHORITIES.
- SEDIMENT DEPOSITS REMOVED FROM FILTER BARRIERS SHALL BE PLACED IN FILL AREAS OR SPREAD WHERE THERE IS PROPOSED VEGETATIVE COVER. ANY SEDIMENT DEPOSITS REMAINING AFTER THE FILTER BARRIER IS REMOVED SHALL BE FINE GRADED AND PLANTED ACCORDING TO PLAN.
- THE OWNER IS ASSIGNED THE RESPONSIBILITY FOR IMPLEMENTING THIS EROSION AND SEDIMENT CONTROL PLAN. THIS RESPONSIBILITY INCLUDES THE INSTALLATION AND MAINTENANCE OF CONTROL MEASURES, INFORMING ALL PARTIES ENGAGED ON THE CONSTRUCTION SITE OF THE REQUIREMENTS AND OBJECTIVES OF THE PLAN, NOTIFYING THE PLANNING AND ZONING OFFICE (AND/OR THE CONSERVATION COMMISSION) OF ANY TRANSFER OF THIS RESPONSIBILITY AND CONVEYING A COPY OF THE EROSION AND SEDIMENT CONTROL PLAN IF THE TITLE TO THE LAND IS TRANSFERRED TO A NEW OWNER.



LEGEND

- PROPERTY LINE
- SILT FENCE
- EXISTING CONTOUR (10 FT)
- EXISTING CONTOUR (2 FT)
- PROPOSED CONTOUR
- SPOT ELEVATION
- WETLAND FLAGS
- UNDERGROUND ELECTRIC
- WATER SERVICE
- ROOF LEADER
- STORM DRAIN (MINOR)
- UTILITY POLE
- FIRE HYDRANT
- EXISTING STONE WALL
- TEST HOLE
- PERCOLATION TEST
- RR-RAP DRAIN OUTLET
- TREE REMOVAL

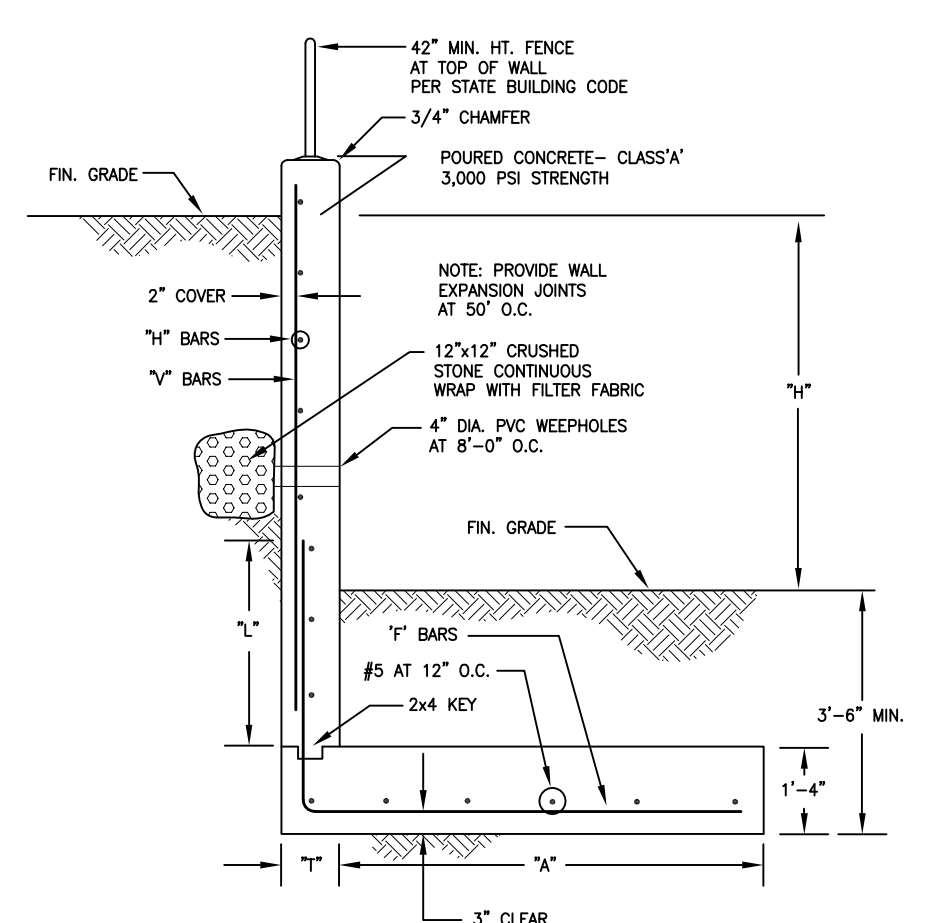
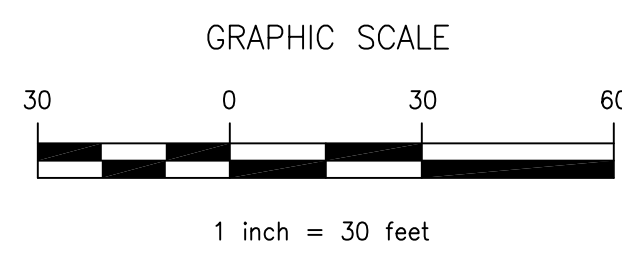

7\"/>						
5'-0"	1'-0"	3'-6"	2'-6"	#5 AT 12"	#5 AT 12"	#5 AT 12"
10'-0"	1'-0"	8'-6"	4'-0"	#6 AT 12"	#5 AT 12"	#6 AT 6"

RETAINING WALL
NOT TO SCALE

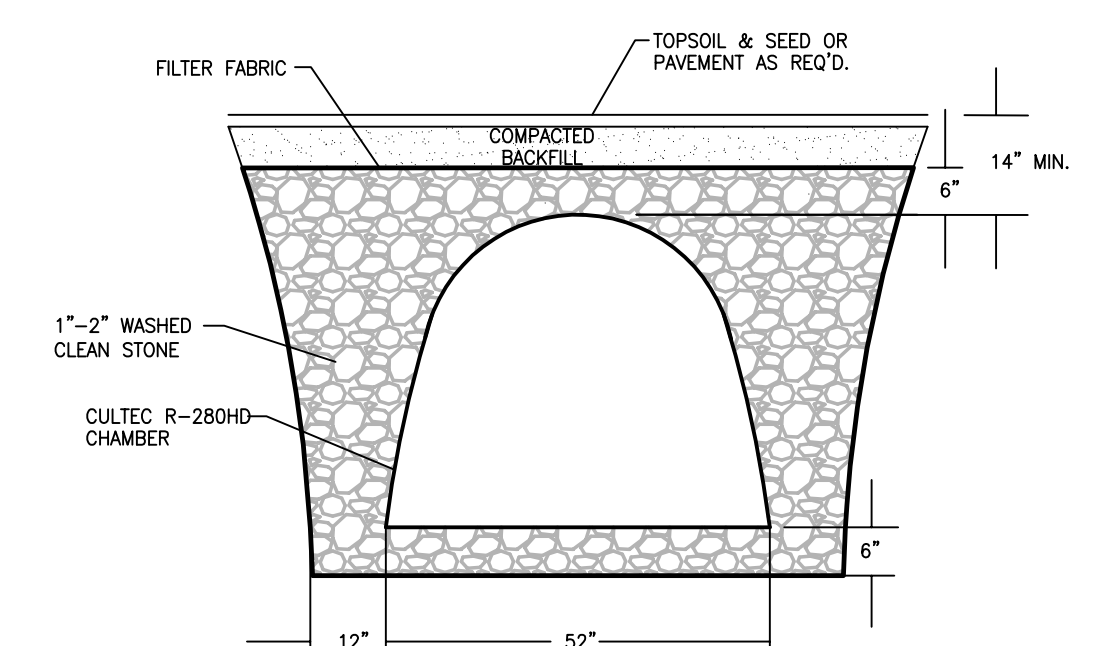

CULTEC R-150XLHD RECHARGER
FOR STORMWATER RUNOFF

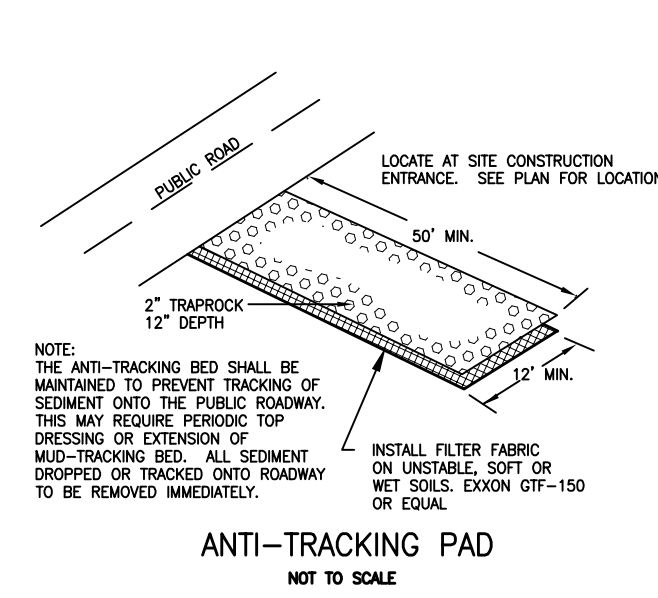

ANTI-TRACKING PAD
NOT TO SCALE

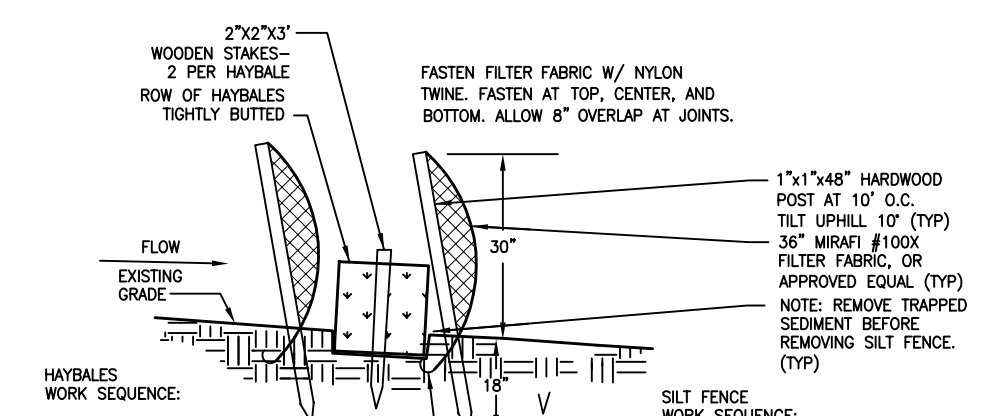

SILT FENCE/HAYBALES/SILT FENCE
NOT TO SCALE

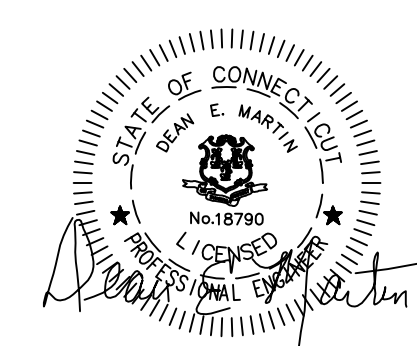

REVISED: 9-20-23- WELL PROTECTION, ANTI-TRACK PAD, STOCKPILE

<p>LISA PASSAVANT 21 LORDS HIGHWAY WESTON, CONNECTICUT</p>		<p>23-5642 project</p>
<p>SITE IMPROVEMENT PLAN</p>		<p>1 OF 1 sheet</p>
<p>GRUMMAN ENGINEERING L.L.C. CONSULTING CIVIL ENGINEERS 20 KNIGHT STREET, NORWALK, CONNECTICUT 06851 PH: (203) 853-3833 FAX: (203) 286-5057</p>		<p>8-2-23 date</p>